

# Air or Electric Tool Positioners

## Illustrated Parts List and Assembly Guide

### Models WS50-EC, WS50-AM, WSP-EC, WSP-AM

Item	Description	Qty	Part No.
1	Post & Base Kit–WSP-EC & WSP-AM only (Kit includes base, post, two set screws, two nylon bushings and two collars)	1	620557
2	Front Mount–WS50-EC & WS50-AM only (Includes hardware for mounting to column)	1	620284
3	Adapter Bushing–WS50-EC & WS50-AM only	1	620558
4	Cast Arm	1	62055401
5	Electric Tool Holder Kit–WSP-EC & WS50-EC only (Kit includes tool holder assembly, two snap clamps, two nylon bushings and shoulder bolt)	1	620555
6	Air Tool Holder Kit–WSP-AM & WS50-AM only (Kit includes tool holder assembly, two nylon bushings and shoulder bolt)	1	620556

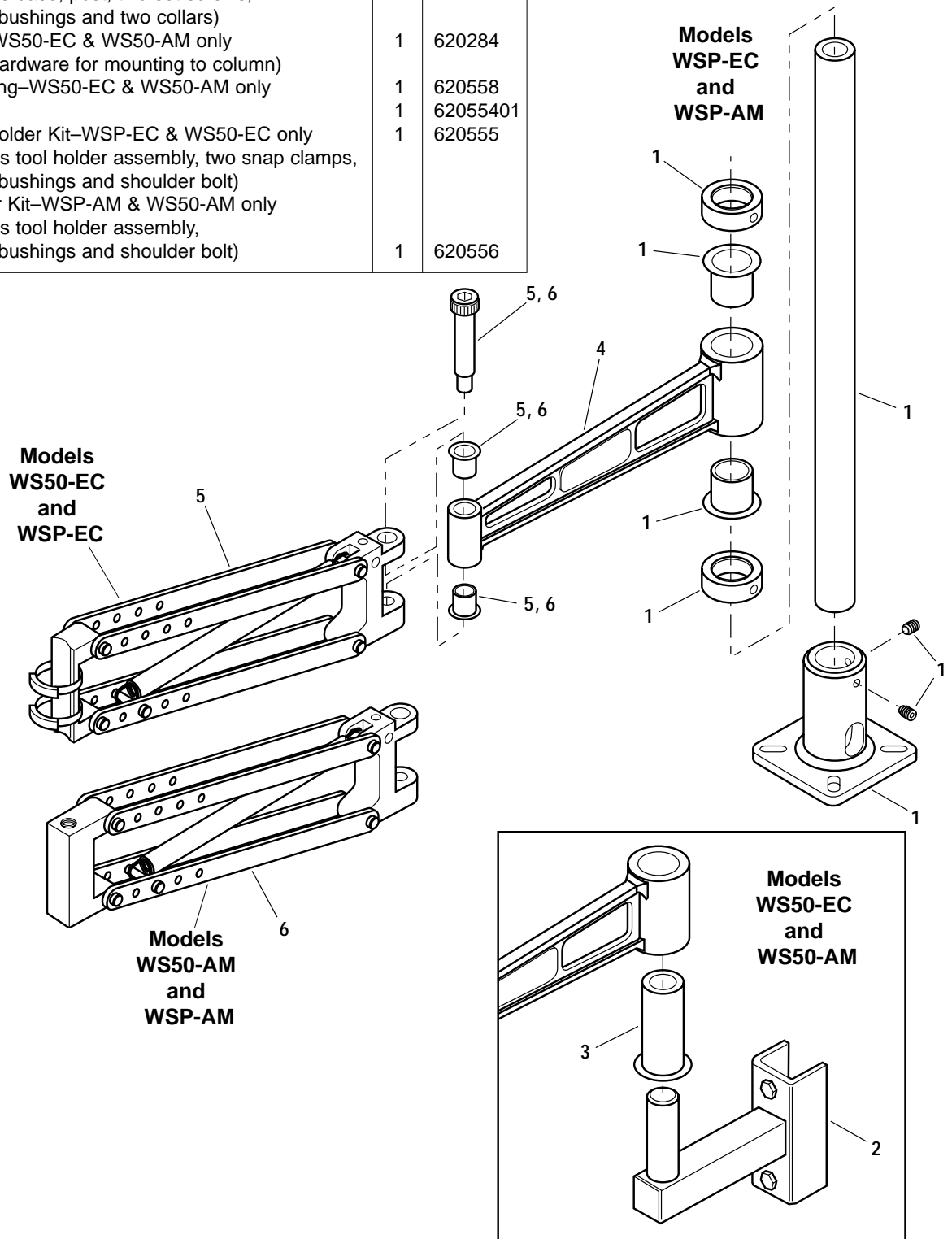

**Workplace Solutions**

P.O. Box 26 • 600 South Clark St.  
 Mayville, WI 53050  
 Phone: 920-387-4120  
 Fax: 920-387-4189