

## Assembly Instructions 4500S Inspection Stand

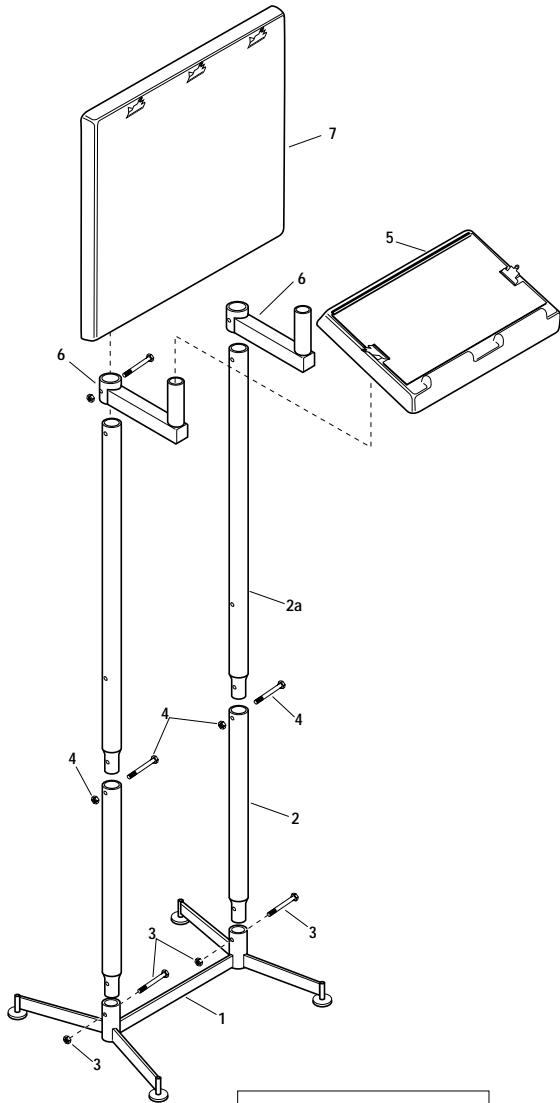

**NOTE:** This stand may be assembled with writing surface (item 5) at a height suitable for either standing use or seated use. To assemble for seated use, substitute 11" long post section for 22 1/2" long section (item 2).

Refer to illustration at left. *NOTE: The unit you are assembling may look slightly different than the illustration.*

1. Identify posts for stand (two each—items 2 & 2a). Lower posts (item 2) are shorter.
2. Snap glides into base (1).
3. Slide end of lower posts (2) into base (1). Secure with screws and nuts (3). Tighten. Slide upper posts into top of lower posts. Secure with screws and nuts (4). Tighten.
4. Slide panel mounting brackets (6) onto stand posts. Secure with screws and nuts through holes located near bottom of posts. Tighten.
5. Slide mounting sleeves on back of display panel (7) onto tops of stand posts. Secure with screws and nuts (See detail 1.). Tighten.
6. Slide sleeves on writing panel assembly (5) onto top of mounting brackets. Secure with screws and nuts (See detail 1.). Tighten.
7. Remove protective sheets from clear acrylic covers by running knife blade along edge of hinge and stripping off tinted plastic film.

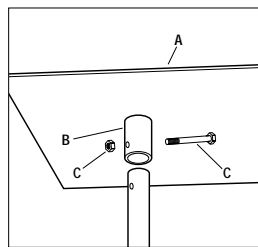

-Detail 1-  
Assembling panels  
to posts and  
mounting brackets.



**Workplace Solutions**

P.O. Box 26 • 600 South Clark St.  
Mayville, WI 53050  
Phone: 920-387-4120  
Fax: 920-387-4189