

## Assembly Instructions 4000S Document Stand

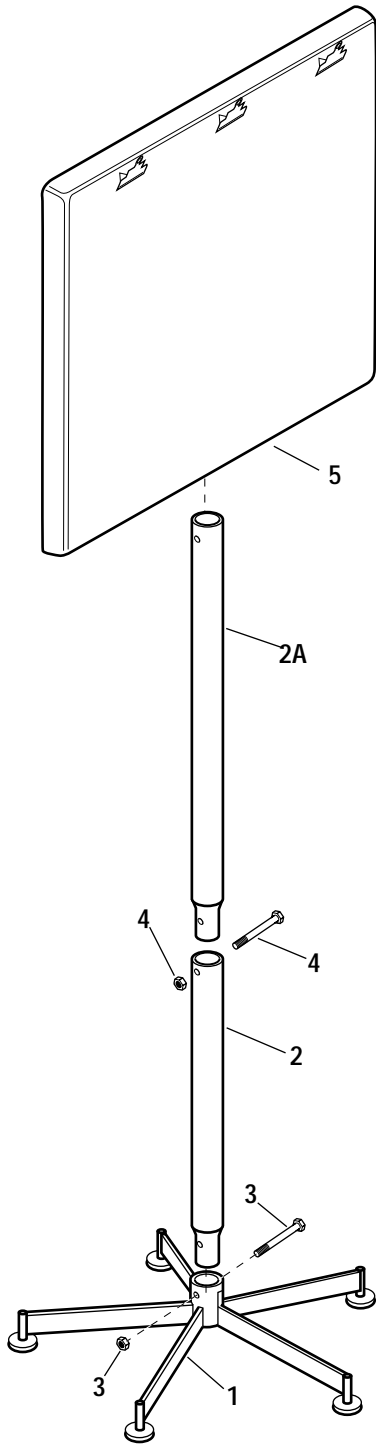

**NOTE:** This stand may be assembled with writing surface (item 5) at a height suitable for either standing use or seated use. To assemble for seated use, substitute 11" long post section for 22 1/2" long section (item 2).

Refer to illustration at left. *NOTE: The unit you are assembling may look slightly different than the illustration.*

1. Identify posts for stand (item 2 and 2A). 2A is longer.
2. Slide end of lower post (2) into base (1). Secure with screw and nut (3). Tighten. Slide upper post into top of lower post. Secure with screw and nut (4). Tighten.
3. Slide sleeve on back of display panel onto top of stand post. Secure with screw and nut. Tighten.



**Workplace Solutions**

P.O. Box 26 • 600 South Clark St.  
Mayville, WI 53050  
Phone: 920-387-4120  
Fax: 920-387-4189