

Assembly Instructions 1210S Information Stand

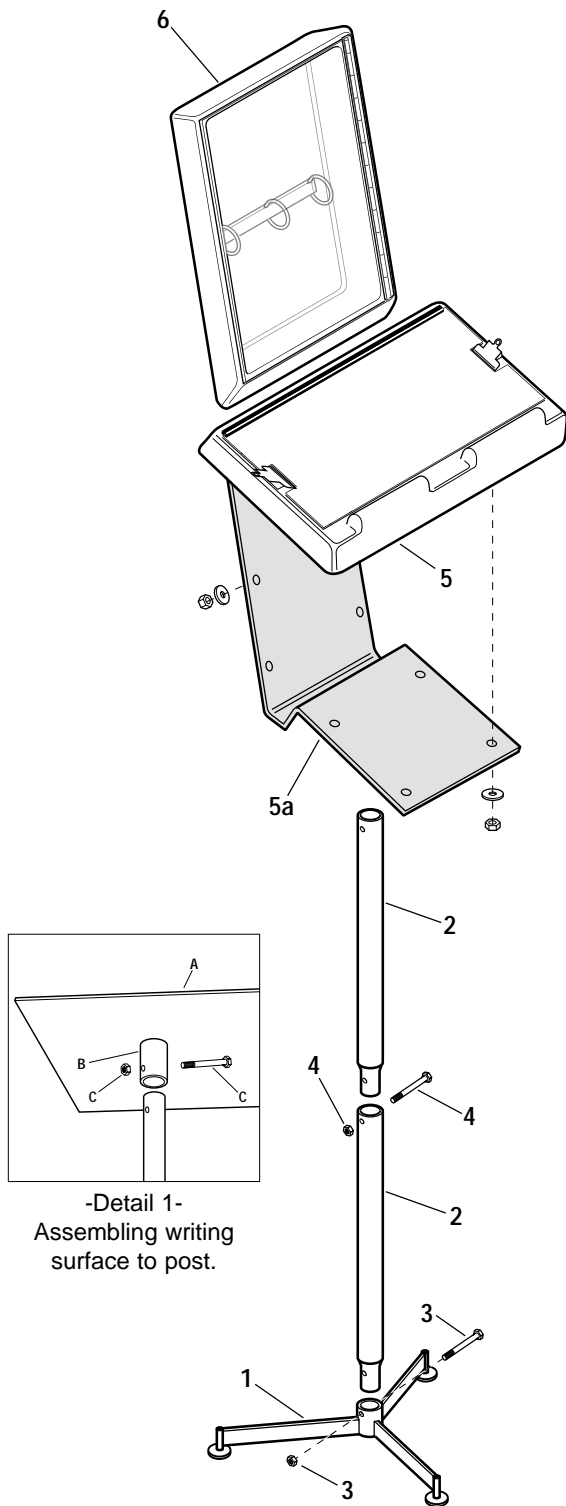

NOTE: This stand may be assembled with writing surface (item 5) at a height suitable for either standing use or seated use. To assemble for seated use, substitute 11" long post section for 22 1/2" long section (item 2).

Refer to illustration at left. *NOTE: The unit you are assembling may look slightly different than the illustration.*

1. Identify posts for stand (item 2).
2. Slide end of lower post (2) into base (1). Secure with screw and nut (3). Tighten. Slide upper post into top of lower post. Secure with screw and nut (4). Tighten. Snap glides into base.
3. Attach backing plate (item 5a) to studs on underside of writing panel (item 5) and to studs on back of display panel (item 6). Affix with flat washers and hex nuts.
4. Slide sleeve on panel/tray assembly onto top of stand. Secure with screw and nut (C on detail 1). Tighten.
5. Remove protective sheets from clear acrylic covers by running knife blade along edge of hinge and stripping off tinted plastic.



Workplace Solutions

P.O. Box 26 • 600 South Clark St.
Mayville, WI 53050
Phone: 920-387-4120
Fax: 920-387-4189