

Assembly Instructions 1200D Information Stand

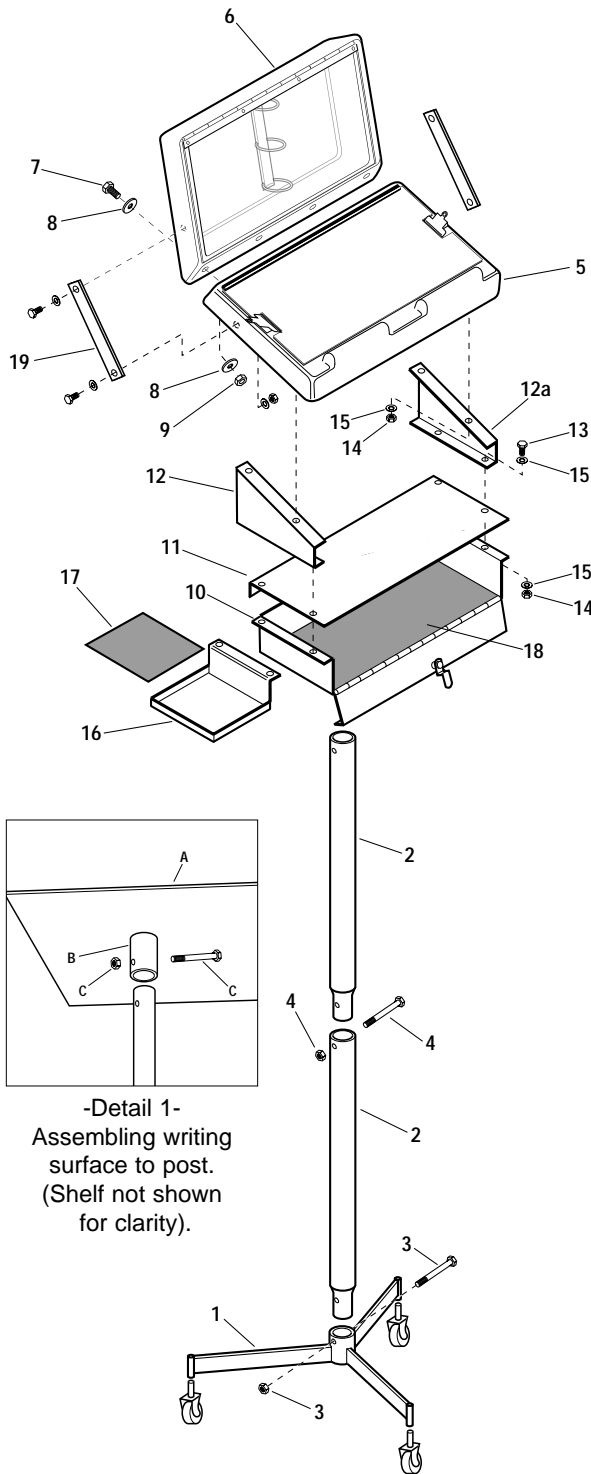

NOTE: This stand may be assembled with writing surface (item 5) at a height suitable for either standing use or seated use. To assemble for seated use, substitute 11" long post section for 22 1/2" long section (item 2).

Refer to illustration at left. *NOTE: The unit you are assembling may look slightly different than the illustration.*

1. Identify posts for stand (item 2).
2. Slide end of lower post (2) into base (1). Secure with screw and nut (3). Tighten. Slide upper post into top of lower post. Secure with screw and nut (4). Tighten. Install casters.
3. Locate adapter brackets (12 & 12a). Note that holes are near wide end on one flange and near narrow end on other flange.
4. Assemble locking tray (items 10, 11, 12, & 12a) as illustrated. Be sure adapter brackets are oriented as shown. Side tray (16) may be mounted on either side. Mount side tray beneath locking shelf flange.
5. Mount assembled tray unit to writing panel (item 5) using studs beneath writing surface. *NOTE: Do not remove backing plate attached to writing surface when connecting tray assembly to panels. Adapter brackets fit over the nuts attaching backing plate. Be sure shelf is in front of mounting sleeve (B on detail 1)*
6. Slide sleeve on panel/tray assembly onto top of stand. Secure with screw and nut (C on detail 1). Tighten.
7. Assemble display surface (6) to writing surface (5) using bolts, flat washers and hex nuts (7, 8, 9). Tighten securely.
8. Align side braces (19) as shown and mark holes. Drill 1/4" holes through panel sides. Affix braces to panels using screws, nuts and washers tighten securely.
9. Install neoprene liners (17 & 18) on trays.



Workplace Solutions

P.O. Box 26 • 600 South Clark St.
Mayville, WI 53050
Phone: 920-387-4120
Fax: 920-387-4189