

# MOBILE WIRE SPOOL CART

## SOLVES WIRING LOGISTICS

Here's the answer to production or maintenance wiring jobs. Roll the wire to the job, unspool what you need, and return the cart to a convenient storage place. Made of strong but light **WA50** aluminum rail with formed steel brackets, the cart measures 54" high, 36" deep and 33.6" wide. There is a 27" clear space between spool shaft brackets, which are fully adjustable. The cart is available with four heavy-duty casters (two fixed and two swivel with locks), two fixed casters and two glides or, for semi-permanent installation, with four glides. Swivel casters may be installed at either front or back. All components, except hardware, finished with chip-resistant baked polyester coating. Rails are beige and brackets are black. Some assembly required. **MAXIMUM CAPACITY: 300 lbs.**

Includes Bin Bar (bin boxes not included). Convenient storage for wire nuts and other fasteners or tools.

Formed steel brackets provide maximum rigidity. All assembly hardware included.

Adjustable hanging brackets clamp to C-rail.

Strong extruded aluminum frame.

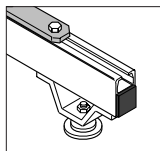
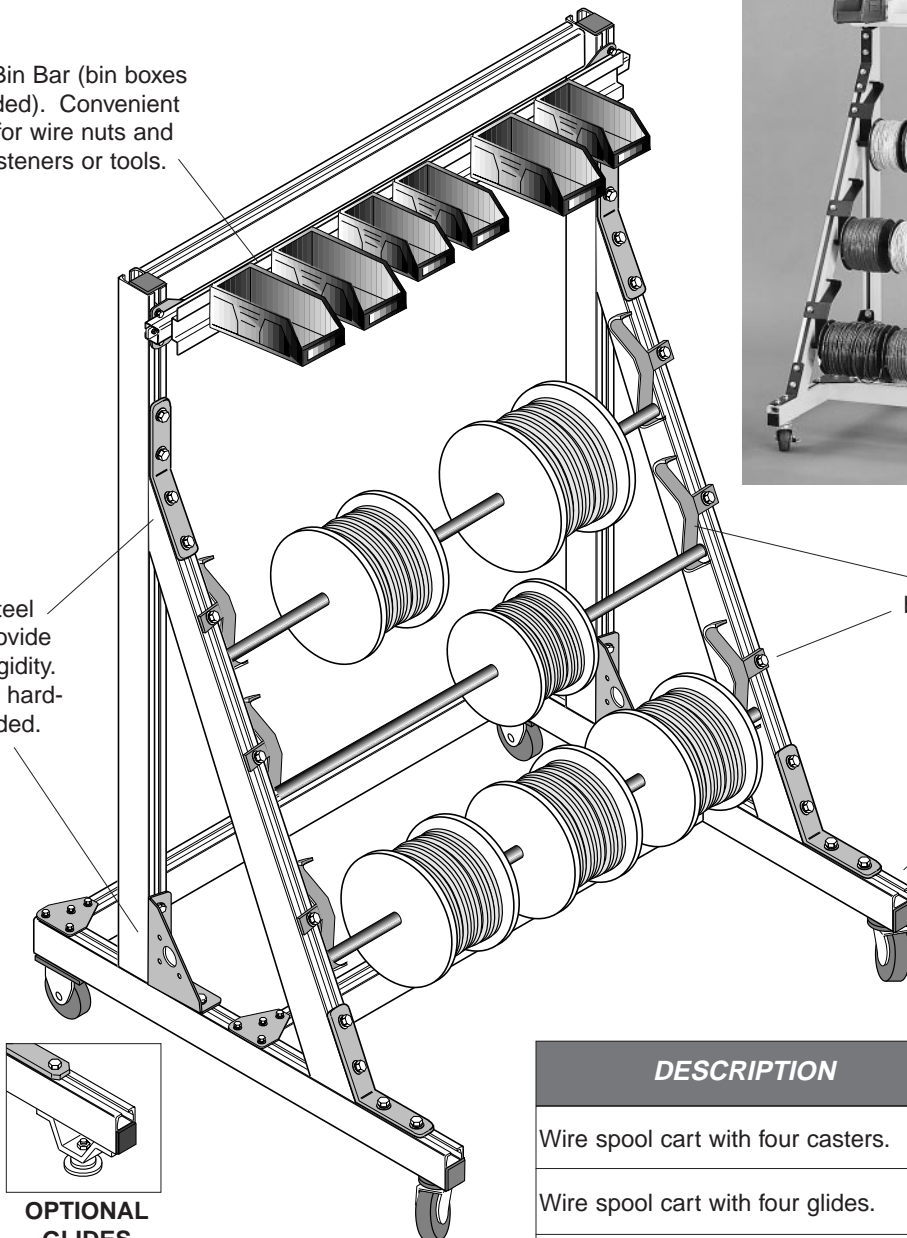

OPTIONAL GLIDES

DESCRIPTION	MODEL NUMBER
Wire spool cart with four casters.	HWP-RC01
Wire spool cart with four glides.	HWP-RC02
Wire spool cart with two fixed casters and two glides.	HWP-RC03



Workplace Solutions

P.O. Box 26 • 600 South Clark St. • Mayville, WI 53050-0026 • Phone 920-387-5195