

GANTRY TOOL CRANE

STRADDLES WORK AREA OR ASSEMBLY LINE

This highly versatile gantry tool crane can be assembled from standard components and kits. Capacity varies depending on which components are used. A 50 lb. capacity crane uses WS-50 components and a WS50-ET05 or WS50-ET06 tool crane kit. The rugged 250 lb. capacity unit is assembled from WS-60 components and a WS60-ET06 tool crane kit. To maintain full 250 lb. capacity, the rails on which the crane runs must be no more than 72" in length. Longer spans will decrease capacity. The cranes are designed to provide overhead tool support and are NOT designed for lifting. All but the casters are shown in the WS catalog. WS50 components have bake polyester finish. WS60 components are galvanized or zinc plated.

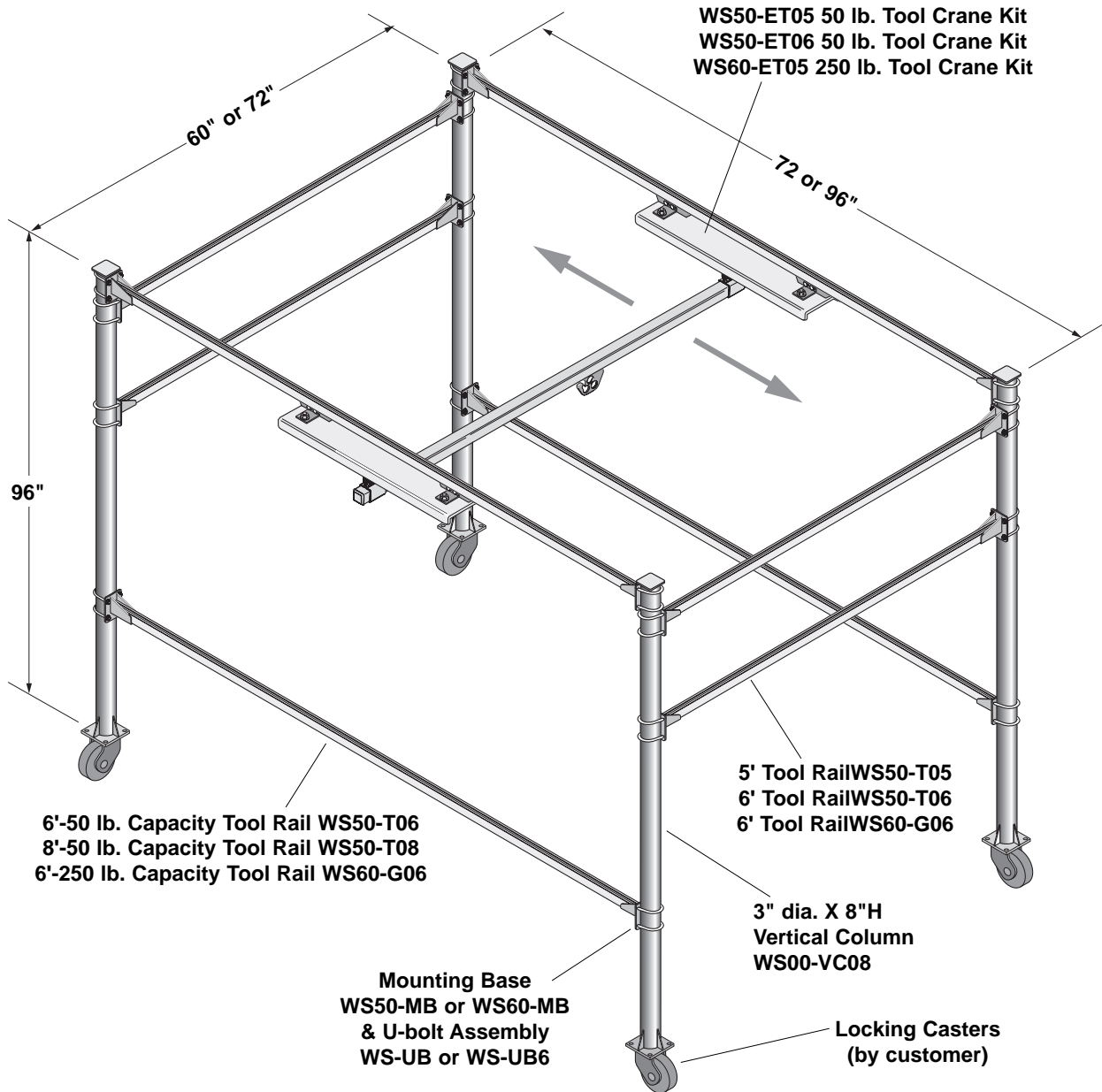

Workplace Solutions

P.O. Box 26 • 600 South Clark St. • Mayville, WI 53050-0026 • Phone 920-387-5195