

INSTALLATION INSTRUCTIONS

50 lb. CAPACITY TOOL SUPPORT CRANE

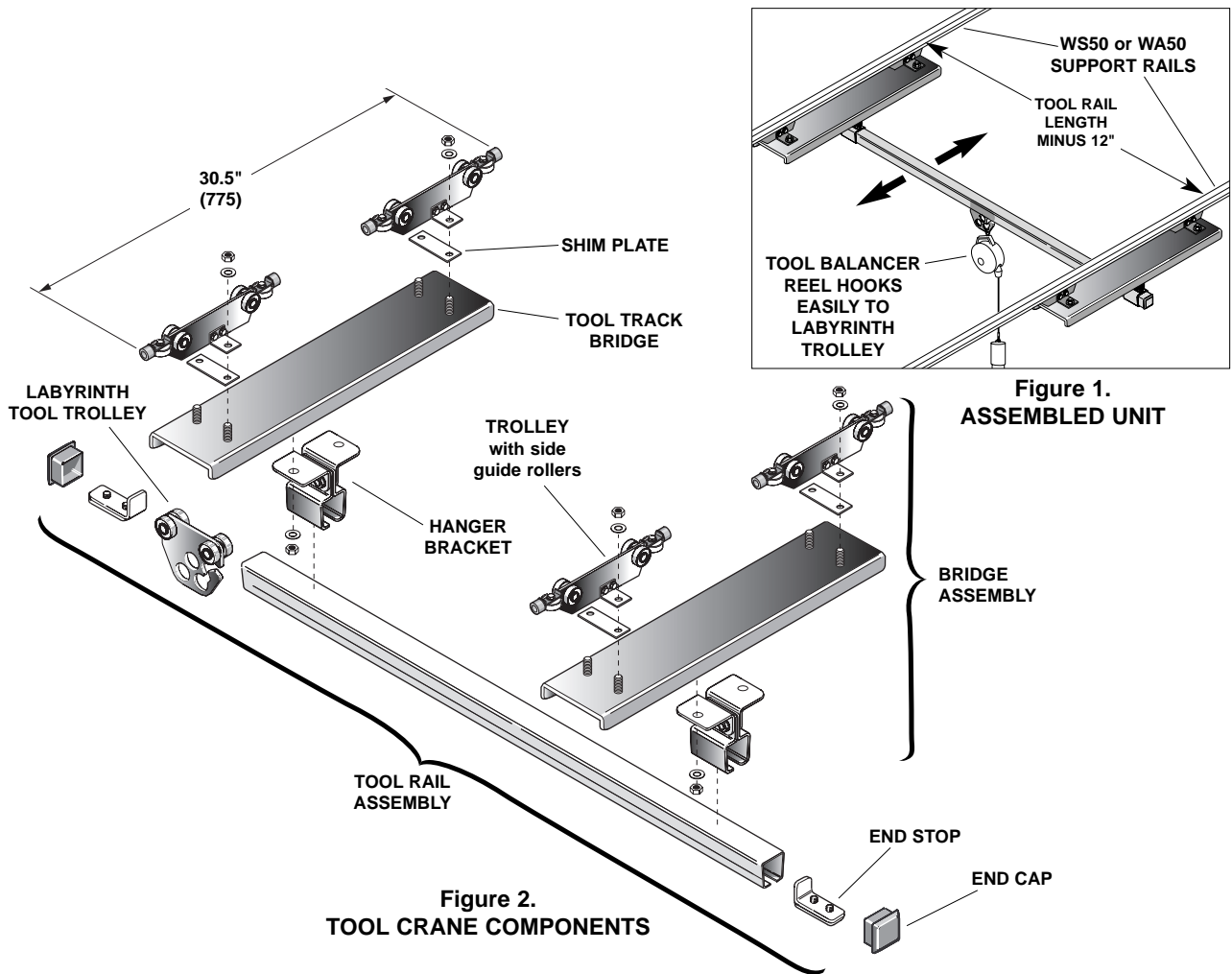

DESCRIPTION

The OVERHEAD TOOL CRANE is ideal for situations which require tool support over a larger area than normally provided by tool rails or jib booms. The tool crane consists of three assemblies; (2) bridge assemblies with trolleys and hanger brackets attached, and (1) tool rail with tool trolley, end stops and end caps. Two parallel support rails (*WS50 or WA50 track*) must be provided by the customer.

CAUTION

Maximum capacity, including tool, balancer and power hose or cord not to exceed 50 lbs.(22.5kg). Designed for use with portable tools only. USE WITH POWERED OR MANUAL HOIST NOT RECOMMENDED.

INSTALLATION

1. Check to be sure trolleys will roll freely in track that is to be used for supporting crane. Hang support rails following manufacturer's instructions. Rails

must be parallel and level. Recommended distance between rails is length of tool rail minus 12"(305mm). See Figure 1, above. Stops must be provided at each end but stops at one end of each rail must be left out until after tool crane is installed so that trolleys can be inserted into rails.

2. Slide bridge assembly trolleys into support rails. Install stops omitted in step 1. See Figure 2.
3. Slide tool rail thru hanger brackets on under side of bridge assemblies. See Figure 2.
4. Adjust and align all parts until crane rolls smoothly. Tighten hanger bracket clamp bolts and check to make sure all bolts in assembly are tight. Test unit.
5. Hang balance reel and/or tool on tool trolley.



Workplace Solutions

P.O. Box 26 • 600 South Clark St.
Mayville, WI 53050-0026
Phone: 920-387-5195