

INSTALLATION and MAINTENANCE INSTRUCTIONS

E-Z PULL™ SPRING OPERATED CLEAN AIR HOSE REELS

NOTE: E-Z PULL CLEAN AIR hose reels are provided without hose, mask or pressure regulator. Hose must be supplied by respirator face piece manufacturer and installed by customer .

⚠ WARNING

Use only hose supplied with mask. Do not substitute. Use of incorrect hose could lead to serious injury or death.

All units are provided with right hand rotation unless otherwise specified. This means that hose rotates **clockwise** to wind hose when viewing reel from **spring** (inlet) **side...opposite** when viewed from swivel joint (spooled hose connection) side.

Clock-type springs provide power for hose take-up. **Spring must be pretensioned at time of installation** to insure that tension is applied to hose at all times.

INSTALLATION

1. Securely mount reel in desired position using 3/8"(M10) bolts. Be sure spool centerline is aligned with hose run.
NOTE: E-Z PULL reel should be mounted 3' maximum above floor. Reel will not "LIFT" hose overhead.
2. Install hose. See HOSE INSTALLATION section on back page of these instructions.
3. Position hose guide. Guide must be oriented so hose pays off reel **horizontally**, in a straight line without bends.
4. Rotate spool counter-clockwise (when viewed from swivel joint side) until all hose is wound on reel...not extending through hose guide. See Figure 1.

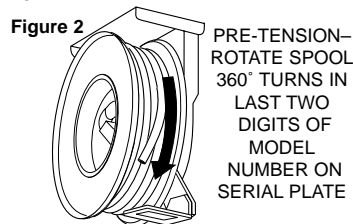
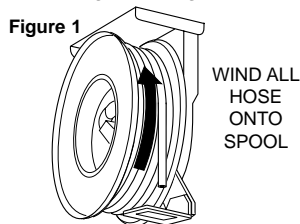

5. Pre-tension reel by rotating spool in clockwise direction (when viewed from swivel joint side). Full 360° turns should match last digit in model number on serial plate (normally three (3) full turns). See figure 2.
6. Engage ratchet lock to prevent spool from unwinding.
7. Feed hose end out through hose guide and pay-out hose to maximum working length. At least one turn of hose should remain on spool. If spool locks up prior to reaching required length, either reel was over-tensioned during step 5 or reel capacity has been exceeded. Failure to correct this condition will result in shortened spring life and possible damage to other reel components.
8. Attach hose stop and adjust free length of hose.
9. Connect supply hose, filter, regulator and gauge (supplied by others) to fitting on spring side of reel.
11. Turn on pressure to reel. Test for leaks.

RATCHET LOCK

Reel is shipped with ratchet lock "engaged". If constant spring tension is required, lock may be disengaged by locating and removing the selector plate anchor screw on the frame, rotating the selector plate to disengage position, and replacing and tightening the selector plate screw.

MAINTENANCE

Bearings and springs are prelubricated and require no periodic maintenance.

SPRING REPLACEMENT

⚠ WARNING

Do not attempt to remove spring from its housing. Clock-type springs can be dangerous to handle. Removal of spring from housing could result in personal injury.

The unique SAFETYCHANGE® spring motor consists of a spring sealed within a housing. A replacement spring is supplied sealed in its housing and the old unit should be discarded completely.

1. Turn off supply pressure to reel.
2. Remove attachments from hose. Remove hose stop.
3. Wind hose onto reel to relieve **all** spring tension.
4. Using a 3/16" allen wrench, loosen socket head screw in main shaft clamp nut. Support spool and spin nut off shaft.
5. Remove entire spool and spring motor assembly from frame.
6. Remove V-Ring seal from spring assembly.
7. Remove nuts holding spring assembly and slide spring assembly off main shaft.
8. Slide new spring assembly onto shaft and reassemble reel by reversing above steps.
9. Adjust spring tension. Refer to SPRING ADJUSTMENT.

HOSE REMOVAL

Use the following procedure to remove worn or damaged hose from reel prior to installation of new hose.

1. Turn off supply pressure to reel.

⚠ CAUTION

Failure to relieve all spring tension prior to removing hose could result in damage to equipment or personal injury. Follow instructions carefully.

2. Disconnect attachments from hose. Remove hose stop and allow hose to retract onto spool. Ensure all tension is off spring by manually rotating spool (normally clockwise when viewed from spring side).
3. Remove hose from spool by looping over spool flange.
4. Remove tube clamp from spool.
5. Remove hose from swivel joint located on inside of spool.
6. Pull hose out of hole in spool.
7. Slide tube clamp off hose.
8. Install new hose following directions on back page.

CONTINUED ON BACK PAGE



E-Z PULL CLEAN AIR HOSE REEL REPLACEMENT PARTS LIST

ITEM	KIT NO.	DESCRIPTION	QTY.
1	602332SB	Frame Assembly, 19" Reel	1
2	021484	Clamp Nut	1
3	025032	'V'-Ring Seal	1
4	604093	Locking Dog Repair Kit	1
5	028132	Hex Head Capscrew, M10 x 25L	3
6	028138	Lockwasher, M10	3
7	602333SB	Mount Bracket, 19" Reel	1
8	602341SB	Roller Guide Assembly, 19" Reel	1
9	028144	Lock Nut, M5 x 0.8, 19" Reel	8
10	05059836	Spring Assembly "K", 19" Reel	1
11	022734	Spring Gasket, 19" Reel	1
12	02748702	Shaft, Stainless Steel	1
13	602338SB	Spool Assembly, 19" Reel	1

ITEM	KIT NO.	DESCRIPTION	QTY.
14	602336SB	Flange Bushing, 19" Reel	1
15	028144	Lock Nut, M5 x 0.8	4
16	027406	Retaining Ring, 19" Reel	1
17	604063	Swivel Joint, Stainless Steel	1
18	602353	Adapter-1/2-14 to 3/4-16	1
19	604128	Tubing Clamp-3/8" Hose	1
20	103281	5/16 x 3/4 Soc. Hd. Cap Screw	1
21	101206	Flat Washer, 1/4"	2
22	023304	Lock Nut, 5/16	1
OPTIONAL ACCESSORIES			
	602073	Hose Stop, 19"-8 Reel	Option

Always specify **SERIAL NUMBER & MODEL NUMBER** when ordering parts.

E-Z PULL CLEAN AIR HOSE REEL

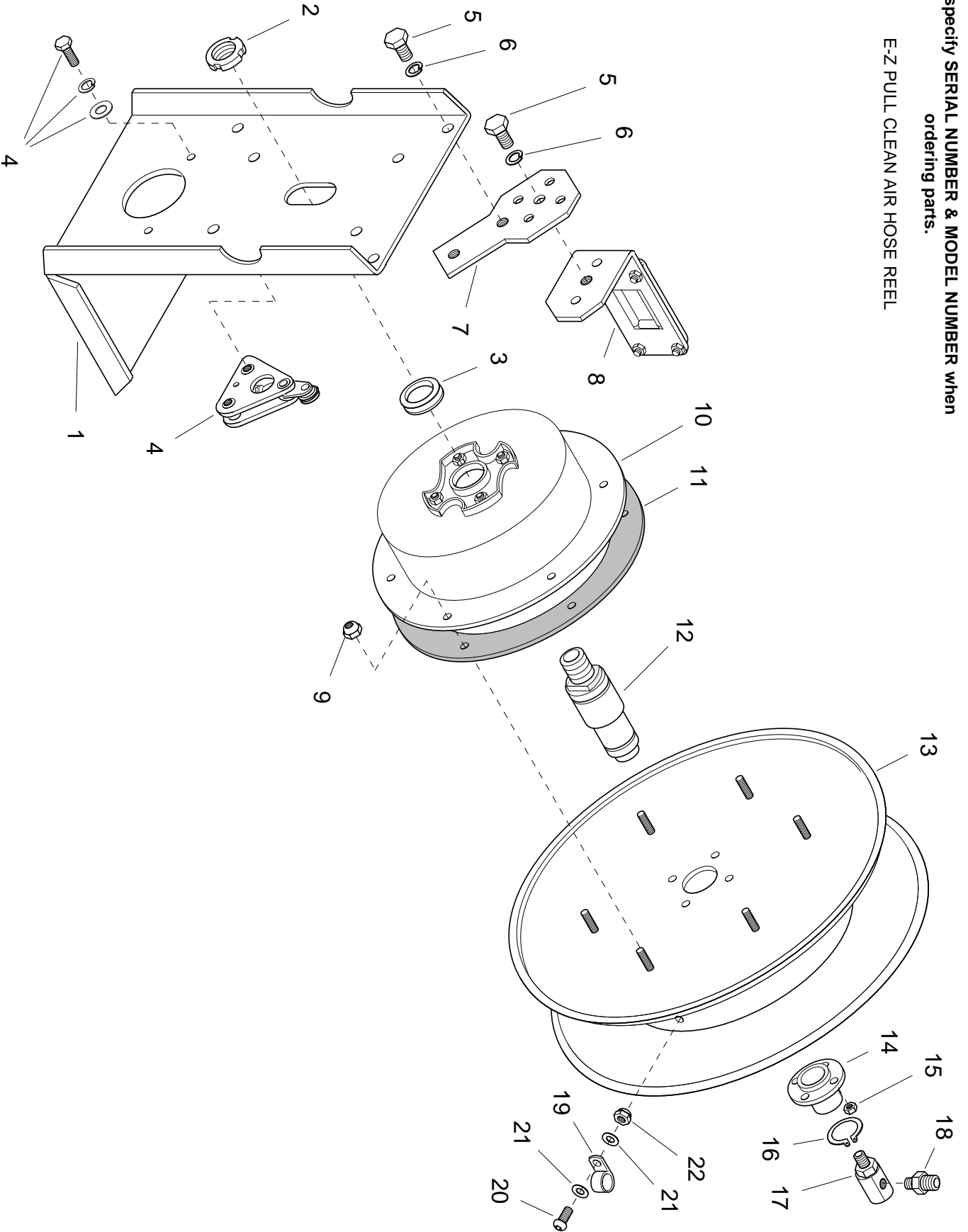

HOSE INSTALLATION

Use the following procedure to install hose during initial reel installation or to replace hose. Refer to HOSE INSTALLATION REFERENCE DRAWING, below.

1. Unspool new hose from shipping spool and lay out to eliminate twist.
NOTE: This step is not essential, but will aid in winding operation of the reel and prolong hose life.
2. Remove tube clamp from spool and slide onto hose. Be sure tube clamp is orientated so that loop on clamp will be next to outside spool flange.
3. Feed end of hose through hole in spool hub and connect to adapter on swivel joint fitting. (See drawing below).
4. Align tube clamp on hose with hole in spool hub. Fasten with socket head screw, washers, and lock nut.
5. Wind the hose onto the reel spool by hand rotating spool in direction it turns free of spring tension. (Normally clockwise when viewed from spring side)
6. Adjust hose stop.
7. Complete working end connections.
8. Pretension reel and complete installation as described in INSTALLATION section.

SPRING ADJUSTMENT

Adjust tension by adding wraps (increasing tension) or removing wraps (decreasing tension) from the spool.

1. Pull about 10' of hose, allowing spool to rotate.

INCREASE TENSION: Without allowing spool to rotate, hand feed hose back through hose guide until loop is large enough to slip onto spool. **Add** two or three wraps until desired tension is achieved. See Figure 3.

DECREASE TENSION: Without allowing spool to rotate, hand feed hose back through guide to provide slack. **Remove** one or two wraps from spool. See Figure 4.

2. Test reel operation.

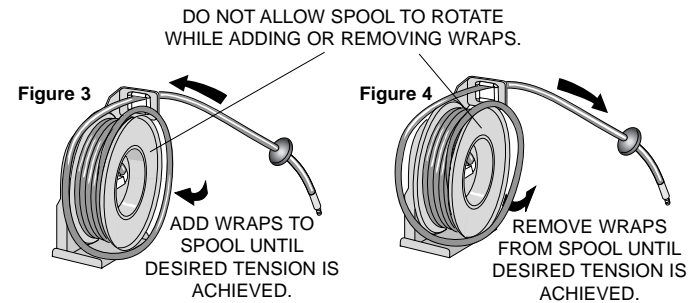

HOSE INSTALLATION REFERENCE DRAWING

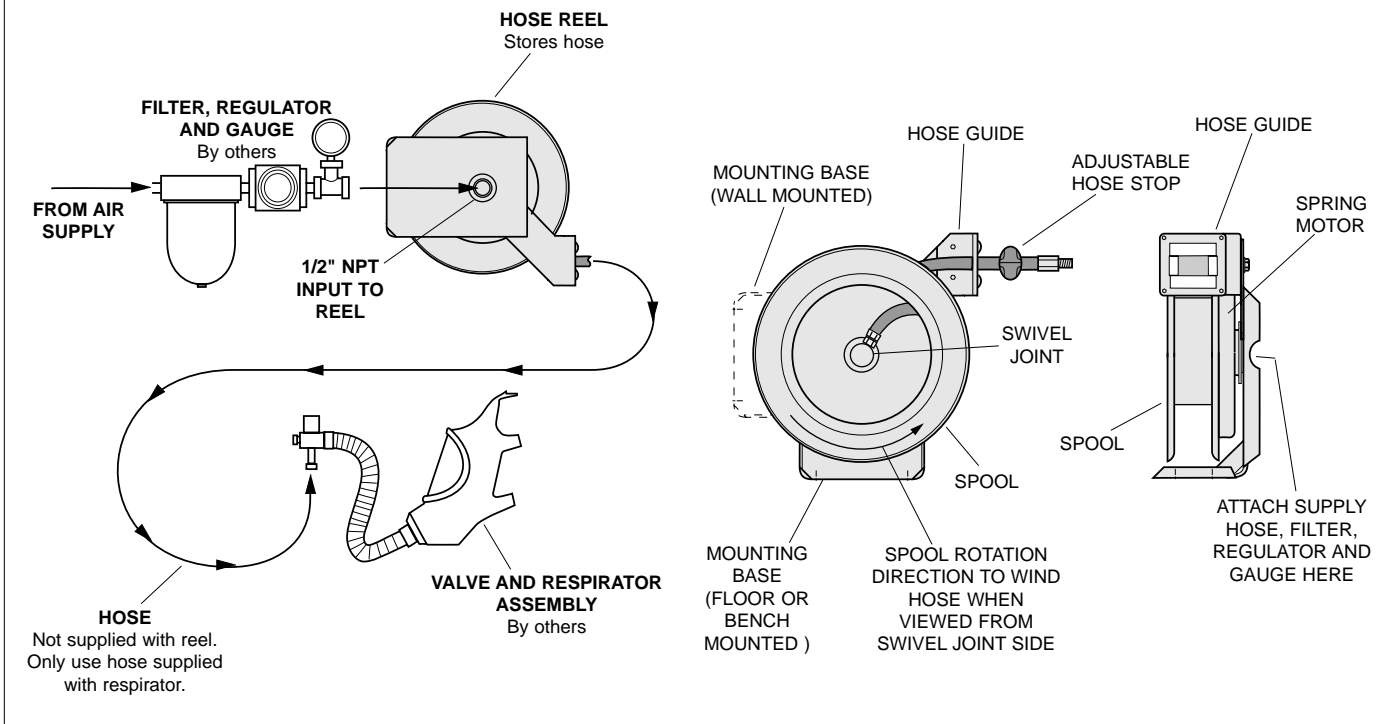

Workplace Solutions

P.O. Box • 600 South Clark St.
Mayville, WI 53050
Phone 920-387-5195