

TEST BED CART

MOUNT ELECTRICAL BOX, OTHER TEST EQUIPMENT...ROLL TO JOB

The model HWP-TC01 Test Bed Cart represents the ultimate in versatility. Dual electrical box support rails adjust to any size box. Box mounts easily with exclusive **E-Z NUT™** Trak Nuts, furnished. Two coil hangers keep cable off floor while cart is being rolled to the job. Heavy duty shelf easily supports even the heaviest technical manuals. Bin Bar holds box bins for miscellaneous storage. Frame is strong extruded aluminum with beige baked polyester finish. All joining brackets are heavy steel with matte black polyester. Includes four locking, swivel casters and all assembly hardware. Bin boxes, electrical box and cables not included. Some assembly required.

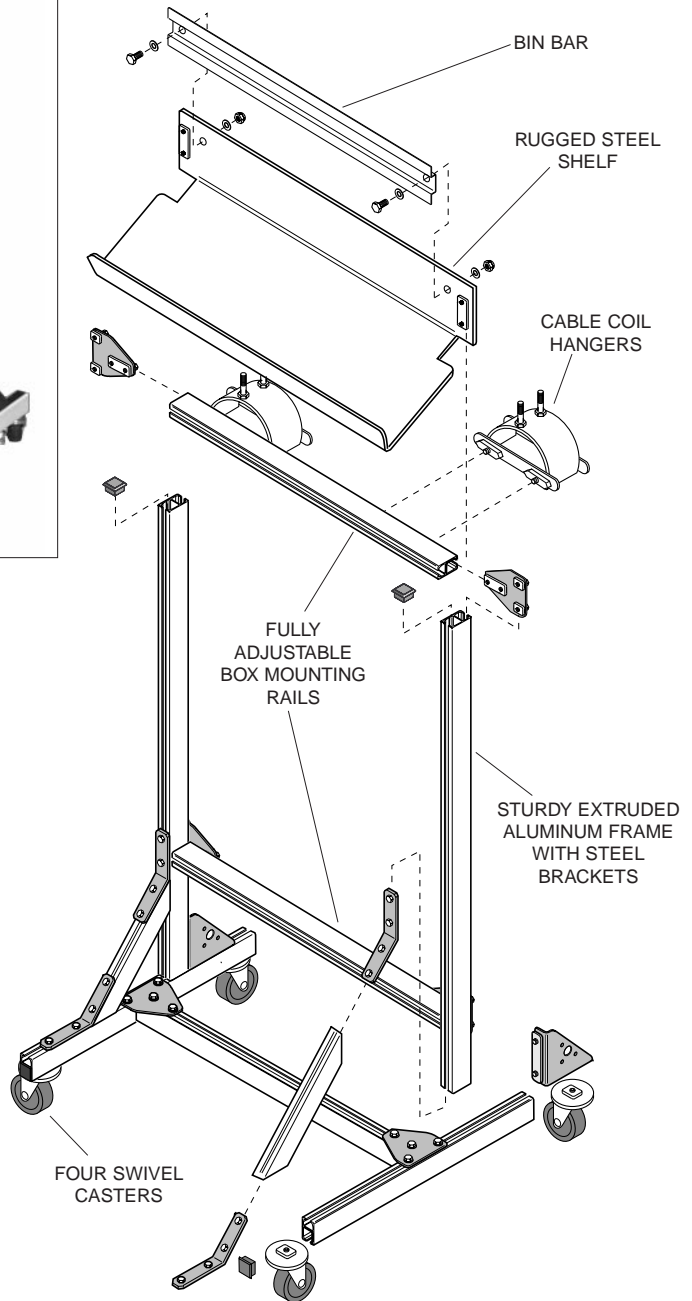

MODEL NUMBER
HWP-TC01



Workplace Solutions

P.O. Box 26 • 600 South Clark St. • Mayville, WI 53050-0026 • Phone 920-387-5195