

Push 'n Place™ WORKSTATION

A WORKSTATION WHERE YOU NEED IT

Here's a way to maintain flexibility on the plant floor without sacrificing safety and productivity. The Hubbell Workplace Solutions *Push 'n Place* portable workstation moves to where the action is. It rolls easily on four heavy-duty locking, swivel casters. Constructed of light but strong extruded aluminum rail, it measures 36" deep and 90" high, including casters. Frame is 44" wide o.c., perfect for under a 5' conveyor section, while the tool bar is 60" long and can be fitted with splice angles to adjoin two or more units. Bin Bar, air manifold and balancer trolley with fitting plus 3/8" hose are standard. Frame is finished with beige baked polyester. Brackets are matt black.

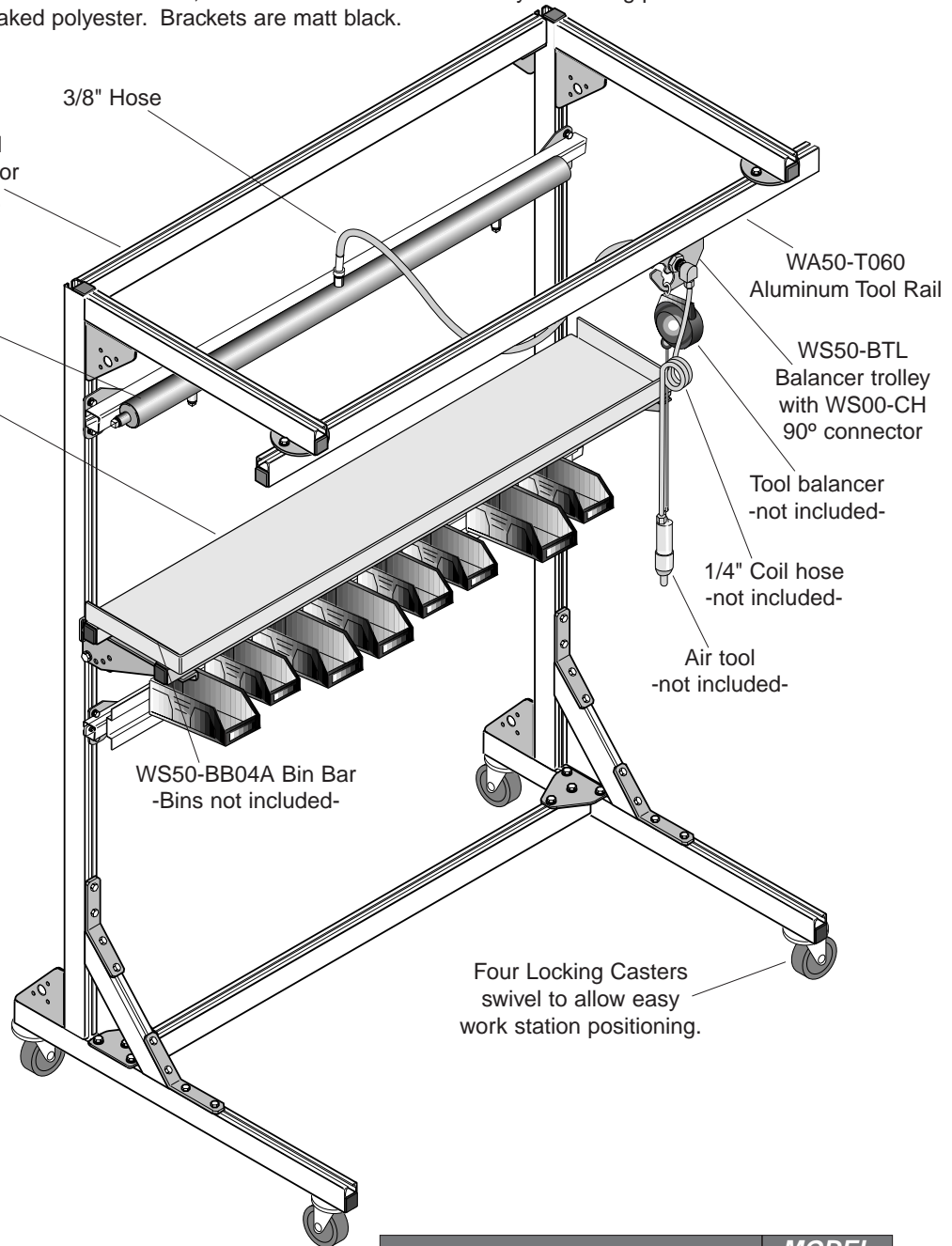

NOTE:
Standard Hubbell Workplace Solutions swing arms and other accessories may be used with portable workstation. Please refer to Workplace Solutions catalog or contact your local distributor.

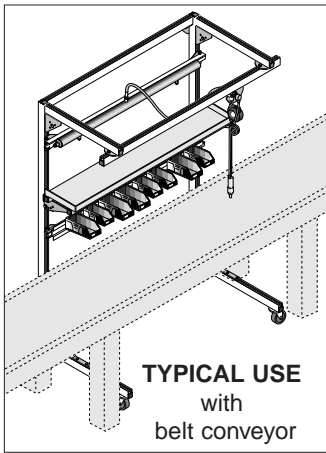

DESCRIPTION	MODEL NUMBER
Push 'n Place portable workstation	HWP-0475



Workplace Solutions

P.O. Box 26 • 600 South Clark St. • Mayville, WI 53050-0026 • Phone 920-387-5195