

# NO KIT TO FIT? SO MAKE ONE. FOR EXAMPLE...

Workstation kits in the catalog stop at 6' width. But, you don't have to stop there. When your customer has benches wider than 6', put together your own design using components from the **ECONOLINE WS** catalog. Shown here are the components used to assemble a workstation for use on an **8' to 9' wide** bench. A similar procedure would be used for other bench sizes.

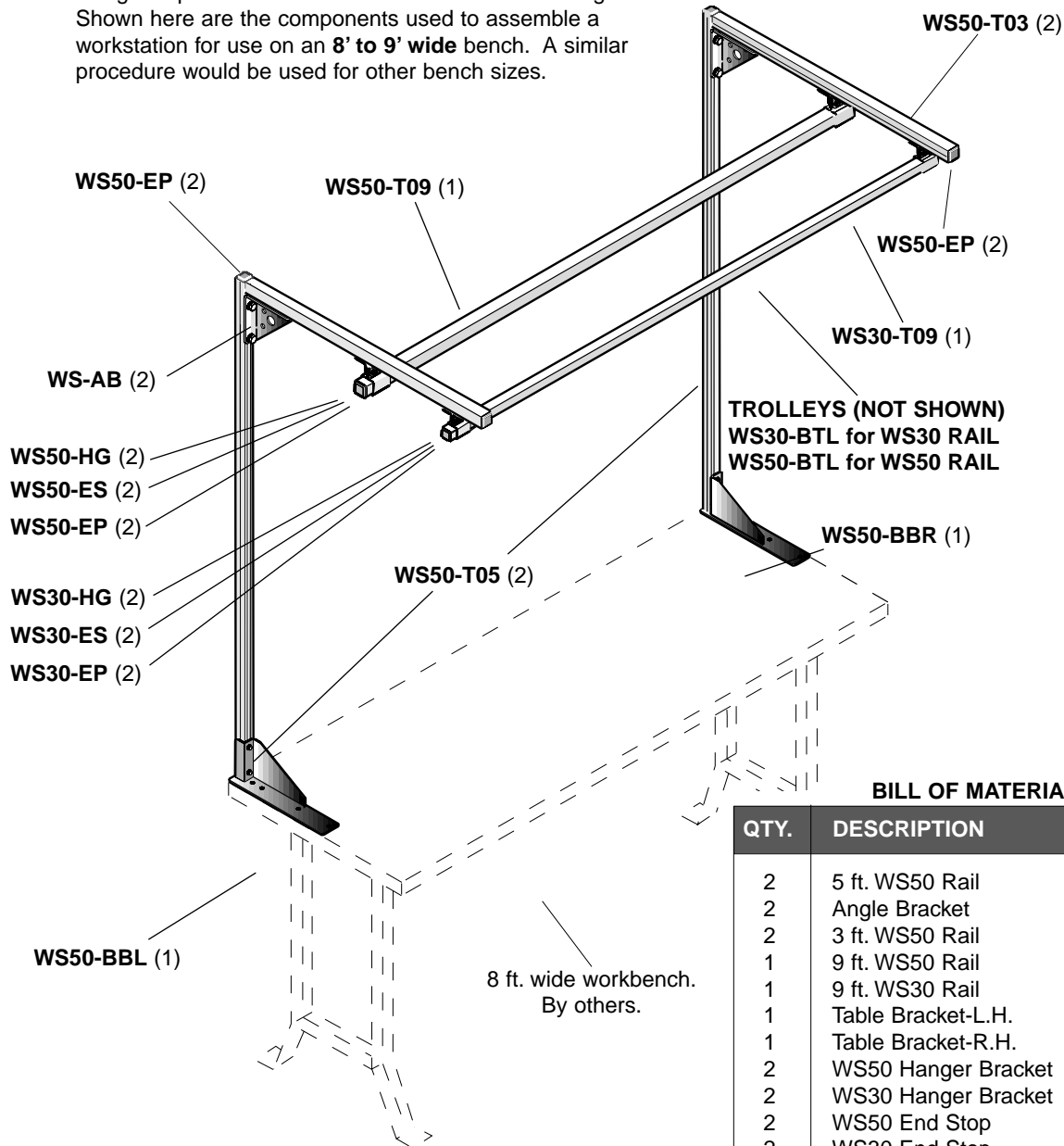

### BILL OF MATERIALS

QTY.	DESCRIPTION	MODEL NO.
2	5 ft. WS50 Rail	WS50-T05
2	Angle Bracket	WS-AB
2	3 ft. WS50 Rail	WS50-T03
1	9 ft. WS50 Rail	WS50-T09
1	9 ft. WS30 Rail	WS30-T09
1	Table Bracket-L.H.	WS50-BBL
1	Table Bracket-R.H.	WS50-BBR
2	WS50 Hanger Bracket	WS50-HG
2	WS30 Hanger Bracket	WS30-HG
2	WS50 End Stop	WS50-ES
2	WS30 End Stop	WS30-ES
6	WS50 End Cap	WS50-EP
2	WS30 End Cap	WS30-EP
1	WS50 Balancer Trolley	WS50-BTL
	or	
1	WS30 Balancer Trolley	WS30-BTL

