

150 lb. JIB FOR BIG TOOLS

KEEPS LARGE AIR OR ELECTRIC TOOLS SUSPENDED OVERHEAD

Extra-heavy duty jib is ideal for Series "EH" balancers with heavy torque wrenches and similar equipment. Boom swings full 360° but swing may be limited by optional stops. 6', 8' or 10' boom is rugged WS60 rail with ladder reinforcing. Ten foot high vertical column is 4" i.d. schedule 40 pipe. Boom supported by tapered bearing and heavy-duty rollers. Includes wire rope festoon system with two trolleys.

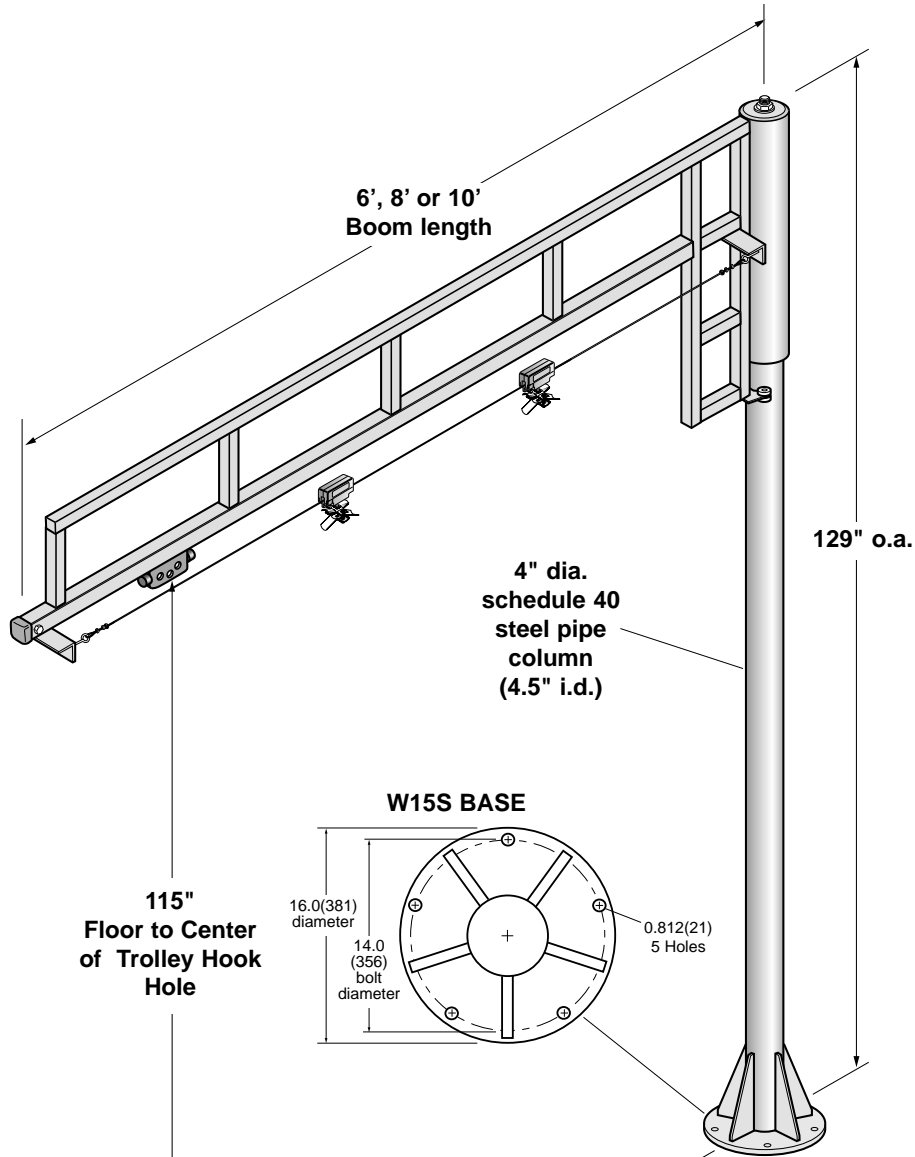

150 lbs.(67.5kg) capacity Jib.

Boom is WS60 rail. Column is 4" schedule 40 steel pipe.

| | | | |
|-----------------------|------------|------------|--------------|
| 6.0 (3.0) | 360° Swing | 10.0 (3.0) | #W15S-100600 |
| 8.0 (3.0) | 360° Swing | 10.0 (3.0) | #W15S-100800 |
| 10.0 (3.0) | 360° Swing | 10.0 (3.0) | #W15S-101000 |
| * Full Rotation Stops | | | #W6S-SK |



Workplace Solutions

P.O. Box 26 • 600 South Clark St. • Mayville, WI 53050-0026 • Phone 920-387-5195