



SERIES H and E-Z HOSE REELS

HEAVY DUTY FOR MACHINE PULL or
E-Z PULL™ FOR GENTLE HAND PULL

Heavy duty hose reels are designed for supplying air or fluid to machines in applications where the machine supplies the power to pull out the hose and the reel supplies the rewinding power. They are also widely used overhead where the hose is pulled down by hand. In hand pull applications, a ratchet lock is usually employed to keep the hose extended while in use.

E-Z PULL™ REELS are designed to make hose handling safer and smoother and to minimize costly replacement caused by excessive rewind speeds. Rewind pull is kept to a minimum resulting in a reel that is gentle to pull out, yet very adequate to rewind the hose. In some situations, the rewind pull provided by E-Z™ PULL reels may require a gentle assist from the operator. E-Z PULL™ reels should be mounted a maximum 3 ft.(0.9m) above the floor so that the hose may be pulled horizontally. Typical mounting is under a workbench.

BOTH REELS FEATURE:

- 1/4", 3/8", or 1/2" (6, 9, 13mm) hose
- All welded solid steel construction
- Fully automatic; Machine mountable
- Heavy duty mounting bracket
- Safetychange® spring motor
- Weatherproof gasket on spring motor
- Positive ratchet lock with disengage
- Multi-position adjustable hose guide
- Orange polyester baked-on finish
- Adjustable hose stop included
- Optional 340° pivot base

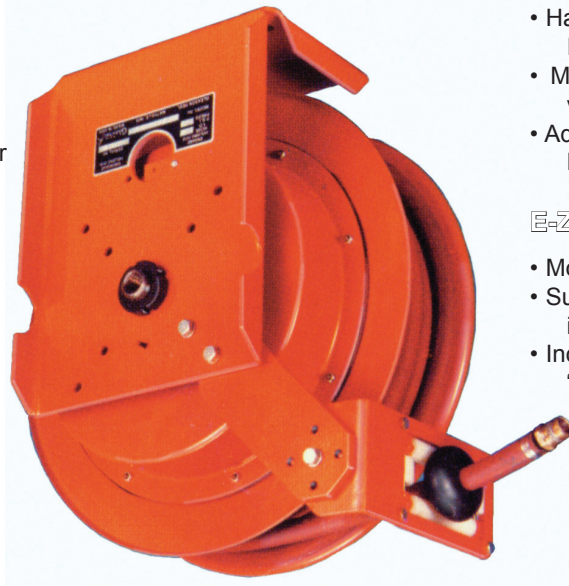

SERIES "H" APPLICATION:

- Connect machines to air/water supply.
- Hand pull, with or without ratchet stop. Ideal for fluids, compressed air.
- Mount base up, down or to wall for vertical or horizontal hose travel.
- Add optional 340° pivot base. Reel turns to follow hose pay-out.

E-Z™ PULL APPLICATION:

- Mount under workbench or low on wall.
- Supply air to tools, compressed air for inflating or cleaning.
- Increase safety...hose does not "fly back" to reel.

HOSE DATA				MACHINE USE OR OVERHEAD MOUNTED HAND PULL -MODEL NO.-	REEL SIZE	E-Z™ PULL FOR HORIZONTAL HAND PULL APPLICATIONS -MODEL NO.-	REEL SIZE	NET WEIGHT lbs. (kg)	HOSE STOP	340° BASE (OPT)	
INSIDE DIA. in. (mm)	INPUT & OUTPUT FITTINGS	MAX LENGTH ft. (m)	MAX PRES. psi (N/mm ²)								
1/4 (6)	0.25 NPTF	25 (7.5)	315 (2.17)	HC2525	A	EZ4-2525	A	30 (13)	CP-2	PB14	
		35 (10.5)		HC2535		EZ4-2535					
		50 (15.0)		HE2550		EZ9-2550					
3/8 (9)	0.38 NPTF	25 (7.5)		HC3825		A	EZ4-3825	A			30 (13)
		35 (10.5)		HD3835			EZ4-3835				
		50 (15.0)		HF3850			EZ9-3850				
1/2 (13)	0.50 NPTF	25 (7.5)		HG5025	B	EZ9-5025	B	62 (28)	CP-3	PB19	
		35 (10.5)		HG5035		EZ9-5035					
		50 (15.0)		HG5050		EZ9-5050					

REEL AND PIVOT BASE DIMENSIONS

All dimensions in inches. For millimeters, multiply inches by 25.4.

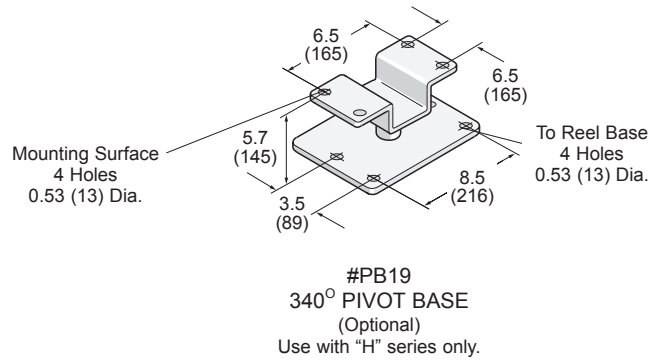
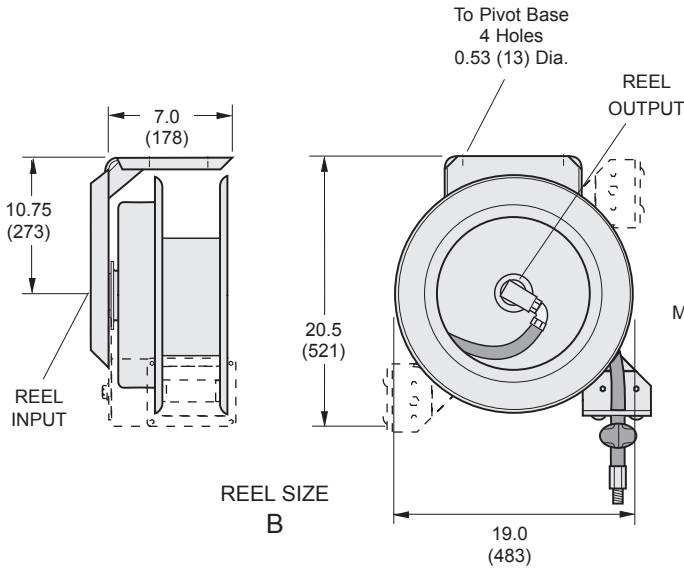
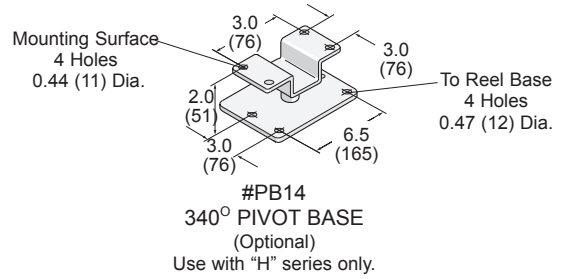
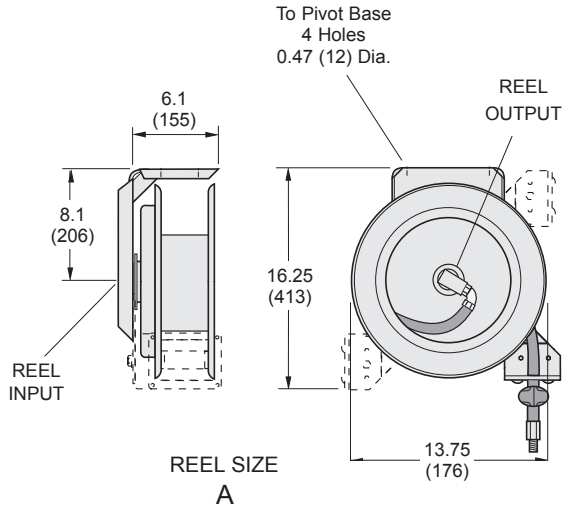

Brake Products, Inc.

16751 Hilltop Park Place

Chagrin Falls, Ohio 44023

Phone: (440) 543-7962 • Fax: (440) 543-7963

Web: www.brakeproducts.com