

GLEASON® PowerTrak

EF Type Model PT80EF-WH Parts List

ITEM	DESCRIPTION	PART NO.
1	Outer Link with Flange	P80E-99
2	Inner Link-10.50 radius	P80E-01
	" 12.50 radius	P80E-02
	" 19.50 radius	P80E-03
	" 23.12 radius	P80E-04
3	Anti-friction Plate	029011
4-6	-See Below-	
7	Socket Head Cap Screw	029173
8	Flanged Bushing	04952101
9	Washer	04952201
10	Hex Locknut	028146
11	Shim Washer, 1.22 ID x .01 thick*	029022
12	Shim Washer, 1.22 ID x .02 thick*	029023
13	Skt. Hd. CSCR, M8-1.25 x 20	029020
14	Lockwasher, M8	023279
15	Mounting Bracket, L.H.	P07-347
16	Mounting Bracket, R.H.	P07-348

* Not required on all systems.

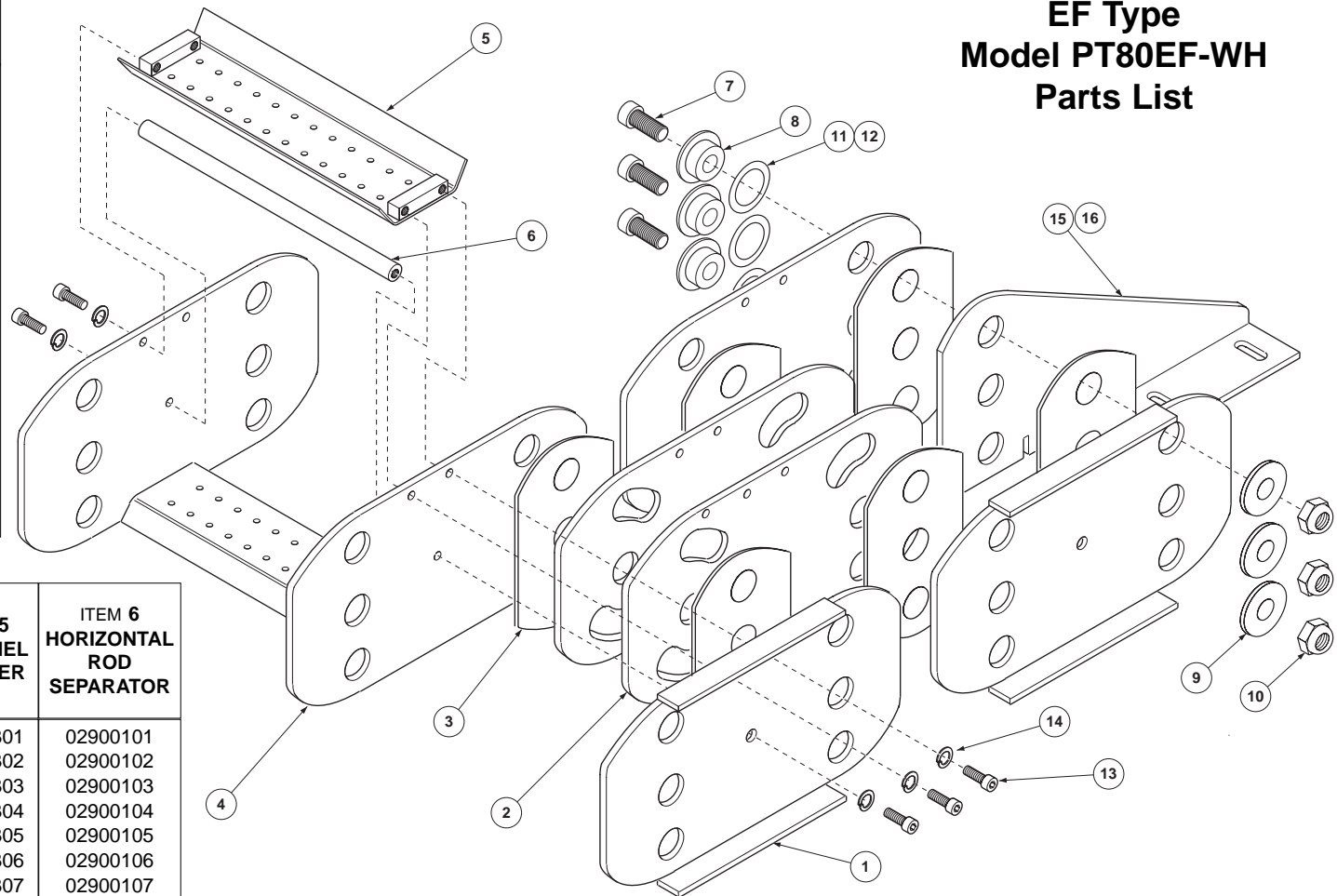

CARRIER WIDTH	ITEM 4 CHANNEL WELDMENT W/ HOR. ROD 10.5" RAD. ONLY	ITEM 4 CHANNEL WELDMENT	ITEM 5 CHANNEL CARRIER	ITEM 6 HORIZONTAL ROD SEPARATOR
8.00"	02901501	02901401	02901301	02900101
10.00"	02901502	02901402	02901302	02900102
12.00"	02901503	02901403	02901303	02900103
14.00"	02901504	02901404	02901304	02900104
16.00"	02901505	02901405	02901305	02900105
18.00"	02901506	02901406	02901306	02900106
20.00"	02901507	02901407	02901307	02900107
22.00"	02901508	02901408	02901308	02900108
24.00"	02901509	02901409	02901309	02900109



GLEASON REEL CORP.
P.O. Box 26 • 600 South Clark St.
Mayville, WI 53050-0026
Phone 920-387-4120 • Fax 920-387-4189