

GLEASON® PowerTrak®

EF Type Model PT80EF-HN Parts List

ITEM	DESCRIPTION	PART NO.
1	Outer Link with Flange	P80E-99
2	Inner Link--12.50 radius	P80E-02
	" 19.50 radius	P80E-03
	" 23.12 radius	P80E-04
3	Anti-friction Plate	029011
4 - 7	-See Below-	
8	Socket Head Cap Screw	029173
9	Flanged Bushing	04952101
10	Washer	04952201
11	Hex Locknut	028146
12	Shim Washer, 1.22 ID x .01 thick*	029022
13	Shim Washer, 1.22 ID x .02 thick*	029023
14	Skt. Hd. CSCR, M8-1.25 x 20	029020
15	Lockwasher, M8	023279
16	Mounting Bracket, L.H.	P07-347
17	Mounting Bracket, R.H.	P07-348

* Not required on all systems.

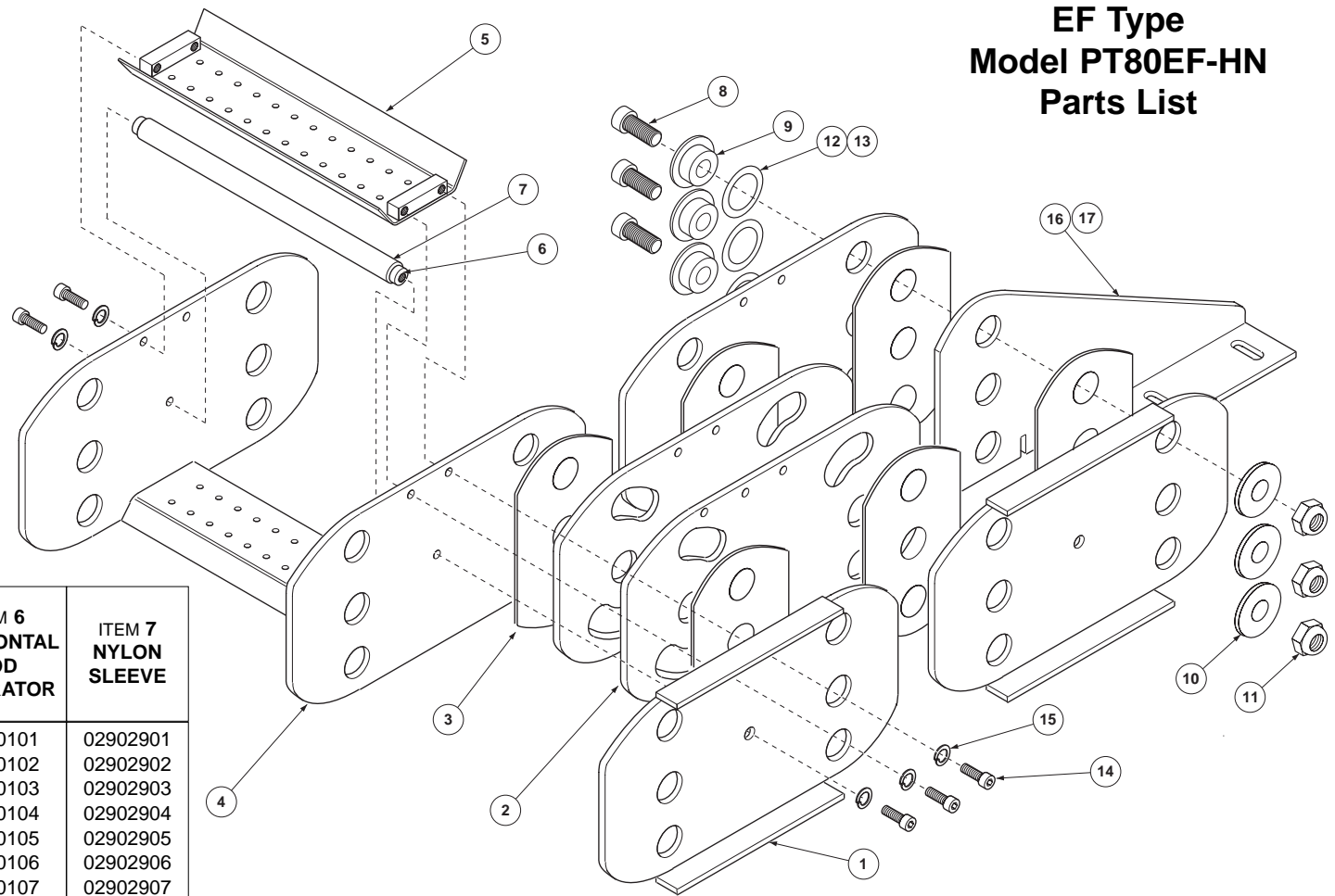

CARRIER WIDTH	ITEM 4 CHANNEL WELDMENT	ITEM 5 CHANNEL CARRIER	ITEM 6 HORIZONTAL ROD SEPARATOR	ITEM 7 NYLON SLEEVE
8.00"	02901401	02901301	02900101	02902901
10.00"	02901402	02901302	02900102	02902902
12.00"	02901403	02901303	02900103	02902903
14.00"	02901404	02901304	02900104	02902904
16.00"	02901405	02901305	02900105	02902905
18.00"	02901406	02901306	02900106	02902906
20.00"	02901407	02901307	02900107	02902907
22.00"	02901408	02901308	02900108	02902908
24.00"	02901409	02901309	02900109	02902909



GLEASON REEL CORP.
P.O. Box 26 • 600 South Clark St.
Mayville, WI 53050-0026
Phone 920-387-4120 • Fax 920-387-4189