

GLEASON® PowerTrak®

EF Type Model PT80EB-WC Parts List

ITEM	DESCRIPTION	PART NO.
1	Outer Link W/ Flange	P80E-98
2	Inner Link—10.50 radius	P80E-01
	" 12.50 radius	P80E-02
	" 19.50 radius	P80E-03
	" 23.12 radius	P80E-04
3	Anti-friction Plate	029011
4 & 5	—See Below—	
6	Bushing Bolt	P04-72
7	Lock Nut	029016
8	Shim Washer, 1.22 ID x .01 thick	029022
9	Shim Washer, 1.22 ID x .02 thick	029023
10	Skt. Hd. CSCR, M8-125 x 20	029020
11	Lockwasher, M8	023279
12	Mounting Bracket, L.H.	P07-347
13	Mounting Bracket, R.H.	P07-348

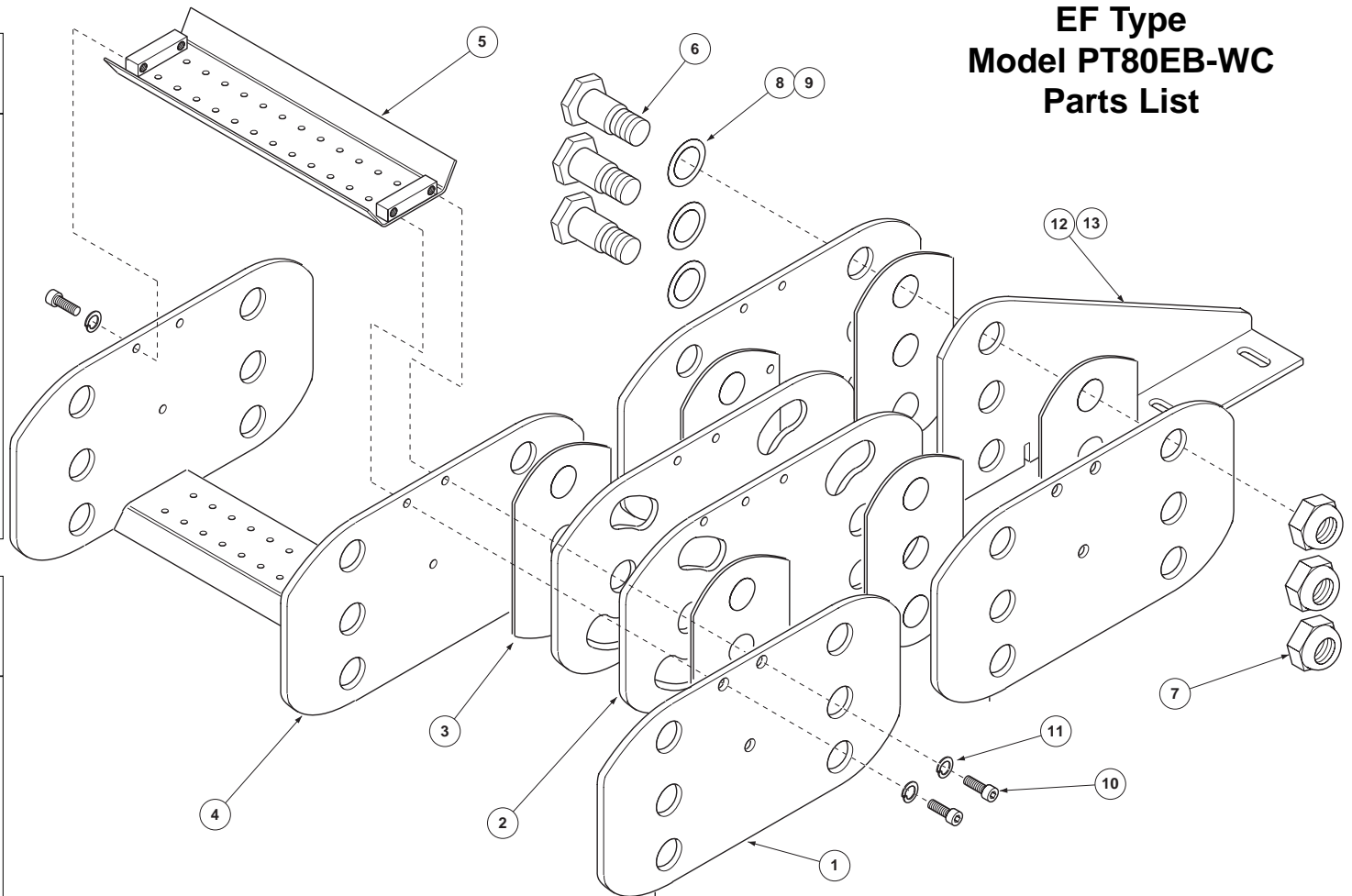

CARRIER WIDTH	ITEM 4 CHANNEL WELDMENT	ITEM 5 CHANNEL CARRIER
8.00"	02901401	02901301
10.00"	02901402	02901302
12.00"	02901403	02901303
14.00"	02901404	02901304
16.00"	02901405	02901305
18.00"	02901406	02901306
20.00"	02901407	02901307
22.00"	02901408	02901308
24.00"	02901409	02901309



GLEASON REEL CORP.
P.O. Box 26 • 600 South Clark St.
Mayville, WI 53050-0026
Phone 920-387-4120 • Fax 920-387-4189