

GLEASON® PowerTrak®

E Type Model PT80E-WH Parts List

ITEM	DESCRIPTION	PART NO.
1	Outer Link	P80E-98
2	Inner Link—10.50 radius	P80E-01
	" 12.50 radius	P80E-02
	" 19.50 radius	P80E-03
	" 23.12 radius	P80E-04
3	Anti-friction Plate	029011
4-6	—See Below—	
7	Hinge Pin	P04-75
8	Retaining Ring	015359
9	Shim Washer, 1.22 ID x .01 thick	029022
10	Shim Washer, 1.22 ID x .02 thick	029023
11	Skt. Hd. CSCR, M8-125 x 20	029020
12	Lockwasher, M8	023279
13	Mounting Bracket, L.H.	P07-347
14	Mounting Bracket, R.H.	P07-348

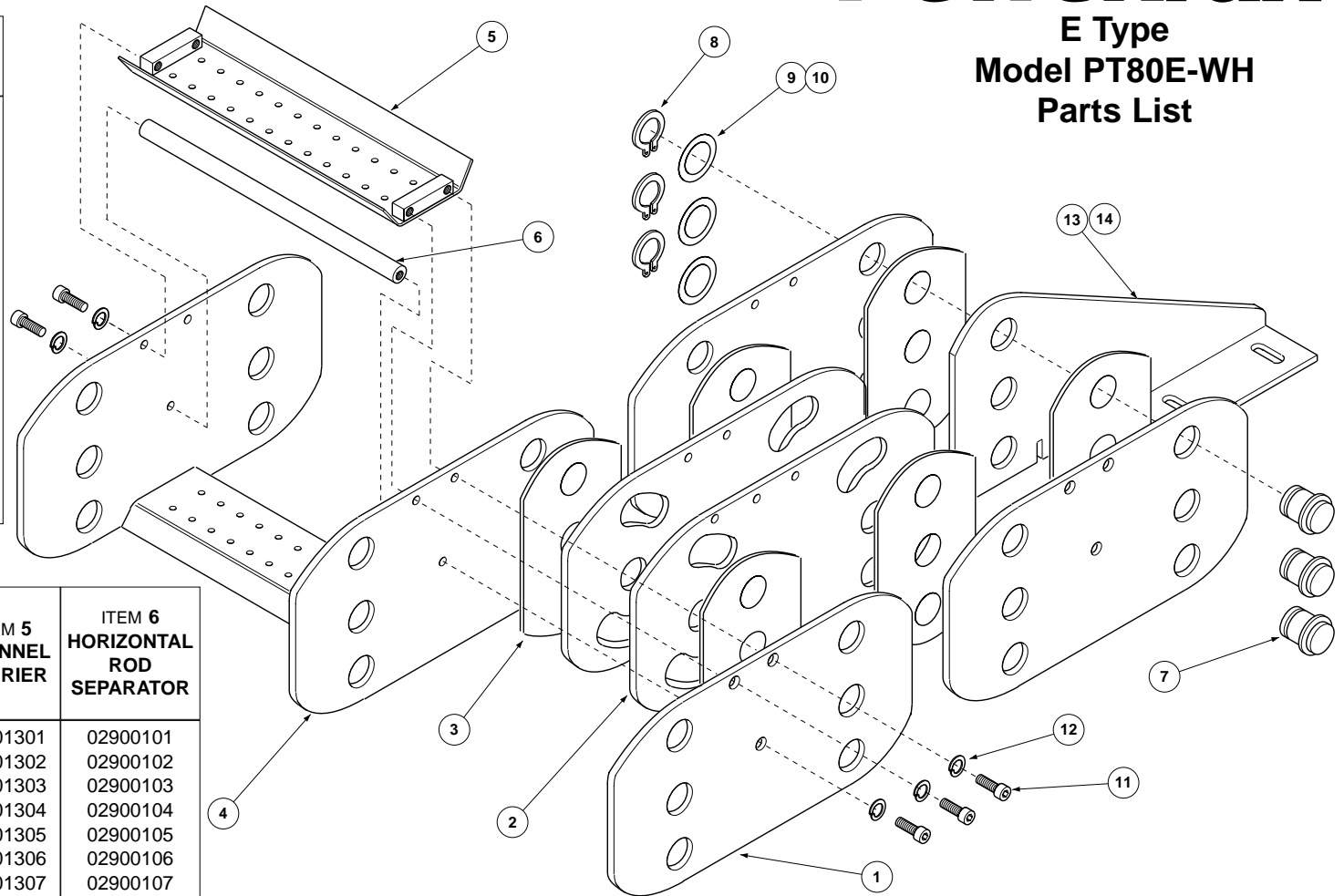

CARRIER WIDTH	ITEM 4 CHANNEL WELDMENT W/ HOR. ROD 10.5" RAD. ONLY	ITEM 4 CHANNEL WELDMENT	ITEM 5 CHANNEL CARRIER	ITEM 6 HORIZONTAL ROD SEPARATOR
8.00"	02901501	02901401	02901301	02900101
10.00"	02901502	02901402	02901302	02900102
12.00"	02901503	02901403	02901303	02900103
14.00"	02901504	02901404	02901304	02900104
16.00"	02901505	02901405	02901305	02900105
18.00"	02901506	02901406	02901306	02900106
20.00"	02901507	02901407	02901307	02900107
22.00"	02901508	02901408	02901308	02900108
24.00"	02901509	02901409	02901309	02900109



GLEASON REEL CORP.
P.O. Box 26 • 600 South Clark St.
Mayville, WI 53050-0026
Phone 920-387-4120 • Fax 920-387-4189