

GLEASON® PowerTrak®

EF Type Model PT60EF-WH Parts List

ITEM	DESCRIPTION	PART NO.
1	Outer Link	P60E-99
2	Inner Link--11.00 radius	P60E-01
	" 14.81 radius	P60E-02
	" 20.50 radius	P60E-03
	" 24.12 radius	P60E-04
	" 29.50 radius	P60E-05
	" 36.00 radius	P60E-06
3	Anti-friction Plate	028922
4 - 6	-See Below-	
7	Socket Hd Cap Screw	051116
8	Flanged Bushing	051114
9	Washer	051115
10	Hex Locknut	028268
11	Shim Washer, .01 thick*	028915
12	Shim Washer, .02 thick*	028916
13	Skt. Hd. CSCR, M6-1.0 x 16	028920
14	Lockwasher, M6	028912
15	Mounting Bracket, L.H.	P07-345
16	Mounting Bracket, R.H.	P07-346

* Not required on all systems.

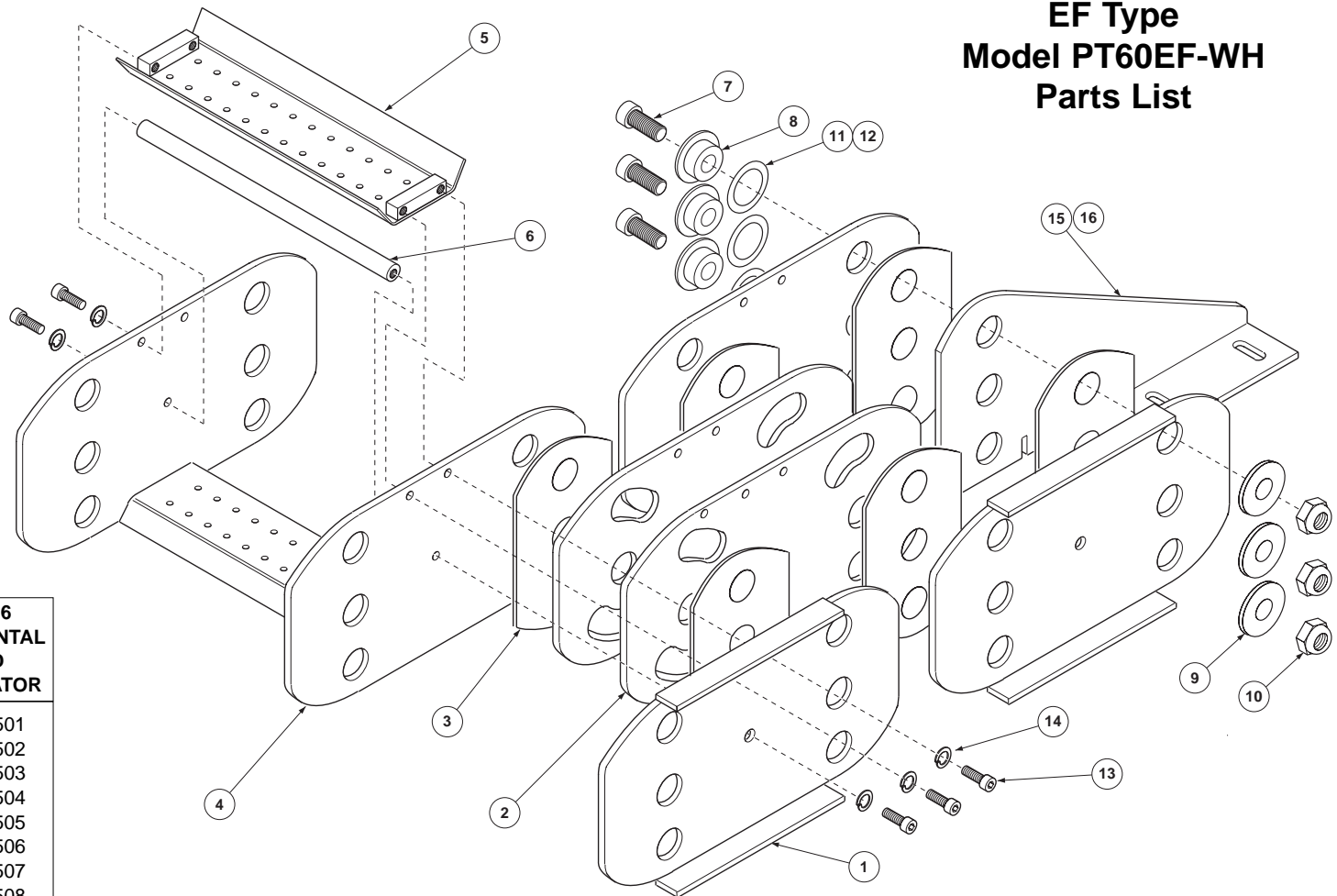

CARRIER WIDTH	ITEM 4 CHANNEL WELDMENT	ITEM 5 CHANNEL CARRIER	ITEM 6 HORIZONTAL ROD SEPARATOR
6.00"	02892301	02889501	02890501
8.00"	02892302	02889502	02890502
10.00"	02892303	02889503	02890503
12.00"	02892304	02889504	02890504
14.00"	02892305	02889505	02890505
16.00"	02892306	02889506	02890506
18.00"	02892307	02889507	02890507
20.00"	02892308	02889508	02890508
22.00"	02892309	02889509	02890509
24.00"	02892310	02889510	02890510



GLEASON REEL CORP.
P.O. Box 26 • 600 South Clark St.
Mayville, WI 53050-0026
Phone 920-387-4120 • Fax 920-387-4189