

GLEASON® PowerTrak

EF Type Model PT55EF-WV2 Parts List

ITEM	DESCRIPTION	PART NO.
1	Outer Link	P55E-99
2	Inner Link—11.22 radius	P55E-01
	" 15.00 radius	P55E-02
	" 18.69 radius	P55E-03
	" 24.31 radius	P55E-04
	" 30.00 radius	P55E-05
	" 36.00 radius	P55E-06
3	Anti-friction Plate	028054
4 & 5	—See Below—	
6	Socket Hd Cap Screw	051116
7	Flanged Bushing	051114
8	Washer	051115
9	Hex Locknut	028268
10	Shim Washer, .01 thick*	028915
11	Shim Washer, .02 thick*	028916
12	Skt. Hd. CSCR, M6-1.0 x 16	028920
13	Lockwasher, M6	028912
14	P55E Mounting Bracket, L.H.	P07-331
15	P55E Mounting Bracket, R.H.	P07-332
16	P55E Vertical Separating Rod	028909

* Not required on all systems.

CARRIER WIDTH	ITEM 4 CHANNEL WELDMENT	ITEM 5 CHANNEL CARRIER
6.00"	02890001	02889501
8.00"	02890002	02889502
10.00"	02890003	02889503
12.00"	02890004	02889504
14.00"	02890005	02889505
16.00"	02890006	02889506
18.00"	02890007	02889507
20.00"	02890008	02889508
22.00"	02890009	02889509
24.00"	02890010	02889510

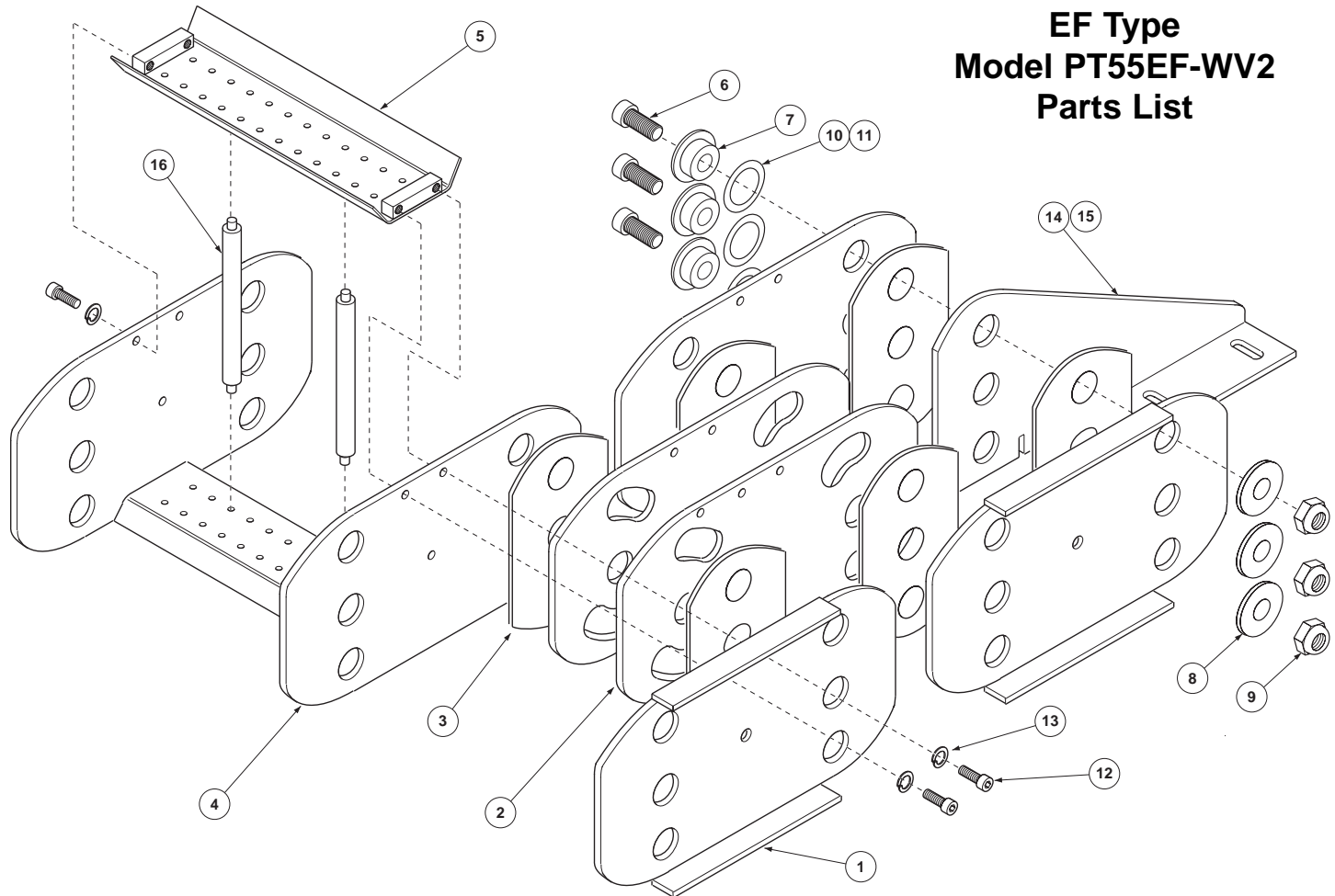

GLEASON REEL CORP.
P.O. Box 26 • 600 South Clark St.
Mayville, WI 53050-0026
Phone 920-387-4120 • Fax 920-387-4189