

GLEASON® PowerTrak®

EF Type Model PT55EF-NV2 Parts List

ITEM	DESCRIPTION	PART NO.
1	Outer Link	P55E-99
2	Inner Link—11.22 radius	P55E-01
	" 15.00 radius	P55E-02
	" 18.69 radius	P55E-03
	" 24.31 radius	P55E-04
	" 30.00 radius	P55E-05
	" 36.00 radius	P55E-06
3	Anti-friction Plate	028054
4 – 7	—See Below—	
8	Socket Hd Cap Screw	051116
9	Flanged Bushing	051114
10	Washer	051115
11	Hex Locknut	028268
12	Shim Washer, .01 thick*	028915
13	Shim Washer, .02 thick*	028916
14	Skt. Hd. CSCR, M6-1.0 x 16	028920
15	Lockwasher, M6	028912
16	Mounting Bracket, L.H.	P07-331
17	Mounting Bracket, R.H.	P07-332
18	Vertical Separating Rod	028909

* Not required on all systems.

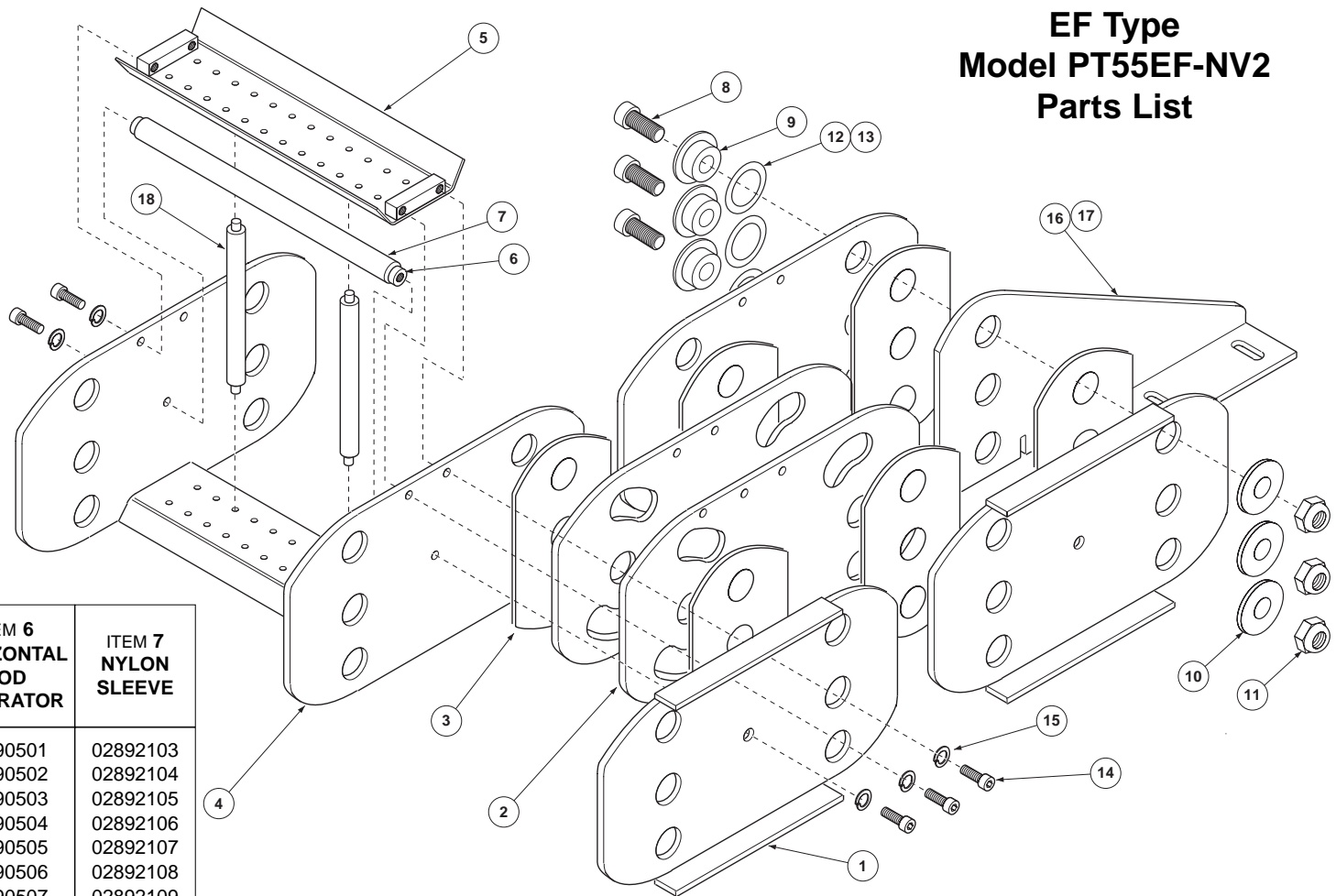

CARRIER WIDTH	ITEM 4 CHANNEL WELDMENT	ITEM 5 CHANNEL CARRIER	ITEM 6 HORIZONTAL ROD SEPARATOR	ITEM 7 NYLON SLEEVE
6.00"	02890001	02889501	02890501	02892103
8.00"	02890002	02889502	02890502	02892104
10.00"	02890003	02889503	02890503	02892105
12.00"	02890004	02889504	02890504	02892106
14.00"	02890005	02889505	02890505	02892107
16.00"	02890006	02889506	02890506	02892108
18.00"	02890007	02889507	02890507	02892109
20.00"	02890008	02889508	02890508	02892110
22.00"	02890009	02889509	02890509	02892111
24.00"	02890010	02889510	02890510	02892112



GLEASON REEL CORP.
P.O. Box 26 • 600 South Clark St.
Mayville, WI 53050-0026
Phone 920-387-4120 • Fax 920-387-4189