

GLEASON PowerTrak®

E-Type Model PT45E-TB Parts List

ITEM	DESCRIPTION	PART NO.
1	Outer Link	P01-124
2	Inner Link - 5.71 radius	P01-125
		7.50 radius
		11.22 radius
		15.00 radius
		24.31 radius
3	Anti-Friction Disc	025694
4	Hinge Pin	058506
5	E-Ring	102260
6	Alum. Channel - 4.00" lg.	02826501
		6.00" lg.
		8.00" lg.
		10.00" lg.
		12.00" lg.
		14.00" lg.
		16.00" lg.
7	Whiz-Lock Screw	106144
8	LH Mounting Bracket	P07-211
9	RH Mounting Bracket	P07-212
10	.25 Int Tooth Lockwasher	102602
11	.25-20 UNC Hex Nut	100942
12	Spacer Plate	045526
13	Retainer with Pem Stud	045525

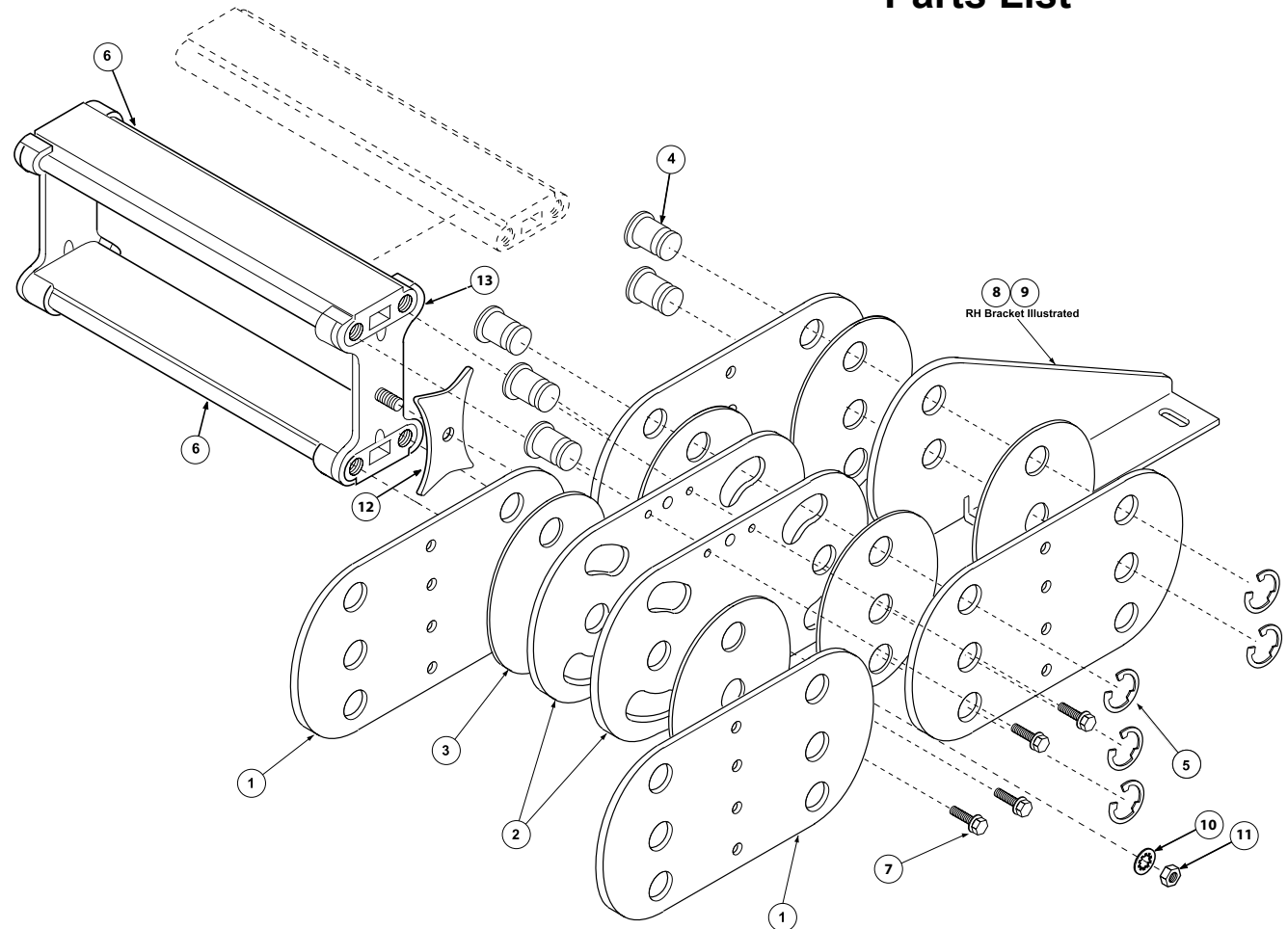

SIDE CHAIN ASSEMBLY (Includes items 1 - 5) Qty. 1 = one 1 ft. section for one side only. L.H. and R.H. chains are identical.	
RADIUS	PART NO.
5.71	09185401
7.50	09185402
11.22	09185403
15.00	09185404
24.31	09185405

PowerTrak Splice Kit P/N **034421** includes:
(6) hinge pins, (4) anti-friction discs, and
(12) E-ring fasteners



GLEASON REEL CORP.
600 South Clark St.
Mayville, WI 53050
Phone: 920-387-4120
Fax: 920-387-4189
www.hubbell-gleason.com