

GLEASON® PowerTrak

L Type Model PT36L-A1 Parts List

ITEM	DESCRIPTION	PART NO.
1	Outer Link	P300-00
2	Inner Link-5.00 radius	P300-01
	Inner Link-7.88 radius	P300-03
	Inner Link-11.38 radius	P300-04
	Inner Link-15.38 radius	P300-05
	Chain Splice Kit*	048690
4	Aluminum Channel-4.00" lg.	02705801
	Aluminum Channel-6.00" lg.	02705802
	Aluminum Channel-8.00" lg.	02705803
	Aluminum Channel-10.00" lg.	02705804
	Aluminum Channel-12.00" lg.	02705805
	Aluminum Channel-14.00" lg.	02705806
	Aluminum Channel-16.00" lg.	02705807
	Channel Separator	039686
5	Channel Separator	039686
6	Whiz-Lock Screw	106144
7	L.H. Mounting Bracket Kit <i>Includes Pins and E-Rings</i>	048674
8	R.H. Mounting Bracket Kit <i>Includes Pins and E-Rings</i>	048673

* Includes (6) pins and (6) E-rings. Used for splicing or repair. Original equipment has riveted construction.

SIDE CHAIN ASSEMBLY	
Includes items 1 and 2, riveted together to form length in feet specified, rounded up to next full link.	
Qty. 1 = one 1 ft. section for one side only.	
L.H. and R.H. chains identical.	
RADIUS	PART NO.
5.00	04891301
7.88	04891302
11.38	04891303
15.38	04891304

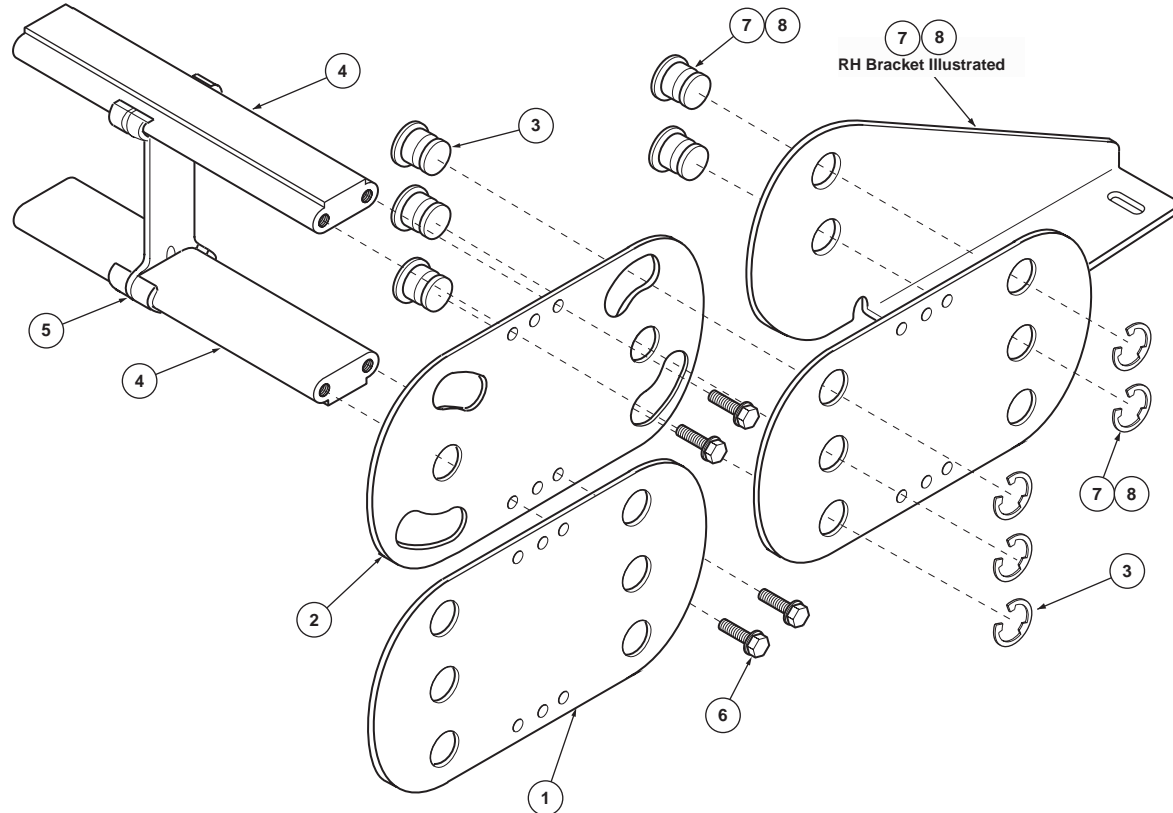

GLEASON REEL CORP.
P.O. Box 26 • 600 South Clark St.
Mayville, WI 53050-0026
Phone 920-387-4120 • Fax 920-387-4189