

E-Type Model PT28E-T1 Parts List

ITEM	DESCRIPTION	PART NO.
1	Outer Link	P28E-00
2	Inner Link - 2.95 radius	P28E-01
	3.74 radius	P28E-02
	4.53 radius	P28E-03
	5.31 radius	P28E-04
	6.10 radius	P28E-05
	7.87 radius	P28E-06
3	Anti-Friction Disc	026727
4	Hinge Pin	058503
5	E-Ring	102261
6	Alum. Channel - 4.00" lg.	02705701
	6.00" lg.	02705702
	8.00" lg.	02705703
	10.00" lg.	02705704
	12.00" lg.	02705705
	7	Whiz-Lock Screw
8	LH Mounting Bracket	P07-219
9	RH Mounting Bracket	P07-220
10	#10 Int Tooth Lockwasher	022453
11	#10-32 UNC Hex Nut	100938
12	Spacer Plate	045555
13	Retainer with Pem Stud	045557
14	Channel Separator	036270

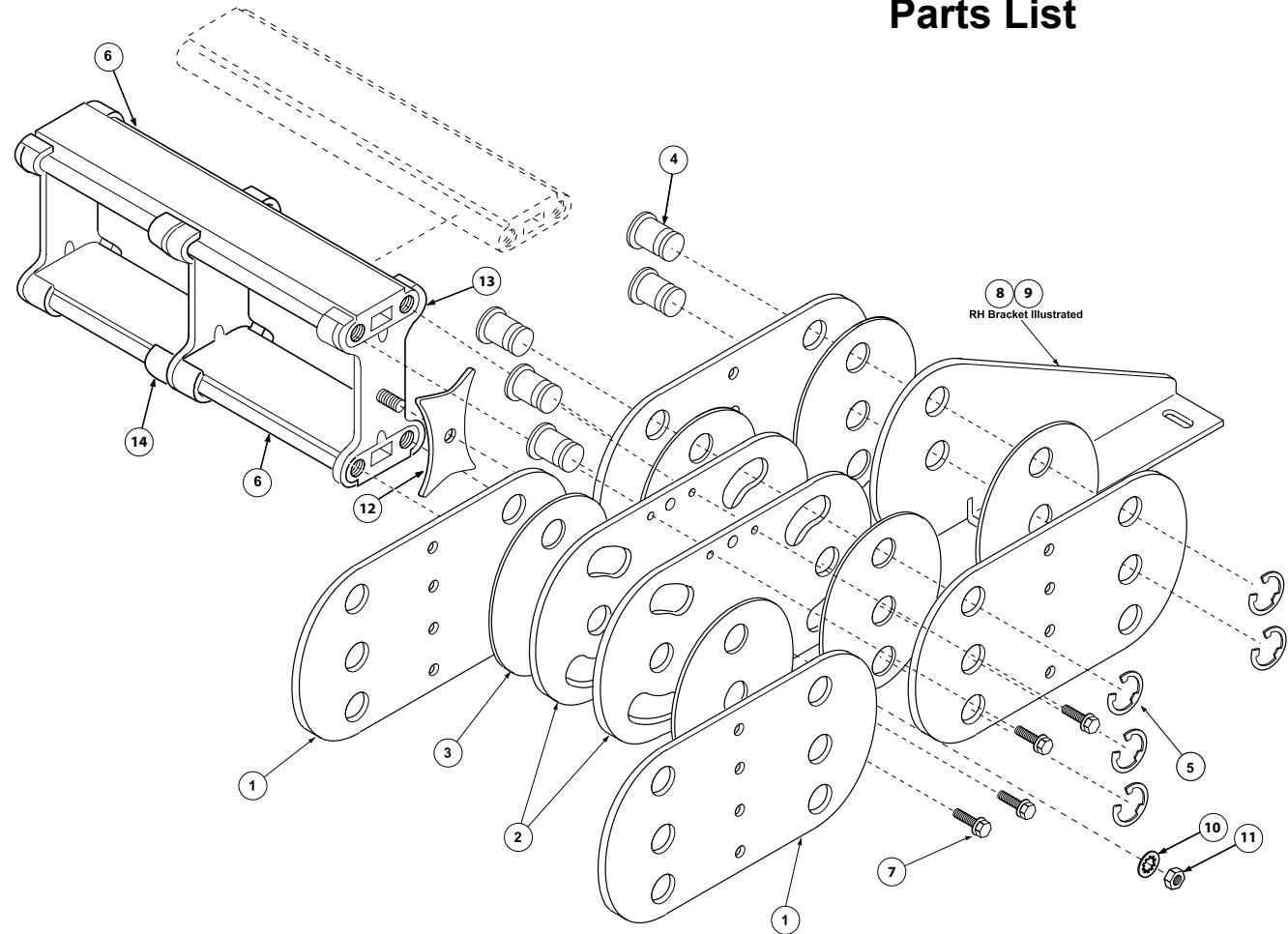

SIDE CHAIN ASSEMBLY

(Includes items 1 - 5)

Qty. 1 = one 1 ft. section

for one side only.

L.H. and R.H. chains are identical.

RADIUS	PART NO.
2.95	09185201
3.74	09185202
4.53	09185203
5.31	09185204
6.10	09185205
7.87	09198506

PowerTrak Splice Kit P/N **034418** includes:
(6) hinge pins, (4) anti-friction discs, and
(12) E-ring fasteners



GLEASON REEL CORP.

600 South Clark St.
Mayville, WI 53050
Phone: 920-387-4120
Fax: 920-387-4189
www.hubbell-gleason.com