

GLEASON® PowerTrak

L Type Model PT26L-R1* Parts List

ITEM	DESCRIPTION	PART NO.
1	Outer Link	041627
2	Inner Link-2.75 radius	04162801
	Inner Link-4.53 radius	04162802
	Inner Link-5.63 radius	04162803
3	PT26L Splice Kit*	044792
4	Aluminum Rod-4.00" lg.	04344802
	" 6.00" lg.	04344803
	" 8.00" lg.	04344804
	" 10.00" lg.	04344805
	" 12.00" lg.	04344806
5	Rod Separator	027476
6	Pan Head Locking Screw	047389
7	L.H. Mounting Bracket Kit <i>Includes Pins and E-Rings</i>	043384
8	R.H. Mounting Bracket Kit <i>Includes Pins and E-Rings</i>	043383

* Includes (6) pins and (6) E-rings. Used for splicing or repair. Original equipment has riveted construction.

SIDE CHAIN ASSEMBLY	
Includes items 1 and 2, riveted together to form length in feet specified, rounded up to next full link.	
Qty. 1 = one 1 ft. section for one side only.	
L.H. and R.H. chains identical.	
RADIUS	PART NO.
2.75	04345401
4.53	04345402
5.63	04345403

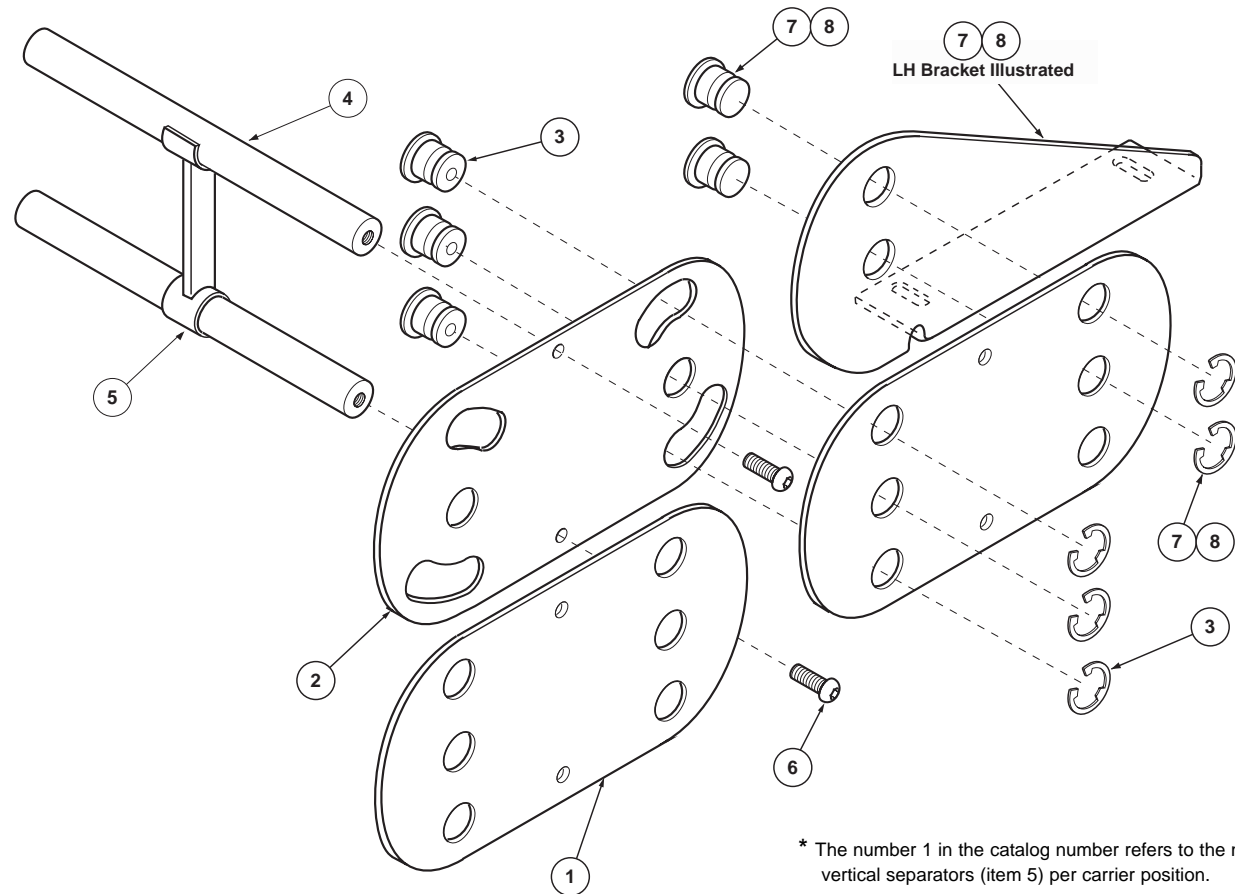

* The number 1 in the catalog number refers to the number of vertical separators (item 5) per carrier position.



GLEASON REEL CORP.
P.O. Box 26 • 600 South Clark St.
Mayville, WI 53050-0026
Phone 920-387-4120 • Fax 920-387-4189