

GLEASON® PowerTrak

EF Type Model PT100EF-HV2 Parts List

ITEM	DESCRIPTION	PART NO.
1	Outer Link	P100E-99
2	Inner Link—19.00 radius	P100E-01
	" 25.00 radius	P100E-02
3	Anti-friction Plate	029012
4-6	—See Below—	
7	Socket Head Cap Screw	029227
8	Flanged Bushing	048977
9	Washer	042910
10	Hex Locknut	028502
11	Shim Washer, 1.53 ID x .01 thick*	029024
12	Shim Washer, 1.53 ID x .02 thick*	029025
13	Skt. Hd. CSCR, M8-1.25 x 20	029020
14	Lockwasher, M8	023279
15	Mounting Bracket, L.H.	P07-349
16	Mounting Bracket, R.H.	P07-350
17	Vertical Separating Rod	029005

* Not required on all systems.

CARRIER WIDTH	ITEM 4 CHANNEL WELDMENT	ITEM 5 CHANNEL CARRIER	ITEM 6 HORIZONTAL ROD SEPARATOR
8.00"	02901001	02901301	02900101
10.00"	02901002	02901302	02900102
12.00"	02901003	02901303	02900103
14.00"	02901004	02901304	02900104
16.00"	02901005	02901305	02900105
18.00"	02901006	02901306	02900106
20.00"	02901007	02901307	02900107
22.00"	02901008	02901308	02900108
24.00"	02901009	02901309	02900109

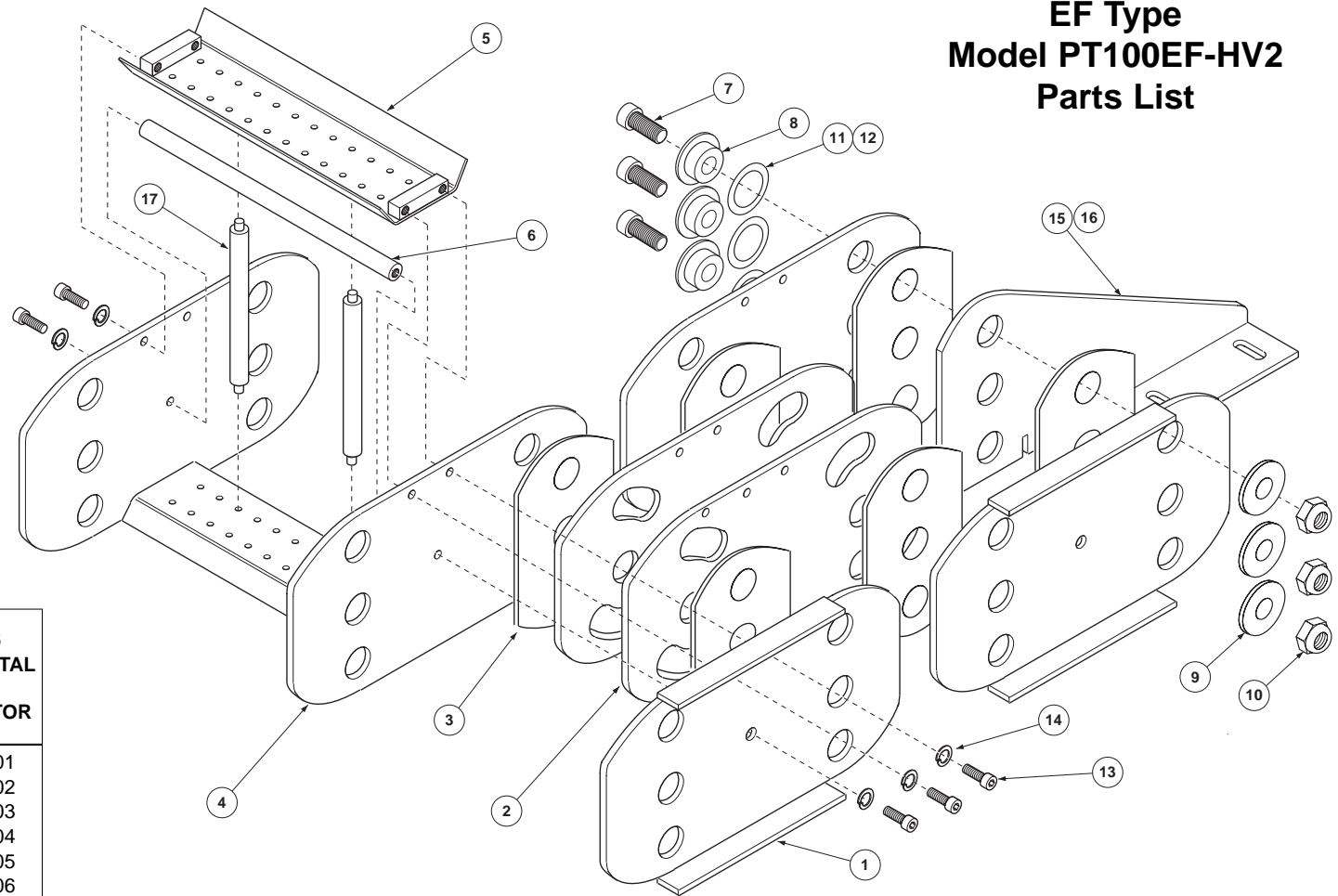

GLEASON REEL CORP.
P.O. Box 26 • 600 South Clark St.
Mayville, WI 53050-0026
Phone 920-387-4120 • Fax 920-387-4189