

# GLEASON® PowerTrak®

## E Type Model PT100E-HV2 Parts List

ITEM	DESCRIPTION	PART NO.
1	Outer Link	P100E-98
2	Inner Link—19.00 radius	P100E-01
	" 25.00 radius	P100E-02
3	Anti-friction Plate	029012
4-6	—See Below—	
7	Hinge Pin	P04-76
8	Retaining Ring	700056
9	Shim Washer, 1.53 ID x .01 thick	029024
10	Shim Washer, 1.53 ID x .02 thick	029025
11	Skt. Hd. CSCR, M8-125 x 20	029020
12	Lockwasher, M8	023279
13	Mounting Bracket, L.H.	P07-349
14	Mounting Bracket, R.H.	P07-350
15	Vertical Separating Rod	029005

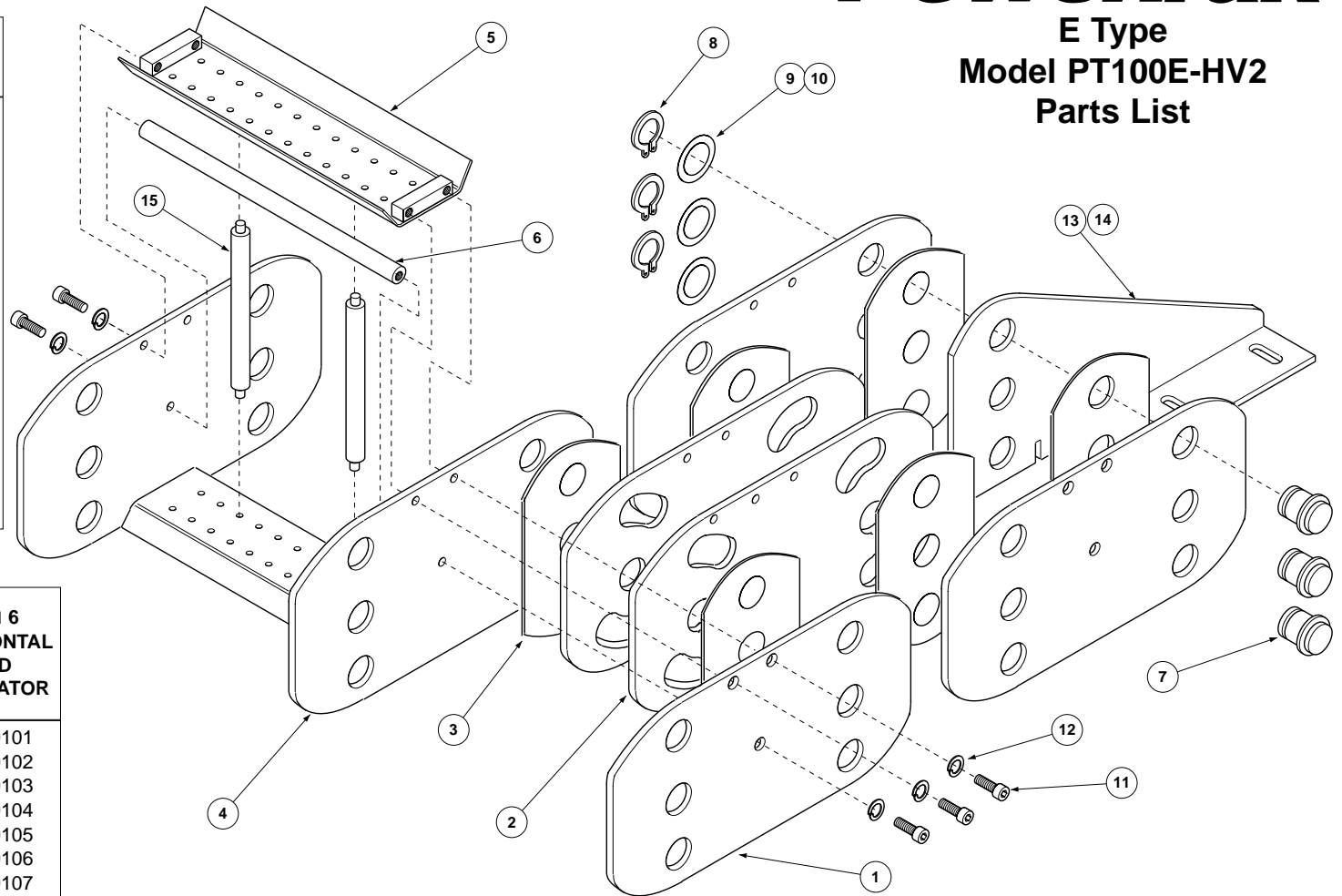

CARRIER WIDTH	ITEM 4 CHANNEL WELDMENT	ITEM 5 CHANNEL CARRIER	ITEM 6 HORIZONTAL ROD SEPARATOR
8.00"	02901001	02901301	02900101
10.00"	02901002	02901302	02900102
12.00"	02901003	02901303	02900103
14.00"	02901004	02901304	02900104
16.00"	02901005	02901305	02900105
18.00"	02901006	02901306	02900106
20.00"	02901007	02901307	02900107
22.00"	02901008	02901308	02900108
24.00"	02901009	02901309	02900109



**GLEASON REEL CORP.**  
P.O. Box 26 • 600 South Clark St.  
Mayville, WI 53050-0026  
Phone 920-387-4120 • Fax 920-387-4189