

# INSTALLATION and MAINTENANCE INSTRUCTIONS

## 14" & 19" SPRING OPERATED HOSE REELS

With Old Dog & Ratchet Design, Mfg. Before 1-1-10



**NOTE:** These instructions are written for machine pull reels.

If installing or servicing hand pull reel, use only those steps marked with hand .

All units are provided with right hand rotation unless otherwise specified. This means that hose rotates **clockwise** to wind hose when viewing reel from **spring** (inlet) **side**...opposite when viewed from swivel joint (spooled hose connection) side.

Clock-type springs provide power for hose take-up. **Spring must be pretensioned at time of installation** to insure that tension is applied to hose at all times.

### INSTALLATION

1. If hose is to be coupled to a machine, insure that machinery is at position closest to reel.

2. Securely mount reel in desired position using 3/8"(M10) bolts. Be sure spool centerline is aligned with hose run.

**NOTE: E-Z PULL reel should be mounted 3' maximum above floor. Reel will not "LIFT" hose overhead.**

### CAUTION

If mounting overhead, provide safety chain between reel base and mounting surface to prevent potential reel drop.

3. Position hose guide. Guide must be oriented so hose pays off reel in a straight line without bends. **If E-Z PULL, hose should pay-out horizontally.**
4. Remove hose stop, if attached to hose. Rotate spool counter-clockwise (when viewed from swivel joint side) until all hose is wound on reel...not extending through hose guide. See Figure 1.

Figure 1

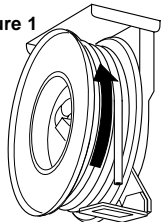

WIND ALL HOSE ONTO SPOOL

Figure 2

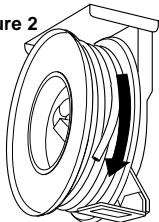

PRE-TENSION-ROTATE SPOOL 360° TURNS IN LAST TWO DIGITS OF MODEL NUMBER ON SERIAL PLATE

5. Pre-tension reel by rotating spool in clockwise direction (when viewed from swivel joint side). Full 360° turns should match last digit in model number on serial plate.
6. Engage ratchet lock to prevent spool from unwinding.
7. Feed hose end out through hose guide and pay-out hose to maximum working length. At least one turn of hose should remain on spool. If spool locks up prior to reaching required length, either reel was over-tensioned during step 5 or reel capacity has been exceeded. Failure to correct this condition will result in shortened spring life and possible damage to other reel components.
8. Attach hose stop and adjust free length of hose. Connect hose to machine or add attachments.
9. If machine pull application or if no-lock operation is desired, disengage ratchet lock. See following section.
10. Connect supply hose to fitting on spring side of reel.
11. Turn on pressure to reel. Test for leaks.

### RATCHET LOCK

Reel is shipped with ratchet lock "engaged". If constant spring tension is required, lock may be disengaged by locating and removing the selector plate anchor screw on the frame, rotating the selector plate to disengage position, and replacing and tightening the selector plate screw.

### MAINTENANCE

Bearings and springs are prelubricated and require no periodic maintenance.

### WARNING

Do not attempt to remove spring from its housing. Clock-type springs can be dangerous to handle. Removal of spring from housing could result in personal injury.

### SPRING REPLACEMENT

The unique SAFETYCHANGE® spring motor consists of a spring sealed within a housing. A replacement spring is supplied sealed in its housing and the old unit should be discarded completely.

1. Turn off supply pressure to reel.
2. Disconnect hose from machine or remove attachments.
3. Wind hose onto reel to relieve **all** spring tension.
4. Using a 3/16" allen wrench, loosen socket head screw in main shaft clamp nut. Support spool and spin nut off shaft.
5. Remove entire spool and spring motor assembly from frame.
6. Remove V-Ring seal from spring assembly.
7. Remove nuts holding spring assembly and slide spring assembly off main shaft.
8. Slide new spring assembly onto shaft and reassemble reel by reversing above steps.
9. Adjust spring tension. Refer to SPRING ADJUSTMENT.

### CAUTION

Failure to relieve all spring tension prior to removing hose could result in damage to equipment or personal injury. Follow instructions carefully.

### HOSE REMOVAL

Use the following procedure to remove worn or damaged hose from reel prior to installation of new hose.

1. Move machine serviced by reel to a position closest to reel. Spring will still be under pre-tension at this point.
2. Turn off supply pressure to reel.
3. Disconnect hose from machine or other attachments. Remove hose stop and allow hose to retract onto spool. Ensure all tension is off spring by manually

CONTINUED ON BACK PAGE 

## 14" & 19" DIRECT DRIVE HOSE REEL REPLACEMENT PARTS LIST

ITEM	KIT NO.	DESCRIPTION	QTY.
1	032631	Frame Assembly, 14" Reel	1
1	032632	Frame Assembly, 19" Reel	1
2	021484	Clamp Nut	1
3	025032	V-Ring Seal	1
4	604093	Locking Dog Repair Kit (Includes mounting hardware)	1
5	028132	Hex Head Capscrew, M10 x 25L	3
6	028138	Lockwasher, M10	3
7	021527	Mount Bracket, 14" Reel	1
7	023417	Mount Bracket, 19" Reel	1
8	024466	Roller Guide Assembly, 14" Reel	1
8	024473	Roller Guide Assembly, 19" Reel	1
9	028144	Lock Nut, M5 x 0.8, 14" Reel	6
9	028144	Lock Nut, M5 x 0.8, 19" Reel	8
10	05059801	Spring Assembly "1", 14" Reel	1
10	05059802	Spring Assembly "2", 14" Reel	1
10	05059803	Spring Assembly "3", 14" Reel	1
10	05059804	Spring Assembly "4", 19" Reel	1
10	05059806	Spring Assembly "5", 19" Reel	1
10	05059809	Spring Assembly "7", 19" Reel	1
10	05059810	Spring Assembly "8", 19" Reel	1
11	021494	Spring Gasket, 14" Reel	1
11	022734	Spring Gasket, 19" Reel	1
12	027485	Shaft, 14" Reel	1
12	027487	Shaft, 19" Reel	1
13	024294	Spool Assembly, 14" Reel	1
13	024297	Spool Assembly, 19" Reel	1

ITEM	KIT NO.	DESCRIPTION	QTY.
14	027444	Flange Bushing, 14" Reel	1
14	027409	Flange Bushing, 19" Reel	1
15	028144	Lock Nut, M5 x 0.8	4
16	107185	Retaining Ring, 14" Reel	1
16	027406	Retaining Ring, 14" Reel	1
17	604123	Swivel Joint, 14" Reel with 1/4" & 3/8" hose	1
17	024513	Swivel Joint, 14" Reel with 1/2" hose & all 19" Reels	1
18	024521	Hose Barb-4, 14" Reel	1
18	024497	Hose Barb-6, 14" Reel	1
18	024517	Hose Barb-4, 19" Reel	1
18	024515	Hose Barb-6, 19" Reel	1
18	101539	Hose Barb-8, 19" Reel	1
19	604127	Tubing Clamp-1/4" hose	1
19	604128	Tubing Clamp-3/8" hose	1
19	604129	Tubing Clamp-1/2" hose	1
20	103281	5/16 x 3/4 Soc. Hd. Cap Screw	2
21	101206	Flat Washer, 1/4"	2
22	023304	Lock Nut, 5/16	2
23	024516	Bushing, 14" Reel	1
23	024519	Bushing, 19"-4 Reel Only	1
24	027456	Thrust Washer, 14" Reel	1
25	024514	Street Elbow, 19" Reel	1
26	024516	Bushing, 14" Reel	1
26	024519	Bushing, 19"-6 Reel	1
26	024520	Bushing, 19"-4 Reel	1
<b>OPTIONAL ACCESSORIES</b>			
	022451	Hose Stop, 14" & 19" -4 &-6 Reels	Option
	022452	Hose Stop, 19"-8 Reel	Option
	022217	Swivel Base, 14" Reel	Option
	022220	Swivel Base, 19" Reel	Option

Always specify **SERIAL NUMBER & MODEL NUMBER**  
when ordering parts.

14" & 19" DIRECT DRIVE HOSE REEL

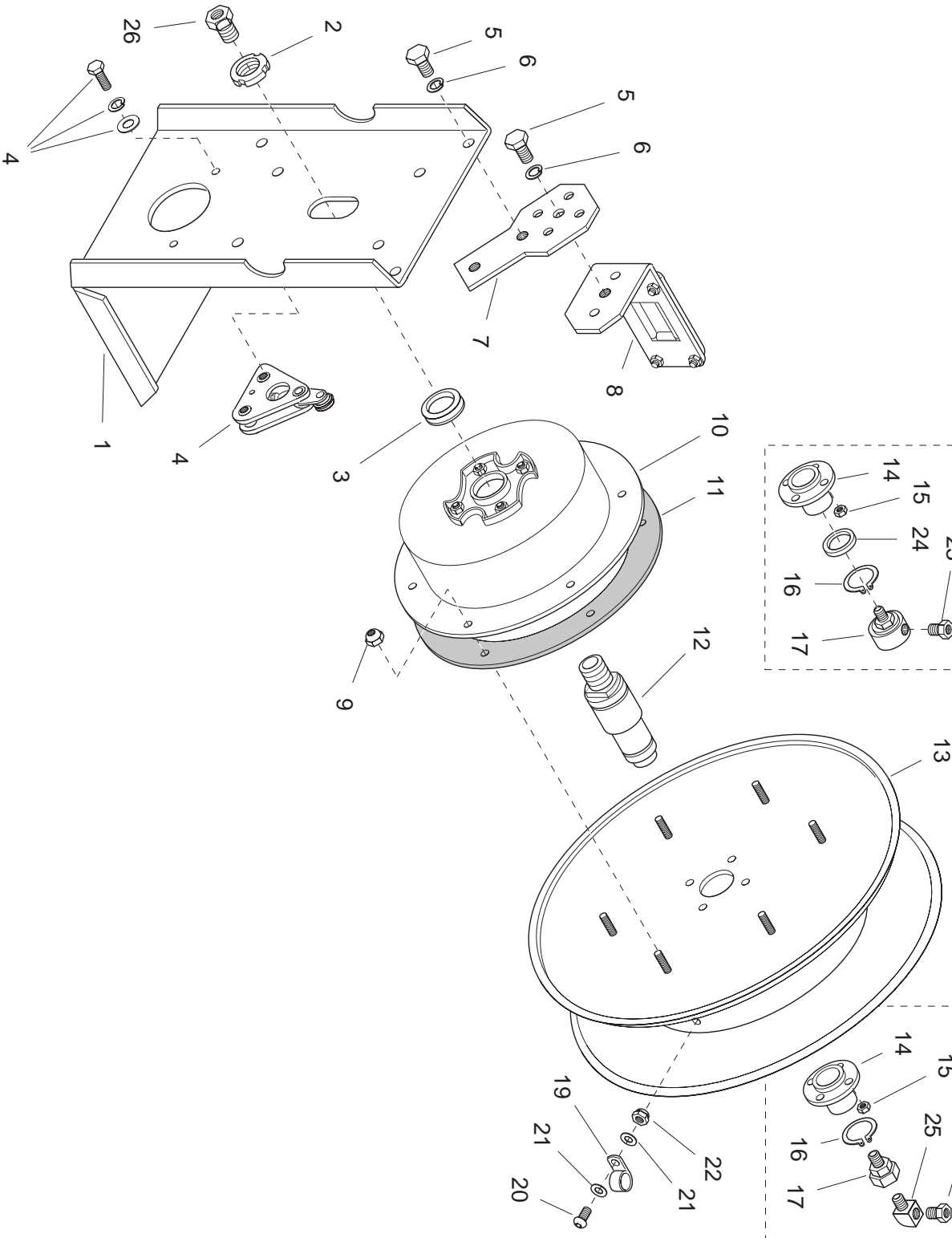

rotating spool (normally clockwise when viewed from spring side).

4. Remove hose from spool by looping over spool flange.
5. Remove tube clamp from spool.
6. Loosen hose clamp affixing hose to hose barb on swivel joint fitting located on inside of spool.
7. Pull hose out of hole in spool.
8. Slide tube clamp off hose.
8. Install new hose following directions below.

### HOSE INSTALLATION

Use the following procedure to replace hose or if reel was ordered without hose. Refer to HOSE INSTALLATION REFERENCE DRAWING, below.

1. Unspool new hose from shipping spool and lay out to eliminate twist.

NOTE: This step is not essential, but will aid in winding operation of the reel and prolong hose life.

2. Remove tube clamp from spool and slide onto hose. Be sure tube clamp is orientated so that loop on clamp will be next to outside spool flange. (See drawing below.)
3. Feed bare end of hose through hole in spool hub and connect to hose barb on swivel joint fitting. Secure with hose clamp. (See drawing below.)
4. Align tube clamp on hose with hole in spool hub. Fasten with socket head screw, washers and nut.
5. Wind the hose onto the reel spool by hand rotating spool in direction it turns free of spring tension. (Normally clockwise when viewed from spring side)
6. Adjust hose stop (not used on machine pull reel).
7. Complete working end connections.

8. Pretension reel and complete installation as described in INSTALLATION section.

### SPRING ADJUSTMENT

Adjust tension by adding wraps (increasing tension) or removing wraps (decreasing tension) from the spool.

#### ⚠ WARNING

If machine pull reel, move machinery to position closest to reel before adjusting spring tension. Adjusting tension with hose extended may result in damage to reel or personal injury.

1. Pull about 10' of hose, allowing spool to rotate.

**INCREASE TENSION:** Without allowing spool to rotate, hand feed hose back through hose guide until loop is large enough to slip onto spool. **Add** two or three wraps until desired tension is achieved. See Figure 3.

**DECREASE TENSION:** Without allowing spool to rotate, hand feed hose back through guide to provide slack. **Remove** one or two wraps from spool. See Figure 4.

2. Test reel operation.

DO NOT ALLOW SPOOL TO ROTATE WHILE ADDING OR REMOVING WRAPS.

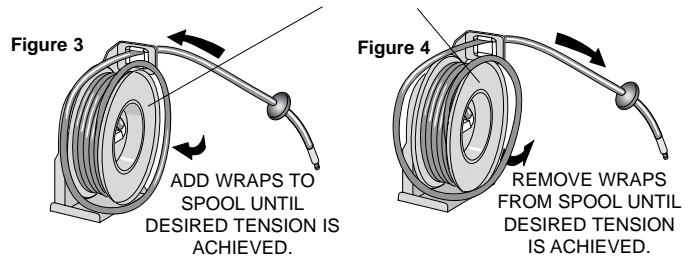

### HOSE INSTALLATION REFERENCE DRAWING

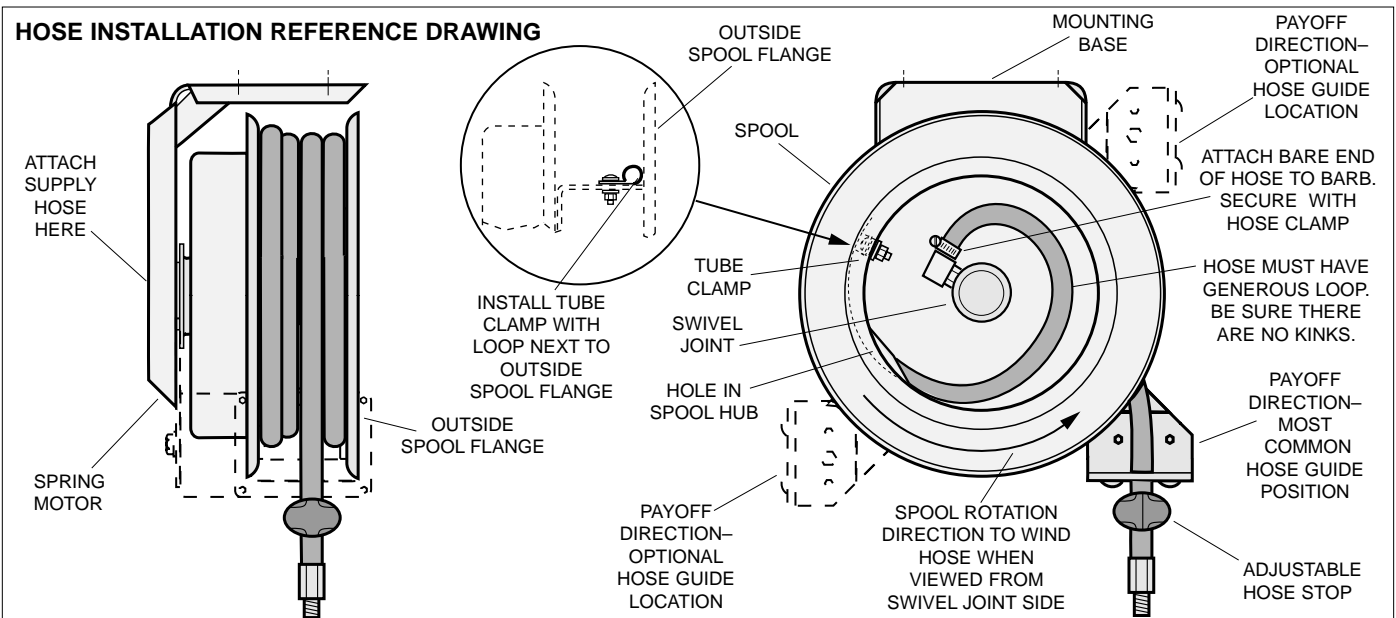

**GLEASON REEL CORP.**  
P.O. Box 26 • 600 South Clark St.  
Mayville, WI 53050-0026  
Phone 920-387-4120  
Fax 920-387-4189