



Workplace Solutions

## POWER-UP...AND PUT SOME LIGHT ON THE SUBJECT

Here are fitting touches to your workplace...a fluorescent, overhead work light and a power bar. Both are custom designed for use on Workplace Solutions workstations. Three **Work Lights** are available. One has adjustable mounting brackets and two 48" fluorescent T8 lamps (included). The two others have fixed brackets...one includes four 48" tubes, the other four 24" tubes. **Power Bar** is available in two lengths; 36" with six grounded outlets and 60" with ten outlets. Power Bar features on/off switch, circuit breaker with reset button and mounting bar. Order mounting bar to fit width of your workstation. Mounting hardware is included. Lights include 10' cord and power bar includes 6' cord with standard 110v AC grounded plugs.

DESCRIPTION	MODEL NUMBER	FC* @ 3'	FC* @ 4'
48" Two Tube Adjustable Workstation Light	WBL-204A	93	70
48" Four Tube Fixed Workstation Light	WBL-404	185	130
24" Four Tube Fixed Workstation Light	WBL-402	110	77
"Z" Bracket to raise light flush with supports	WBL-40X-AM	na	na
36" Power Bar with 36" Mounting Bar	WPB-303A	na	na
36" Power Bar with 48" Mounting Bar	WPB-304A	na	na
36" Power Bar with 60" Mounting Bar	WPB-305A	na	na
36" Power Bar with 72" Mounting Bar	WPB-306A	na </td <td>na</td>	na
60" Power Bar with 60" Mounting Bar	WPB-505A	na	na
60" Power Bar with 72" Mounting Bar	WPB-506A	na	na

### WORK LIGHTS FEATURE:

- Parabolic louver. Directs light toward work area, not eyes.
- Accepts T8 fluorescent lamps.
- Polycarbonate safety tubes. Protect lamps, increase safety and meet OSHA, FDA, NEC and USDA requirements preventing contamination in case of lamp breakage.
- Model WBL-204A tilts 15° fore or aft and adjusts to bench width.
- Blacked-out side lens minimizes stray light.

### POWER BARS FEATURE:

- Grounded outlets and plugs.
- On/off switch and circuit breaker with reset.
- Mounting bracket and hardware in length to fit your work bench.

\* One foot-candle is equal to one lumen per square foot.

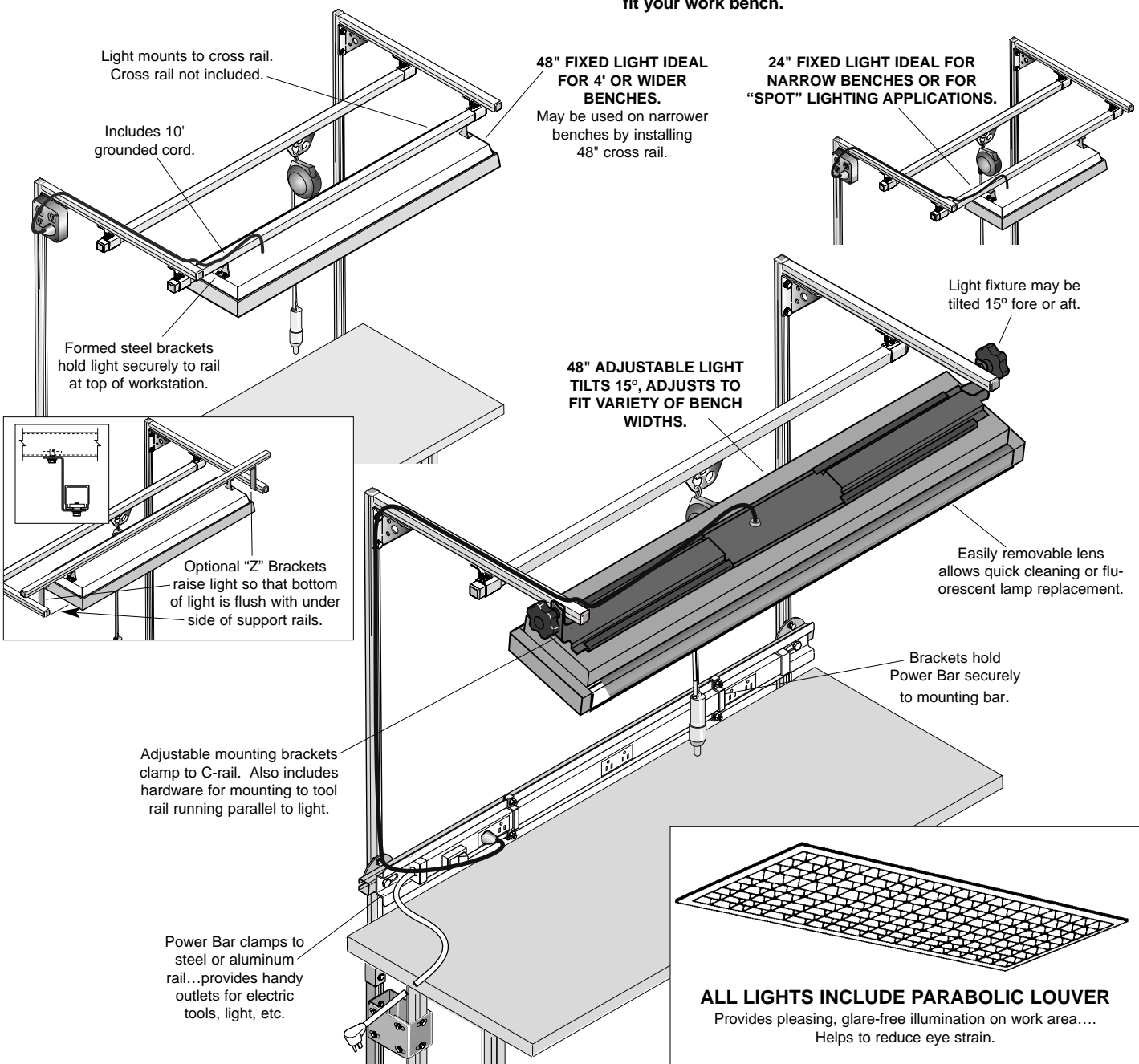

# ACCESSORIES

HUBBELL

Workplace Solutions

# ADD ACCESSORIES TO YOUR KIT MAKE YOUR WORKSTATIONS DO ALL THEY CAN DO

## MANIFOLD WITH BRACKETS

### NEW DESIGN

Square tubing provides 66% more volume than former round tube. Ideal where multiple tools are used. Drilled and tapped for 3/8" NPT air inlets and outlets (see chart below for quantity). Mounts to vertical columns or top rails on workstations. Beige Polyester Finish. Mounting hardware included.

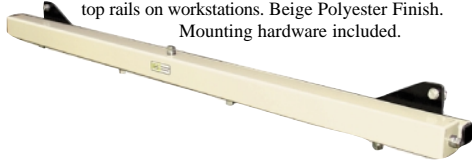

WIDTH ft. (m)	No. TAPS	SHIPPING WEIGHT	MODEL NUMBER
3.0 (0.9)	3	18 lbs.	WMAN-03C
4.0 (1.2)	4	22 lbs.	WMAN-04C
5.0 (1.5)	5	28 lbs.	WMAN-05C
6.0 (1.8)	6	33 lbs.	WMAN-06C
7.0 (2.1)	7	37 lbs.	WMAN-07C
8.0 (2.4)	8	42 lbs.	WMAN-08C

## BIN BAR WITH BRACKETS

Holds hanging plastic bins. Mounts to WS50 or WA50 vertical columns. Beige Polyester Finish. Includes mounting brackets and hardware. Accepts Akro, Lewis, Nestier, Duralene and other brands of bin boxes. Maximum capacity 50 lbs.(22.5kg).

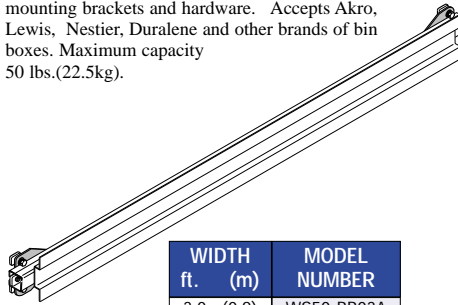

WIDTH ft. (m)	MODEL NUMBER
3.0 (0.9)	WS50-BB03A
4.0 (1.2)	WS50-BB04A
5.0 (1.5)	WS50-BB05A
6.0 (1.8)	WS50-BB06A
7.0 (2.1)	WS50-BB07A
8.0 (2.4)	WS50-BB08A
9.0 (2.7)	WS50-BB09A

## SHELVES WITH BRACKETS

Hold up to 50 lbs.(22.5 kg). of parts, tools, etc. Adjustable tilt. Style "A", in 12" or 18" depth, mounts between vertical columns (column spacing fixed). Style "B" (12" deep only) mounts on front of columns (brackets may be adjusted to match column spacing). Polyester Finish. Shelves beige, brackets black. Mounting hardware included.

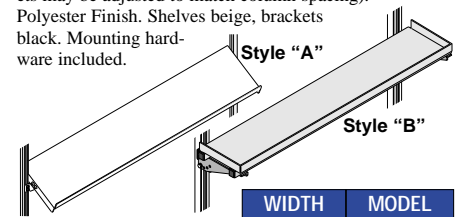

WIDTH* in. (mm)	MODEL NUMBER	WIDTH in. (mm)	MODEL NUMBER
Style "A"-12"(305) Deep		Style "B"-12"(305) Deep	
30.0 (762)	WS50-SS03	30.0 (812)	WS50-SS03A
42.0 (1067)	WS50-SS04	42.0 (1117)	WS50-SS04A
54.0 (1372)	WS50-SS05	54.0 (1422)	WS50-SS05A
66.0 (1676)	WS50-SS06	66.0 (1727)	WS50-SS06A
Style "A"-18"(457) Deep		Brackets Only (Set Of 2)	WS50-SS00A
30.0 (762)	WS50-SS183		
42.0 (1067)	WS50-SS184		
54.0 (1372)	WS50-SS185		
66.0 (1676)	WS50-SS186		

\*Center-to-center spacing of vertical columns must be WIDTH + 2" (51mm) for Style "A" shelves.

# ADJUSTABLE FOOT REST

## EASY ON THE LEGS

Seated or standing, your workers can be more productive and more comfortable when a foot rest is used. In addition, use of a foot rest offers a degree of protection from back or leg strain. Fully adjustable and strong enough for heavy industrial applications, it's constructed of steel with extruded aluminum foot bar. Standard model measures 29" wide, 12.75" deep and 12.25" high. Smaller "under desk" version measures is 23" wide. Both rest on four non-skid rubber feet. The foot bar is easily adjustable from 4" to 11" above the floor and tilts 15° fore and aft. Frame is finished with matte black baked polyester coating. Foot bar is natural aluminum with two anti-skid strips.

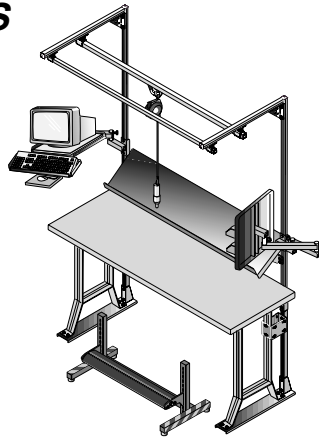

DESCRIPTION	MODEL NUMBER
Standard Adjustable foot rest	HWS-FR01
Office "under desk" foot rest	HWS-FR02

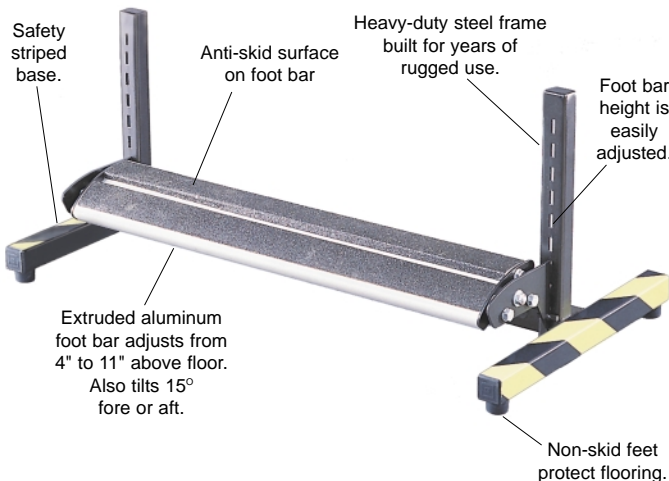

# AIR LINES

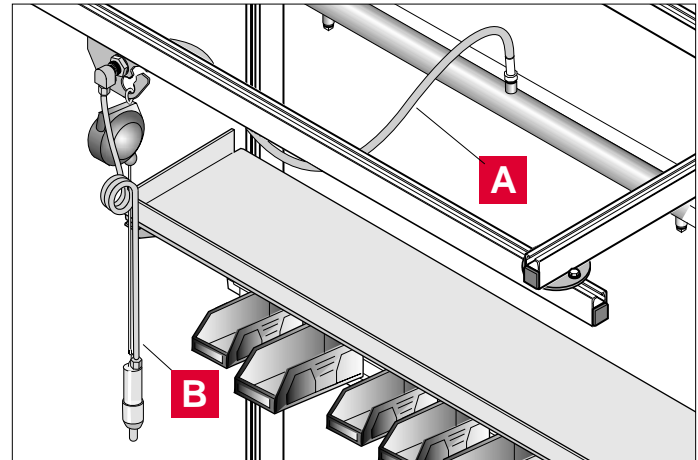

**A** The most flexible air line we have found. Ideal for connecting tool trolley to manifold or other supply because its flexibility does not interfere with trolley movement. Clear, reinforced plastic, 3/8" I.D. with 3/8" NPT male swivel fittings on both ends.

LENGTH ft. (m)	MODEL NUMBER
2 (0.6)	HWS-AL02
3 (0.9)	HWS-AL03
4 (1.2)	HWS-AL04
5 (1.5)	HWS-AL05
6 (1.8)	HWS-AL06

**B** Coiled hose from trolley to tool. Transparent blue polyurethane hose is flexible and light weight, doesn't interfere with tool positioning. Excellent memory retention. High chemical resistance. 3/8" O.D. x 1/4" I.D. x 4' extended length. 1/4" NPT male swivel fitting both ends.

MODEL NUMBER
HWS-AC04