

GLEASON REEL CORP.

Hubbell Workplace Solutions

SAFETY, ERGONOMICS & EFFICIENCY



Workplace Solutions



FEATURING
Qualtech[™]



Made in U.S.A.

www.hubbell-geason.com

HWS 0915

Don't let your work area be a possible OSHA violation!



Retrofit your existing workbench.



EASILY ASSEMBLED KITS, COMPONENTS and ACCESSORIES
See page 4 for details.

TABLE of CONTENTS

Description	Page	Description	Page	Description	Page
"Ergonomics Pays Dividends".....	3	JIBS		Qualtech	
WORKSTATION KITS & ACCESSORIES		Bench Mounted Kits.....	20	WORKSTANDS	
"Update Your Workbenches".....	4	Floor Mounted Kits.....	20-22	Document Stands.....	31
Single Column Kits.....	5	Ceiling Mounted Kits.....	23	Information Stands.....	31
Dual Column, Straight Tool Rail Kits.....	6	Retrievers.....	24	Message Board Stands.....	31
Curved Rail System Components.....	7	Packaging Station Kit.....	24	Catalog Display Stands.....	32
Balancers 0.5 to 23 lbs.....	8	MOBILE KITS		Inspection Stands.....	32
Retractors 3 to 23 lbs.....	8	Shelf Cart Kits & Components.....	25	Blueprint Display Stands.....	32
Torque Reels 3 to 15 lbs.....	8	Rolling Bin Rack.....	25	Parts Caddy.....	32
BD and BG Balancer Accessories.....	8	Gravity Feed Rack.....	25	Kaizen Event Display Stand.....	33
Balancers 9 to 308 lbs.....	9	Gravity Feed Cart.....	25		
BH Balancer Accessories.....	10	Portable Workstation Kit.....	26		
BA Air Tool Balancer Accessories.....	11	Mobile Wire Spool Cart.....	26		
Lights & Power Bars.....	12	Mobile Test Station.....	26		
Workstation Kit Accessories.....	13	COMPONENTS			
Adjustable Foot Rest.....	13	Aluminum Track.....	27		
Air Lines.....	13	Steel Track, 30 lb. capacity.....	28		
Swing Arms and Accessories.....	14-15	Steel Track, 50 lb. capacity.....	29		
Ergonomic TORQ-ARMS™.....	16	Booms, Mounting Bases.....	30		
Ergonomic Tool Positioners.....	17				
250 lb. Capacity Tool Rails.....	18				
250 lb. Capacity Suspended Tool Rail Kits.....	18				
Tool Cranes – 50 lb. & 250 lb.....	19				

WARRANTY

Gleason warrants for a period of twelve (12) months after date of shipment, all goods manufactured by it to be free from defects in material and workmanship. If, within such warranty period, any such goods are proved, to Gleason's satisfaction, to be defective, such goods shall be repaired or, at Gleason's option, replaced f.o.b. Gleason's factory, without charge. Gleason's obligation hereunder shall be confined to such repair or replacement and shall be further conditioned upon Gleason receiving written notice of any alleged defect within 10 days after its discovery and, at Gleason's option, the return of the alleged defective goods to Gleason, f.o.b. its factory.

The foregoing warranty shall not apply to goods not manufactured by Gleason, or to goods which shall have been repaired or altered by others than Gleason so as to, in Gleason's judgement, adversely affect the same, or which shall have been subject to other than normal use of service, negligence, accident, or improper maintenance care, or storage. With respect to goods furnished but not manufactured by Gleason, the warranty obligations of Gleason shall in all respects conform and be limited to the warranty extended to Gleason by the supplier. The foregoing warranty is in lieu of all other express or implied warranties (except of title) and of all other obligations of Gleason.

Ergonomics Pays Dividends

If your company assembles, ships, or has an office, paying attention to workplace ergonomics increases productivity, reduces compensation claims and costs, and improves employee morale.

After much in-fighting, the OSHA Ergonomics Standard that became effective January 16, 2001, was voted down by the new congress. There is now no law to enforce ergonomic standards, but that doesn't mean your company won't benefit by properly designed and implemented workstations. Ask the insurance company that carries your liability and workers comp. They are vitally interested in the safety of your workplace, including ergonomic issues.

OSHA describes the problem as follows: "Work-related musculoskeletal disorders (MSDs) result when there is a mismatch between the physical capacity of workers and the physical demands of their jobs. Each year 1.8 million workers in the United States report work-related MSDs such as carpal tunnel syndrome, tendonitis and back injuries. About 600,000 MSDs are serious enough to result in workers having to take time off work to recover. **The solution to these injuries lies with ergonomics, the science of fitting the job to the worker.**"

Several factors make broad ergonomic standards or workplace rules difficult or even impossible to enforce:

- Ergonomics is "people based"; the tools and postures that help one person avoid MSDs may not help all. Each person is different.
- MSD symptoms tend to appear slowly, over time. By the time the worker begins to feel pain, it may be too late to avoid the injury.
- Personal worker comfort while performing a task may or may not mean the workstation is properly set up. For example, a worker may feel comfortable reaching for a part but may develop an MSD over time. Repetition is a factor.
- Each task tends to be different from an ergonomic standpoint.

As bleak as the above sounds, there are some basic factors. The five risk factors, as defined by OSHA, are:

- **Repetition:** repeating same motions every few seconds for 2 hours or more at a time or using a device steadily for more than 4 hours daily.
- **Force:** lifting more than 75 lbs. at any one time or pushing/pulling with more than 20 lbs. of initial force.
- **Awkward Postures:** repeatedly raising or working with hands above the head for more than two hours a day or working with back, neck or wrists bent for more than two hours total per day.
- **Contact Stress:** using hand or knee as a hammer more than ten times an hour for more than two hours total per day.
- **Vibration:** using tools that typically have high vibration levels (chain saws, jack hammers, etc.) for more than 30 minutes per day or tools with moderate vibration (jigsaws, grinders, etc.) for more than two hours per day.

Note how "time" plays a significant role in the risk factors. This suggests that workers should be frequently "rotated" from job to job.

A second element is making sure the workstation fits the individual so as to, as much as possible, eliminate lifting, reaching, etc.

These two concepts, task rotation and work place customization, are at odds without properly equipped workstations. Workstations must be fully adjustable and easily configured to the task and the worker. The relatively small investment required to properly outfit your workstations pays big dividends in fewer injuries, improved employee moral and increased production, positively affecting your company's profits.

Hubbell Workplace Solutions leads the way in solutions to ergonomic problems. Our broad, fully equipped line of modular workstations, tool balancers, torque arms, tool positioners and related equipment has found wide acceptance in ergonomically sensitive companies. In many workplaces, ergonomics was of relatively low importance until management became aware of the cost savings and increased production possible through the use of properly equipped workstations, workstations that can be adjusted to fit both the task and the worker.

UPDATE YOUR EXISTING BENCH

Easily, quickly, inexpensively retrofit old “beaters” as well as new benches.

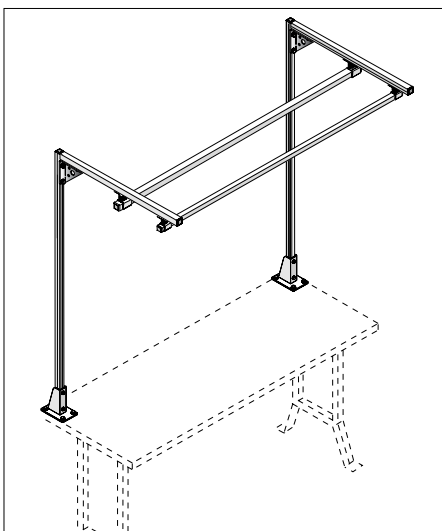

KITS

Hubbell Workplace Solutions kits contain everything needed to assemble ergonomically sound fixed workstations or mobile productivity boosters. All fasteners are included, with most already in place. The only tools required are two wrenches and a tape measure (drilling may be required to secure workstation to some benches). To complete assembly, attach bases to the bench (three styles of bases are available), slide components into position and tighten hardware. Fully customize with readily available components and accessories to make each workstation fit the task and fit the people performing the task. That's practical, affordable ergonomics.



Older bench equipped with new workstation kit and optional accessories.

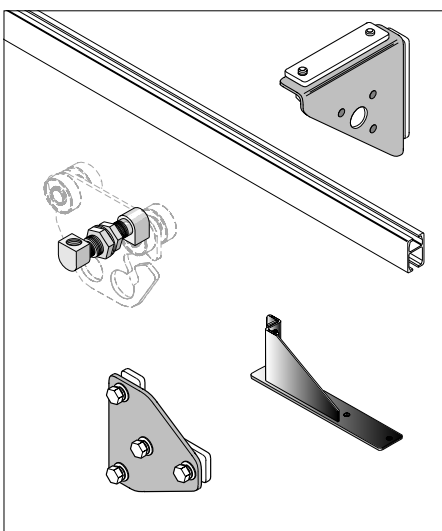

COMPONENTS

Most components which make up Hubbell Workplace Solutions kits are available separately. Components are often added to basic kits, further customizing them to fit the task. Components may also be used to construct workstations or other equipment using the practical “slide & clamp” assembly method. Where applicable, components include track nuts or clamp bars, plus other hardware, required for assembly.

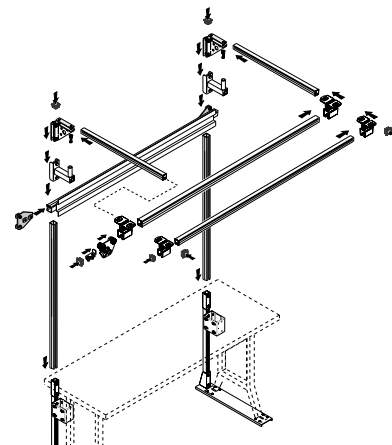

Kits, components and accessories assemble easily. Just slide into place and tighten.



ACCESSORIES

Hubbell Workplace Solutions workstation accessories increase utilitarian value and make the workplace more user friendly by adding functions. Typical accessories include; adjustable swing arms with a variety of attachments, torque neutralizing arms and tool positioners, air manifolds, bars for holding plastic tote bins, shelves, and lights. Accessories can be installed easily on HWS fixed or portable workstation kits.



Mobile productivity booster kits are complete, including all hardware. Assembly is required.



SINGLE COLUMN KITS are the efficient and economical way to meet ergonomic requirements. Each kit is complete with 180° swing or fixed boom, safety hook or balancer trolley and Universal Bracket for mounting everything from an air line fitting to peg board. Some models also include tool balancer, coiled air line, brass air line fitting and cord grip for use with electric tools. It's ready to mount on your work bench then customize...add swing arms with attachments, as shown below right, or other items as required. Horizontal boom has rated maximum capacity of 30 lbs.(13.5 kg). Bolts to any bench top. Hardware for mounting jib to bench not included. Balancer is easily adjusted to support tool weight allowing maximum productivity with minimum effort. Tool not included.



36" SWING BOOM KIT WITH TOOL TROLLEY
Except for tool and hardware to attach jib to your bench top, what you see here is what you get. Swing arms may be installed on 36" jib kits.

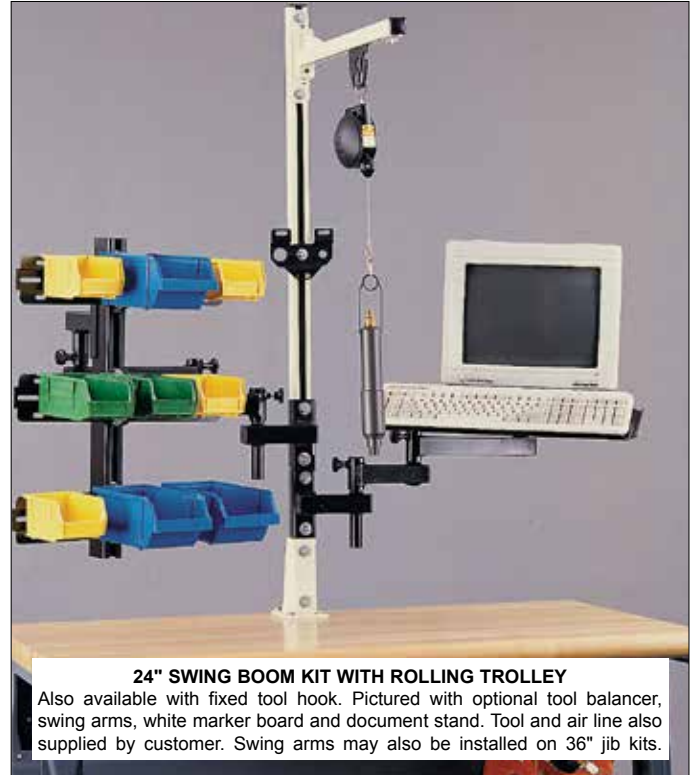

24" SWING BOOM KIT WITH ROLLING TROLLEY
Also available with fixed tool hook. Pictured with optional tool balancer, swing arms, white marker board and document stand. Tool and air line also supplied by customer. Swing arms may also be installed on 36" jib kits.

36" (914mm) LONG BOOM WORK STATION KIT (above, left) includes (1) fixed or swing 3 ft. WS30 swing boom, (1) 5 ft. WS50 vertical column, (1) 1.5, 2.5, or 5.0 lb.tool balancer, (1) balancer trolley, (1) end stop (with trolley only), (2) end caps, (1) WS-UH universal bracket, (1) brass air fitting, (1) cord grommet, (1) coiled 1/4" air line, (1) mounting base, all hardware required for assembly. Mounting fasteners not included. Does not include tool.

24" (610mm) LONG BOOM WORK STATION KIT (above, right) includes (1) fixed or swing 2 ft. WS30 boom, (1) 4 ft. WS50 vertical column, (1) balancer trolley or end stop hook, (1) end stop (with trolley only), (2) end caps, (1) angle bracket (fixed boom only), (1) WS-UH universal bracket, (1) mounting base, and all assembly hardware. Does not include fasteners for mounting base to bench. Does not include swing arms, balance reel, tool, air line or fittings shown in illustration.

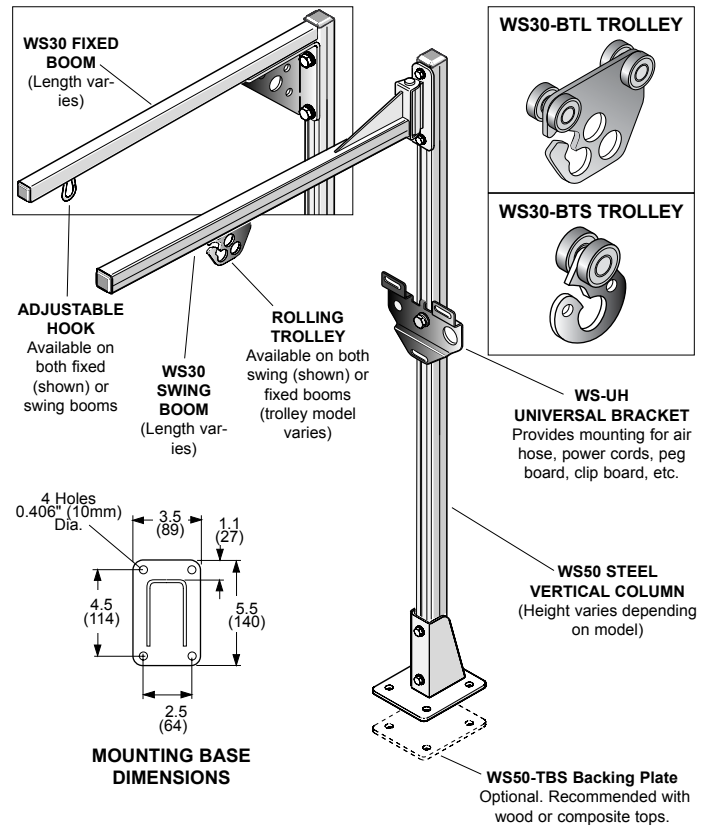

WS30 boom for total loads to 30 lbs. (13.5 kg)

Min - Max BALANCER CAPACITY	TROLLEY MODEL NUMBER	BOOM LENGTH & TYPE	VERTICAL COLUMN HEIGHT	WITH HOOK MODEL NO.	WITH TROLLEY MODEL NO.
0.5-1.5 lbs.	WS30-BTS	36" Swing	5' (1.5m)	na	WTS-050301
1.5-3.0 lbs.	WS30-BTS	36" Swing	5' (1.5m)	na	WTS-050302
3.0-5.0 lbs.	WS30-BTS	36" Swing	5' (1.5m)	na	WTS-050305
0.5-1.5 lbs.	WS30-BTS	36" Fixed	5' (1.5m)	na	WTF-050301
1.5-3.0 lbs.	WS30-BTS	36" Fixed	5' (1.5m)	na	WTF-050302
3.0-5.0 lbs.	WS30-BTS	36" Fixed	5' (1.5m)	na	WTF-050305
na	WS30-BTL*	24" Swing	4' (1.2m)	WHS-020400	WTS-020400
na	WS30-BTL*	24" Fixed	4' (1.2m)	WHF-020400	WTF-020400

* Only on models supplied with trolley.

TOOL RAIL KITS

DUAL RAIL, DUAL COLUMN, BENCH SUPPORTED

KITS



DUAL COLUMN WORKSTATION KITS include two straight rails, your choice of three mounting base styles and in a range of heights to fit virtually any bench and any task you have. Height of horizontal support rails is adjustable, as is position of rails and width (distance between vertical columns). Kits include one WS30 and one WS50 rail. Either or both may be used as tool rail by adding **optional** balancer trolleys. Trolley mounted TORQ-ARM™ may be used, as can most accessories. Additional components may be added to make these workstations even more functional. Consult your Hubbell Workplace Solutions distributor or contact the factory for more details.

TOOL RAIL KITS include (1) WS30 rail with hangers, (1) WS50 rail with hangers, (2) WS50 vertical columns, (2) WS50 horizontal 36" rails, (2) angle brackets with hardware, (2) bases as shown, (4) end stops, (8) end caps, and all assembly hardware.

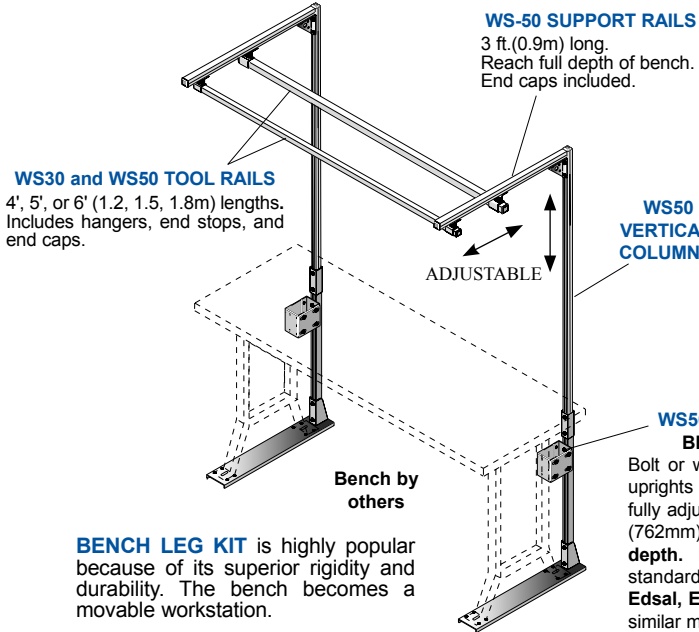

STRAIGHT RAIL BENCH LEG KITS

RAIL WIDTH ft. (m)	HEIGHT ABOVE BENCH	
	7 ft.(2.1m) (1)	7 ft.(2.1m) (1)
	30"(762) BASE	36"(914) BASE
4.0 (1.2)	#WKF-030740	#WKF-030746
5.0 (1.5)	#WKF-030750	#WKF-030756
6.0 (1.8)	#WKF-030760	#WKF-030766

NOTE 1: Nominal floor to top of vertical rail is 7'(2.1m). For 8'(2.4m) high models, change 7 in model number to 8, ie: WKF-030840

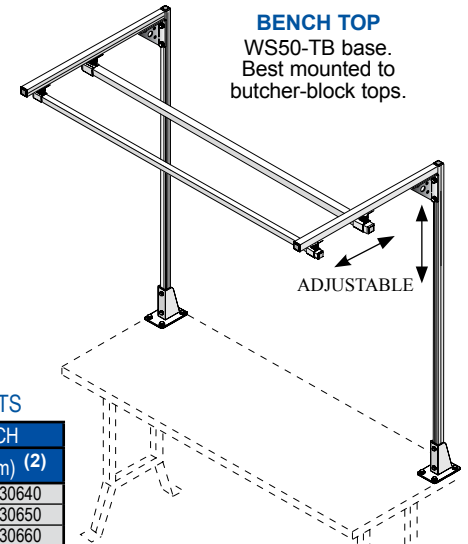

STRAIGHT RAIL BENCH TOP KITS

RAIL WIDTH ft. (m)	HEIGHT ABOVE BENCH	
	5 ft.(1.5m) (2)	6 ft.(1.8m) (2)
4.0 (1.2)	#WGB-030540	#WGB-030640
5.0 (1.5)	#WGB-030550	#WGB-030650
6.0 (1.8)	#WGB-030560	#WGB-030660

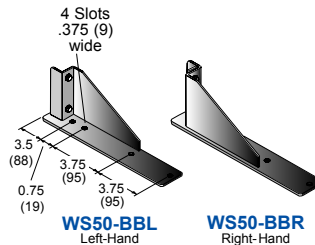
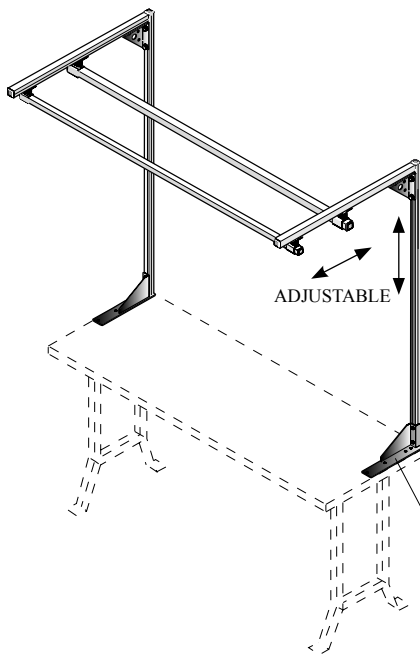

MOUNTING BASE DIMENSIONS

WS50-BBS Backing Plate (Same size as Mounting Base) Optional

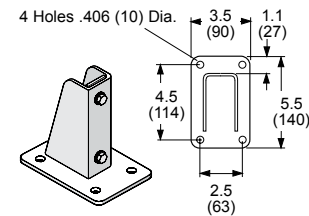

MOUNTING BASE DIMENSIONS

WS50-TBS Backing Plate (Same size as Mounting Base) Optional

STRAIGHT RAIL BENCH TOP KITS

RAIL WIDTH ft. (m)	HEIGHT ABOVE BENCH	
	5 ft.(1.5m) (2)	6 ft.(1.8m) (2)
4.0 (1.2)	#WKB-030540	#WKB-030640
5.0 (1.5)	#WKB-030550	#WKB-030650
6.0 (1.8)	#WKB-030560	#WKB-030660

NOTE 2: Height of bench will determine Tool Rail height.

TABLE BRACKET WS50-BBR and WS50-BBL bases. Predrilled to fit Equipito and Lyon steel tops.

Optional For All Bench Top Kits

BALANCER TROLLEY

WS30-BTL for WS30 rail.
WS50-BTL for WS50 rail.
Order separately.

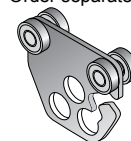



CURVED RAIL FOLLOWS THE WORK GUIDES TOOLS AND CONTROLS AROUND CORNERS

UNIQUE DIAMOND RAIL track and matching trolleys allow tools or control boxes to follow assembly line or conveyor path. Curved sections with 3 ft. (0.9m) radius form 90° corner and connect to other curved or straight track sections for smooth, non-stop trolley movement. Design and build your own system from components shown below. Threaded hangers may be hung from overhead beams or from WS50 rail using standard track nut. Trolleys include safety flanges to prevent fall if rollers fail. Capacity 30 lbs. (13.5 Kg).

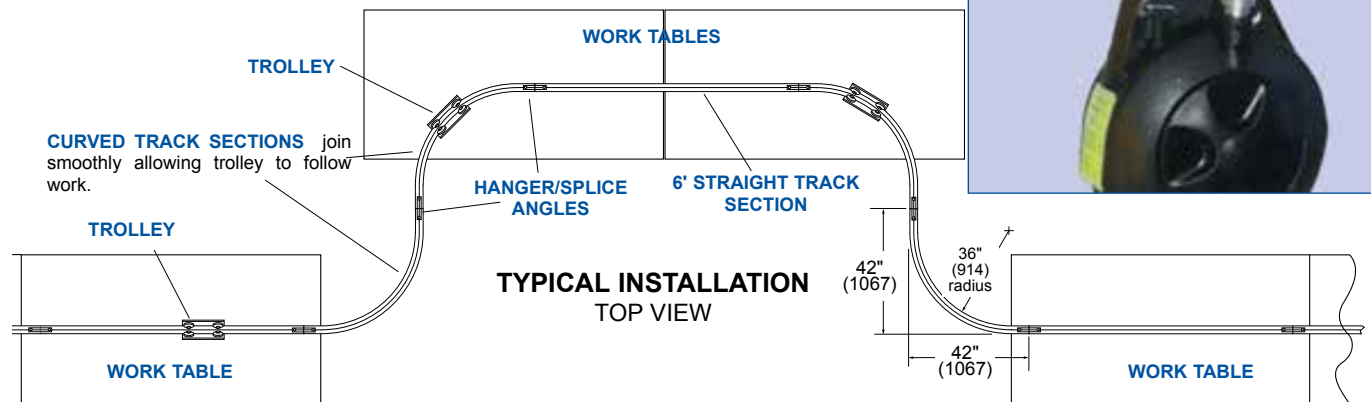
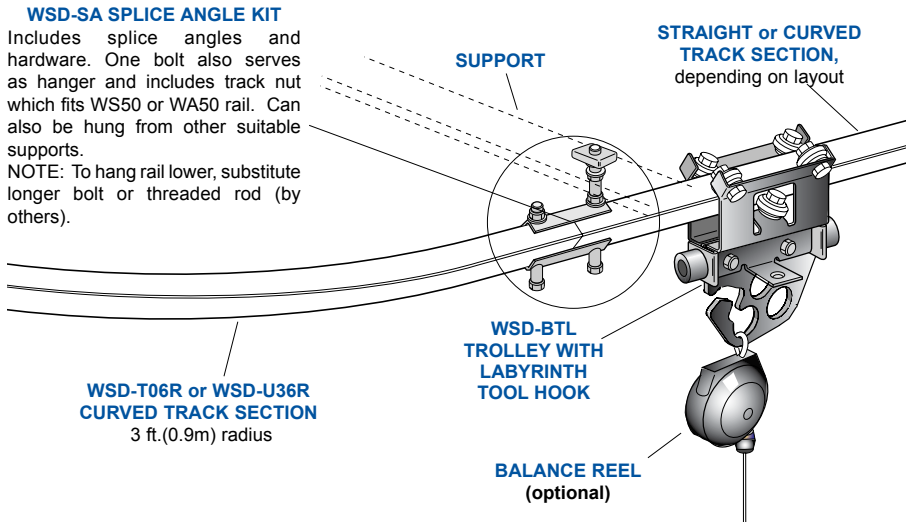

COMPONENT CHART		
DESCRIPTION	FINISH	MODEL NO.
6' (1.8m) STRAIGHT TRACK SECTION	BEIGE POLYESTER	WSD-T06
	UNFINISHED	WSD-U06
90° x 36" (914 mm) RADIUS CURVED TRACK SECTION	BEIGE POLYESTER	WSD-T36R
	UNFINISHED	WSD-U36R
SPLICE ANGLE KIT (includes (2) angles, hanger bolt, splice bolt, nuts & washers)	ZINC PLATED	WSD-SA
END STOP KIT (right, top) (includes end stop, hanger bolt, nuts & washers)	ZINC PLATED	WSD-ES
TROLLEY-LABYRINTH TOOL HOOK	BLACK POLYESTER	WSD-BTL
FESTOON TRAILER TROLLEY*	BLACK POLYESTER	WSD-RC12

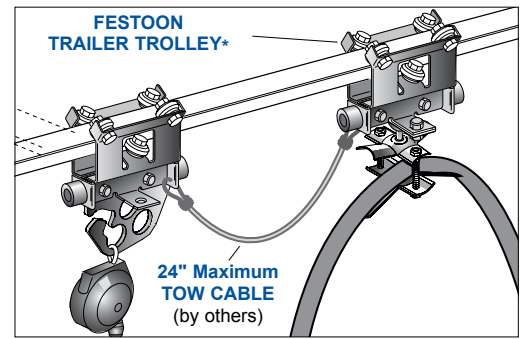
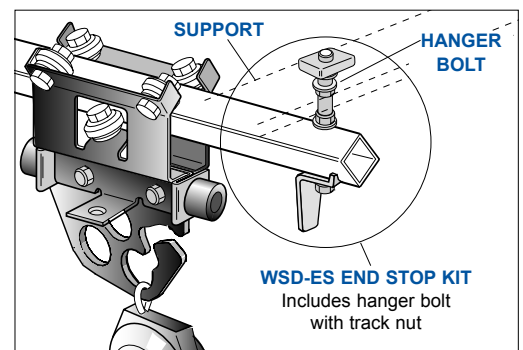

* **FESTOON TRAILER TROLLEY** (right, bottom) provides easy management of cord or hose supplying power to tool. Fits cable or hose 0.60–0.94" (15–24mm) diameter. Tow cable connecting tool trolley to trailer trolley should not exceed 24" in length.

TOOL BALANCERS

MAKE TOOLS WEIGHTLESS

ACCESSORIES



RELIABLE & ECONOMICAL SERIES 'BD'



SERIES 'BD' TOOL BALANCERS are the economical choice for balancing tools weighing up to 5 lbs (2.3kg). Molded ABS housing has a smooth exterior with rounded edges designed for maximum ergonomic appeal. Series "BD" balancers are the most modern, easiest to adjust, and reliable. Each balancer incorporates all of the important functions expected of a world class product.

SEVEN WAYS BETTER:

- 1- Hand-windable spring tension adjustment knob is flush with the housing.
- 2- Push-button tension release simplifies decrease of spring tension.
- 3- Rugged steel upper swivel hook with secondary safety cable provision.
- 4- Over-sized cable opening with direct in-line pull to reduce cable wear.
- 5- 270 lb (121.5kg) test 0.047" (1.2mm) dia. 7 x 7 strand galvanized steel aircraft cable nylon covered to 0.063" (1.6mm) O.D.
- 6- Adjustable cable stop and lower safety hook.
- 7- Matte black finish to minimize reflected light and reduce eye strain.

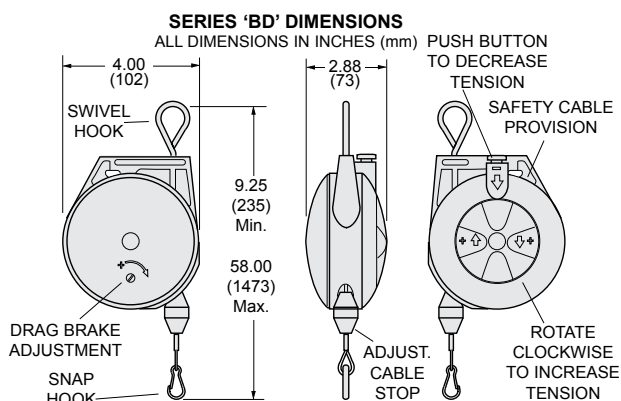

SELECTION CHART

MIN - MAX LOAD lbs. (kg.)	CABLE LENGTH* ft. (m.)	REEL WEIGHT lbs. (kg.)	MODEL NUMBER
0.5 - 1.5 (0.2 - 0.7)	6 (1.8)	1.3 (0.6)	BD-01
1.5 - 3.0 (0.5 - 1.4)	6 (1.8)	1.3 (0.6)	BD-03
3.0 - 5.0 (1.4 - 2.3)	6 (1.8)	1.5 (0.7)	BD-05

*Cable lengths listed are for "active" or "working" cable. Includes cable stop and safety hook.

HEAVY DUTY SERIES 'BG'

SERIES 'BG' reels feature rugged steel construction with black polyester baked finish, reinforced hanging bracket with forged clevis for ceiling mounting and extra holes for safety chain attachment. Spring is permanently lubricated and provides constant tension, adjustable for balancing tool in normal working zone (6 - 18 in. [152-457mm]). Cable is 920 lb. (414kg) test 0.09" (2.3mm) dia. 7 x 7 strand galvanized steel aircraft cable nylon covered to 0.12" (3.0mm) O.D. Includes safety tool clip and adjustable cable stop.



LOCKING MODELS include all features listed above plus a positive ratchet lock mechanism to allow locking of the cable at a specific height. A slight pull on the cable releases the lock which functions like a window shade. Lock feature may be disengaged externally when constant tension is required.

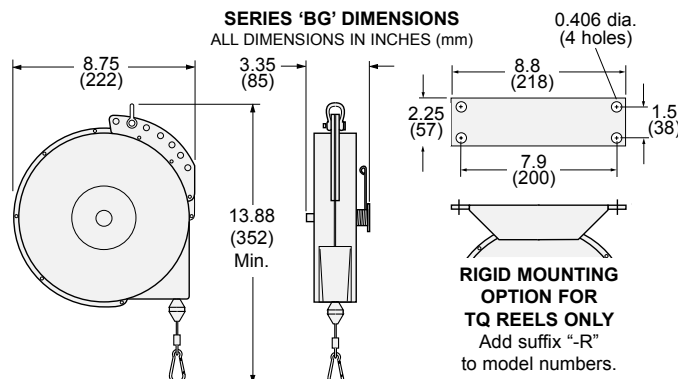

SELECTION CHART

MIN - MAX LOAD lbs. (kg.)	CABLE LENGTH* ft. (m.)	RATCHET LOCK	REEL WEIGHT lbs. (kg.)	MODEL NUMBER
BALANCERS (CONSTANT TOLL REELS) May be adjusted to balance through 6-18 in. (152-457mm) range.				
3 - 7 (1.4 - 3.2)	8 (2.4)	No	6 (2.7)	BG-03
5 - 10 (2.3 - 4.5)	8 (2.4)	No	6 (2.7)	BG-07
8 - 12 (3.6 - 5.4)	8 (2.4)	No	7 (3.2)	BG-10
10 - 15 (4.5 - 6.8)	8 (2.4)	No	8 (3.6)	BG-15
16 - 23 (7.2 - 10.4)	8 (2.4)	No	8 (3.6)	BG-20
16 - 23 (7.2 - 10.4)	8 (2.4)	No	8 (3.6)	BG-20SH**
22 - 27 (9.9 - 12.2)	8 (2.4)	No	8 (3.6)	BG-25
RETRACTORS (RATCHET LOCK) Retract tool upward when manually released				
3 - 7 (1.4 - 3.2)	8 (2.4)	Yes	6 (2.7)	BG-03-L
5 - 10 (2.3 - 4.5)	8 (2.4)	Yes	6 (2.7)	BG-07-L
8 - 12 (3.6 - 5.4)	8 (2.4)	Yes	7 (3.2)	BG-10-L
10 - 15 (4.5 - 6.8)	8 (2.4)	Yes	8 (3.6)	BG-15-L
16 - 23 (7.2 - 10.4)	8 (2.4)	Yes	8 (3.6)	BG-20-L
16 - 23 (7.2 - 10.4)	8 (2.4)	Yes	8 (3.6)	BG-20-LSH**
22 - 27 (9.9 - 12.2)	8 (2.4)	Yes	8 (3.6)	BG-25-L
TORQUE REELS (RATCHET LOCK AND LONGER CABLE)				
3 - 7 (1.4 - 3.2)	15.0 (4.5)	Yes	8 (3.6)	TQ1507***
5 - 10 (2.3 - 4.5)	15.0 (4.5)	Yes	10 (4.5)	TQ1510***
10 - 15 (4.5 - 6.8)	15.0 (4.5)	Yes	12 (5.4)	TQ1515***

*Cable lengths listed are "active" or "working" cable.

**Includes BG-SH "Shock Stop". See Below.

***Clevis mount. For rigid mount add "-R" to model number.

BALANCER ACCESSORIES

#STC-01 SAFETY CLIP



Brightly zinc plated steel safety latch for tool attachment and other uses. Measures 2.375" (60mm) long. One included with each BG reel. Rated capacity-70 lbs.

SAFETY CABLE/CHAIN

Strongly recommended, secondary steel cable or steel link chain. Prevents balancer from accidental fall. Balancers have extra holes for cable or chain.

LENGTH ft. (m.)	MODEL NO.
1.0 (0.3)	SC-BD1*
1.0 (0.3)	SC-BG1**
2.0 (0.6)	SC-BG2**
3.0 (0.9)	SC-BG3**

*Nylon covered steel cable.
**Steel link chain.

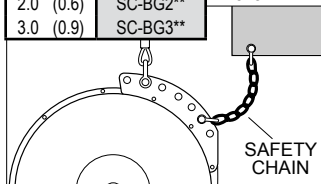

CLEVIS HANGERS

Galvanized forged steel hangers for mounting balancers, torque reels, etc. Measure 0.50" (13mm) between jaws. One #CVF-01 straight clevis included with each "BG" & "TQ" reel. #CVF-11 swivel clevis is optional extra. Pins included. Rated capacity-500 lbs.

#CVF-01
CLEVIS



#CVF-11
SWIVEL
CLEVIS



ADJUSTABLE CABLE SADDLE

Hangs from balancer cable above tool to provide strain relief for electrical cable or air hose. Available in three sizes. Includes safety clip.



OVERHANG CABLE

Nylon covered steel cable with safety clip. Brings tool closer to work area without unwinding cable from reel or mounting reel at a lower height.

LENGTH ft. (m.)	MODEL NO.
3 (0.9)	OC-03
5 (1.5)	OC-05
10 (3.0)	OC-10
15 (4.6)	OC-15

OVERHANG CABLE

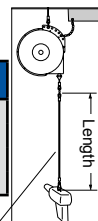

"SHOCK STOP" SHOCK ABSORBER

Minimize cable damage often caused by over-tensioning tool balancers. "Shock Stop" kit is easily installed. Can be used on any Series BD or BG balancer. Kit includes spring, cable stops, all hardware.

MODEL NO.
BD-SH
BG-SH

NEW!
Now available for BD Series





TAPERED DRUM TOOL BALANCERS

DRUM COMPENSATES FOR CHANGING SPRING RATE

Heavy-duty construction. Tapered drum compensates for changing spring rate. Direct spring powered - no motors or expensive gear trains to break or wear out.

Series "BH" Tapered Drum tool balancers keep tools within reach and reduce damage to tools by suspending them out of the way above the work surface. Risk of repetitive motion injury is reduced because only a light, downward force is required to place the tool in proper operating position. As the tool is lowered, and the spring is wound more tightly, the effective drum diameter increases to compensate for the increased force. Thus, when properly adjusted, the tapered drum keeps the tool at the positioned height.

Features include:

- Rugged die cast aluminum housing
- Both top and bottom hooks have spring-loaded safety latches
- Heavy duty steel wire rope
- Automatic safety catch prevents free-spooling if springs fail (not available on BH-02/BH-05)
- Easy adjustment with everyday tools from outside housing



Models "BH-02" through "BH-05"

Models "BH-09" through "BH-70"

Models "BH-85" through "BH-140"

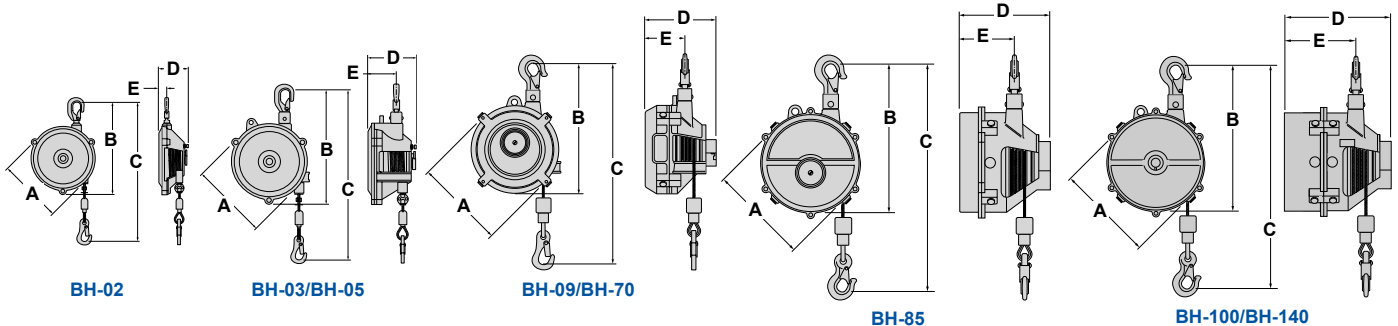

Selection Chart			
For Tool Weighing*	Cable Travel	Shipping Weight	Model Number
1.1 - 4.4 lbs.	3.3 ft.	2.2 lbs.	BH-02
2.2 - 6.6 lbs.	4.3 ft.	2.8 lbs.	BH-03
5.5 - 11 lbs.	4.3 ft.	3.3 lbs.	BH-05
9 - 20 lbs.	3.9 ft.	13.4 lbs.	BH-09
20 - 33 lbs.	3.9 ft.	13.4 lbs.	BH-15
33 - 48 lbs.	4.5 ft.	22.6 lbs.	BH-22
48 - 66 lbs.	4.5 ft.	22.6 lbs.	BH-30
66 - 88 lbs.	4.5 ft.	27.0 lbs.	BH-40
88 - 110 lbs.	4.5 ft.	27.0 lbs.	BH-50
110 - 132 lbs.	4.5 ft.	31.4 lbs.	BH-60
132 - 154 lbs.	4.5 ft.	31.4 lbs.	BH-70
154 - 187 lbs.	4.5 ft.	58.4 lbs.	BH-85
187 - 220 lbs.	4.5 ft.	56.0 lbs.	BH-100
220 - 264 lbs.	4.5 ft.	60.0 lbs.	BH-120
264 - 308 lbs.	4.5 ft.	61.0 lbs.	BH-140

* Tool weight includes hose or cord and other attachments which must be supported by balancer.

Dimensional Chart					
Model	A	B	C**	D	E
BH-02	5.00 in.	7.25 in.	11.25 in. min.	1.81 in	0.81 in
BH-03/BH-05	5.83 in.	8.25 in	12.50 in. min.	2.72 in.	1.44 in
BH-09/BH-15	7.00 in.	10.00 in.	13.00 in. min.	5.50 in.	2.88 in
BH-22/BH-70	8.60 in.	12.60 in.	17.00 in. min.	6.40 in.	3.19 in.
BH-85	9.50 in.	14.00 in.	20.00 in. min	9.75 in.	5.38 in
BH-100/BH-140	9.50 in.	14.00 in.	21.00 in. min	9.75 in.	5.38 in

** Minimum height fully retracted, inside of hook to inside of hook.

Safety Chain (recommended)		
Description	Shipping Weight	Model Number
2.0 ft. Steel Link Chain w/ Clevises	1.5 lbs.	SC-BH2
3.0 ft. Steel Link Chain w/ Clevises	2.0 lbs.	SC-BH3

ACCESSORIES for BH TOOL BALANCERS



Series BH Tool Balancer Accessories					
Balancer Model No.	Capacity		Safety Chain	Overhang Cable (4)	Tool Trolley
	Lbs.	(Kg)			
BH-02 (1)	1.1 - 4.4	(0.5 - 2.0)	NONE	OC-XX	WS30-BTL (6)
BH-03 (1)	2.2 - 6.6	(1.0 - 3.0)	SC-BG3	OC-XX	WS30-BTL (6)
BH-05 (1)	5.5 - 11	(2.5 - 5.0)	SC-BG3	OC-XX	WS30-BTL (6)
BH-09 (1)	9 - 20	(4.1 - 9.1)	SC-BG3	OC-XX (5)	WS50-BTL
BH-15 (2)	20 - 33	(9.1 - 15)	SC-BG3	OC-XX (5)	WS50-BTL
BH-22 (2)	33 - 48	(15 - 21.8)	SC-BG3	OC5MB-XX	WS50-BTL
BH-30 (2)	48 - 66	(21.8 - 30.0)	SC-BG3	OC5MB-XX	WS60-BT
BH-40 (2)	66 - 88	(30.0 - 40.0)	SC-BH3	OC5MB-XX	WS60-BT
BH-50 (2)	88 - 110	(40.0 - 50.0)	SC-BH3	OC5MB-XX	WS60-BT
BH-60 (2)	110 - 132	(50.0 - 60.0)	SC-BH3	OC5MB-XX	WS60-BT
BH-70 (2)	132 - 154	(60.0 - 70.0)	SC-BH3	OC5MB-XX	WS60-BT
BH-85 (2)	154 - 187	(70.0 - 85.0)	SC-BH3	OC8MB-XX	WS60-BT
BH-100 (3)	187 - 220	(85.0 - 100.0)	SC-BH3	OC8MB-XX	W6S-BT
BH-120 (3)	220 - 264	(100.0 - 120.0)	SC-BH3	OC8MB-XX	W6S-BT
BH-140 (3)	264 - 308	(120.0 - 140.0)	SC-BH3	OC8MB-XX	W6S-BT

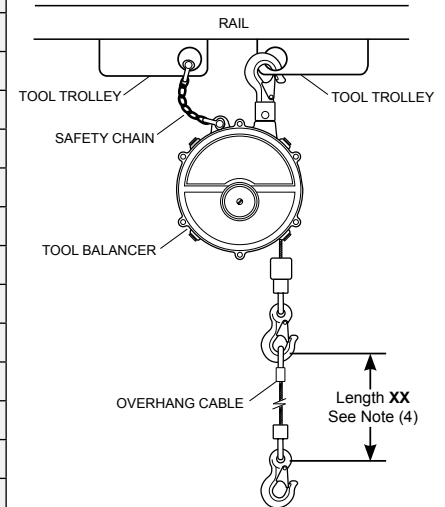

- (1) Balancer hook will fit WS30-BTL or WS50-BTL Tool Trolley.
- (2) Balancer hook will fit either WS50-BTL, WS60-BT or W6S-BT Tool Trolley.
- (3) Balancer hook will fit only W6S-BT Tool Trolley.
- (4) "XX" = Length req'd. When ordering indicate, -03 = 3 ft., -05 = 5 ft. or -10 = 10 ft.
- (5) Use with BH-09 or BH-15 requires one additional STC-01 Safety Clip.
- (6) WS50-BTL may also be used with BH-02, BH-03 and BH-05.

REPAIR PARTS for BH TOOL BALANCERS

BH-09 - 70 BALANCERS	
MODEL #	DESCRIPTION
BH09-SPG	SPRING FOR BH-09
BH15-SPG	SPRING FOR BH-15
BH22-SPG	SPRING FOR BH-22
BH30-SPG	SPRING FOR BH-30
BH40-SPG	SPRING FOR BH-40
BH50-SPG	SPRING FOR BH-50
BH60-SPG	SPRING FOR BH-60
BH70-SPG	SPRING FOR BH-70
BH915-CBL	CABLE FOR BH-09 & BH-15
BH2270-CBL	CABLE FOR BH-22 THRU BH-70
BH915-DRM	DRUM FOR BH-09 & BH-15
BH2270-DRM	DRUM FOR BH-22THRU BH-70

BH-02 - 05 BALANCERS	
MODEL #	DESCRIPTION
BH02-SPG	SPRING W/DRUM FOR BH-02
BH03-SPG	SPRING W/DRUM FOR BH-03
BH05-SPG	SPRING W/DRUM FOR BH-05
BH02-CBL	CABLE FOR BH-02
BH03-CBL	CABLE FOR BH-03
BH05-CBL	CABLE FOR BH-05

BH-85 - 140 BALANCERS	
MODEL #	DESCRIPTION
BH85-SPG	SPRING FOR BH-85
BH100-SPG	SPRING FOR BH-100
BH120-SPG	SPRING FOR BH-120
BH140-SPG	SPRING FOR BH-140
BH85140-DRM	DRUM W/CABLE FOR BH-85 THRU BH-140



'BA' AIR HOSE TOOL BALANCERS

Operate and Assemble with Ease

NEW!



The 'BA' Series Air Hose Tool Balancer is designed for small pneumatic tools. Integrating the air hose and support cable together keeps the work area safe and clean. These durable tool balancers provide easy handling for operators and assemblers that work with tools for long, continuous hours. The balancer allows a tool to be positioned over the work station for comfortable operation and can be used with small air tools. The effortless handling of the balancer provides comfortable tool operation and increased production.

The inside diameter of hose is 8.5mm which supplies enough air to operate the suspended air tool/device. When the spring failure happens, the fall prevention device will operate and stop the suspended tool/device. Safety cable is also included.



MODEL	CAPACITY lbs (kg)	HOSE TRAVEL ft (m)	HOSE ID in (mm)	WEIGHT lbs (kg)
BA-15	1.1 - 3.3 (0.5 - 1.5)	4.3 (1.3)	.33 (8.5)	4.2 (1.9)
BA-25	3.3 - 5.5 (1.5 - 2.5)	4.3 (1.3)	.33 (8.5)	4.4 (2.0)
BA-35	5.5 - 7.7 (2.5 - 3.5)	4.3 (1.3)	.33 (8.5)	4.6 (2.1)
BA-50	7.7 - 11.0 (3.5 - 5.0)	4.3 (1.3)	.33 (8.5)	4.6 (2.1)
BA-65	11.0 - 14.3 (5.0 - 6.5)	4.3 (1.3)	.33 (8.5)	4.9 (2.2)

WORK LIGHTS and POWER BARS



Here are fitting touches to your workplace: a fluorescent, overhead work light and a power bar. Both are custom designed for use on Workplace Solutions workstations. Two **Work Lights** are available. One has adjustable mounting brackets and two 48" fluorescent T8 lamps (included). The other has fixed brackets and four 48" fluorescent T8 lamps (included). **Power Bar** is available in two lengths; 36" with six grounded outlets and 60" with ten outlets. Power Bar features on/off switch, circuit breaker with reset button and mounting bar. Order mounting bar to fit width of your workstation. Mounting hardware is included. Lights include 10' cord and power bar includes 6' cord with standard 110v AC grounded plugs.

DESCRIPTION	MODEL NUMBER	FC* @ 3'	FC* @ 4'
48" Two Tube Adjustable Workstation Light	WBL-204A	93	70
48" Four Tube Fixed Workstation Light	WBL-404	185	130
"Z" Bracket to raise light flush with supports	WBL-40X-AM	N/A	N/A
36" Power Bar with 36" Mounting Bar	WPB-303A	N/A	N/A
36" Power Bar with 48" Mounting Bar	WPB-304A	N/A	N/A
36" Power Bar with 60" Mounting Bar	WPB-305A	N/A	N/A
36" Power Bar with 72" Mounting Bar	WPB-306A	N/A	N/A
60" Power Bar with 60" Mounting Bar	WPB-505A	N/A	N/A
60" Power Bar with 72" Mounting Bar	WPB-506A	N/A	N/A

* One foot-candle is equal to one lumen per square foot.

WORK LIGHTS FEATURE:

- Standard Clear Prismatic Lens.
- Accepts T8 fluorescent lamps.
- Polycarbonate safety tubes. Protect lamps, increase safety and meet OSHA, FDA, NEC and USDA requirements preventing contamination in case of lamp breakage.
- Model WBL-204A tilts 15° fore or aft and adjusts to bench width.
- Blacked-out side lens minimizes stray light.

POWER BARS FEATURE:

- Grounded outlets and plugs.
- On/off switch and circuit breaker with reset.
- Mounting bracket and hardware in length to fit your work bench.

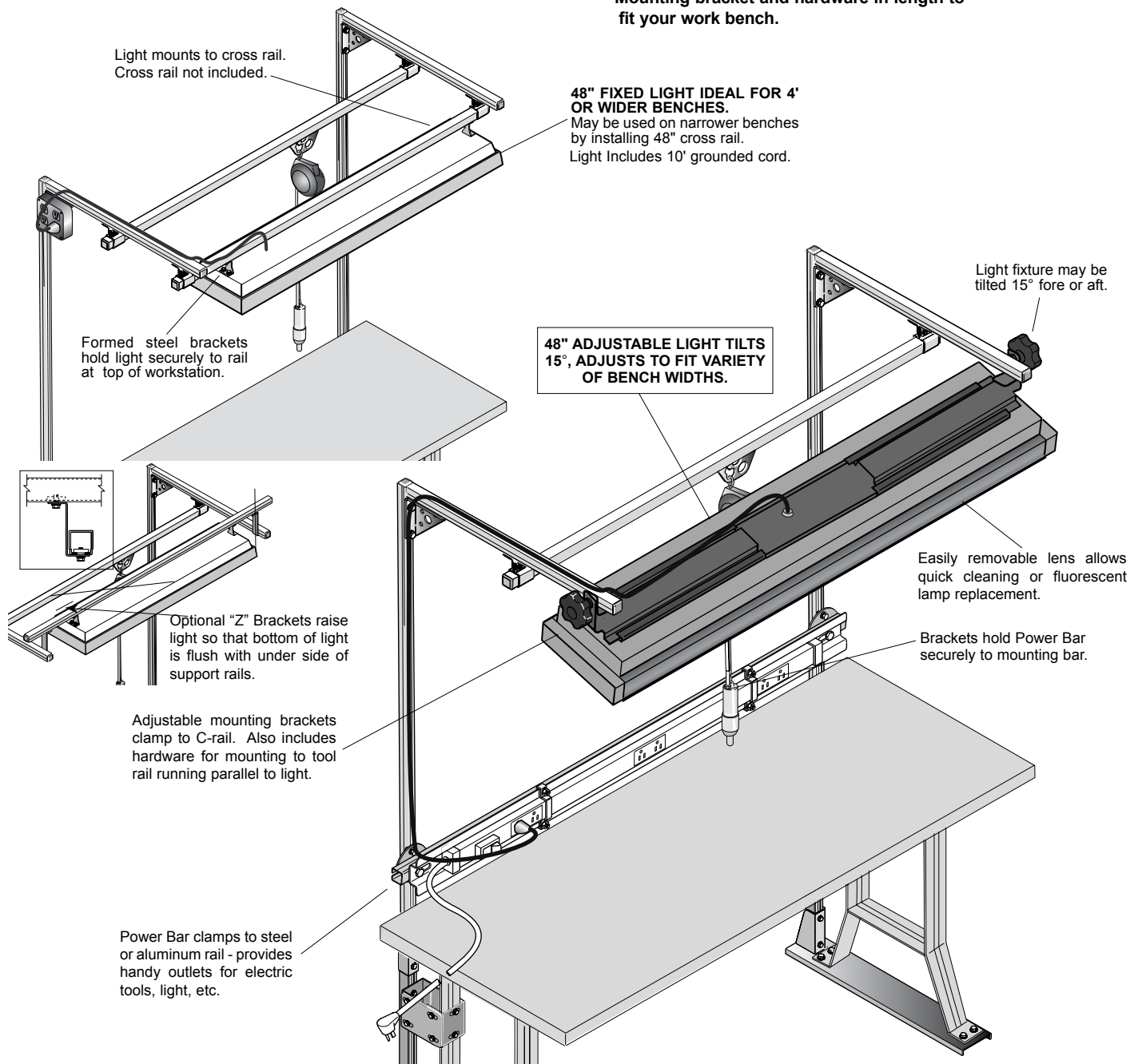

ACCESSORIES



MANIFOLD WITH BRACKETS

NEW DESIGN

Square tubing provides 66% more volume than former round tube. Ideal where multiple tools are used. Drilled and tapped for 3/8" NPT air inlets and outlets (see chart below for quantity). Mounts to vertical columns or top rails on workstations. Beige Polyester Finish. Mounting hardware included.



WIDTH ft. (m)	No. TAPS	SHIPPING WEIGHT	MODEL NUMBER
3.0 (0.9)	3	18 lbs.	WMAN-03C
4.0 (1.2)	4	22 lbs.	WMAN-04C
5.0 (1.5)	5	28 lbs.	WMAN-05C
6.0 (1.8)	6	33 lbs.	WMAN-06C
7.0 (2.1)	7	37 lbs.	WMAN-07C
8.0 (2.4)	8	42 lbs.	WMAN-08C

BIN BAR WITH BRACKETS

Holds hanging plastic bins. Mounts to WS50 or WA50 vertical columns. Beige Polyester Finish. Includes mounting brackets and hardware. Accepts Akro, Lewis, Nestler, Duralene and other brands of bin boxes. Maximum capacity 50 lbs. (22.5kg).

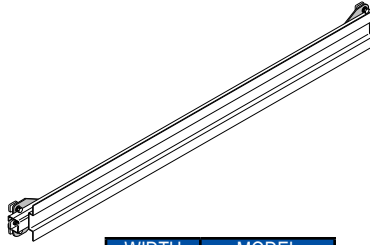

WIDTH ft. (m)	MODEL NUMBER
3.0 (0.9)	WS50-BB03A
4.0 (1.2)	WS50-BB04A
5.0 (1.5)	WS50-BB05A
6.0 (1.8)	WS50-BB06A
7.0 (2.1)	WS50-BB07A
8.0 (2.4)	WS50-BB08A
9.0 (2.7)	WS50-BB09A

SHELVES WITH BRACKETS

Hold up to 50 lbs. (22.5 kg). of parts, tools, etc. Adjustable tilt. Style "A", in 12" or 18" depth, mounts between vertical columns (column spacing fixed). Style "B" (12" deep only) mounts on front of columns (brackets may be adjusted to match column spacing). Polyester Finish. Shelves beige, brackets black. Mounting hardware included.

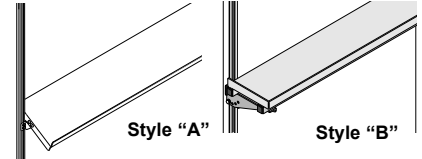

WIDTH* in (mm)	MODEL NUMBER	WIDTH* in (mm)	MODEL NUMBER
Style "A"-12"(305) Deep		Style "B"-12"(305) Deep	
Bracket Kit	WS50-SS00	Bracket Kit	WS50-SS00A
30.0 (762)	WS50-SS03	32.0 (812)	WS50-SS03A
42.0 (1067)	WS50-SS04	44.0 (1117)	WS50-SS04A
54.0 (1372)	WS50-SS05	56.0 (1422)	WS50-SS05A
66.0 (1676)	WS50-SS06	68.0 (1727)	WS50-SS06A
Style "A"-18"(457) Deep			
Bracket Kit	WS50-SS00		
30.0 (762)	WS50-SS183		
42.0 (1067)	WS50-SS184		
54.0 (1372)	WS50-SS185		
66.0 (1676)	WS50-SS186		

*Center-to-center spacing of vertical columns must be WIDTH + 2" (51mm) for Style "A" shelves.

ADJUSTABLE FOOT REST

EASY ON THE LEGS

Seated or standing, your workers can be more productive and more comfortable when a foot rest is used. In addition, use of a foot rest offers a degree of protection from back or leg strain. Fully adjustable and strong enough for heavy industrial applications, it's constructed of steel with extruded aluminum foot bar. Standard model measures 29" wide, 12.75" deep and 12.25" high. Smaller "under desk" version measures is 23" wide. Both rest on four non-skid rubber feet. The foot bar is easily adjustable from 4" to 11" above the floor and tilts 15° fore and aft. Frame is finished with matte black baked polyester coating. Foot bar is natural aluminum with two anti-skid strips.

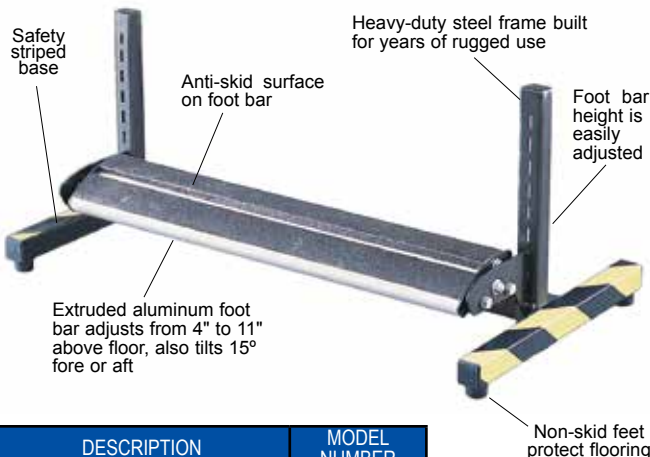
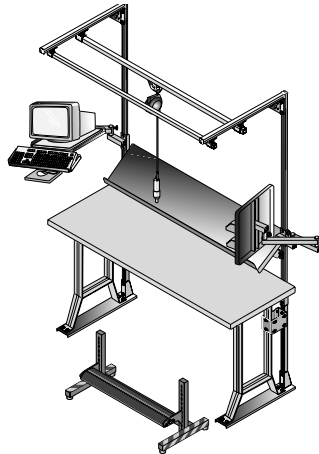

DESCRIPTION	MODEL NUMBER
Standard Adjustable Foot Rest	HWS-FR01
Office "Under Desk" Foot Rest	HWS-FR02

AIR LINES

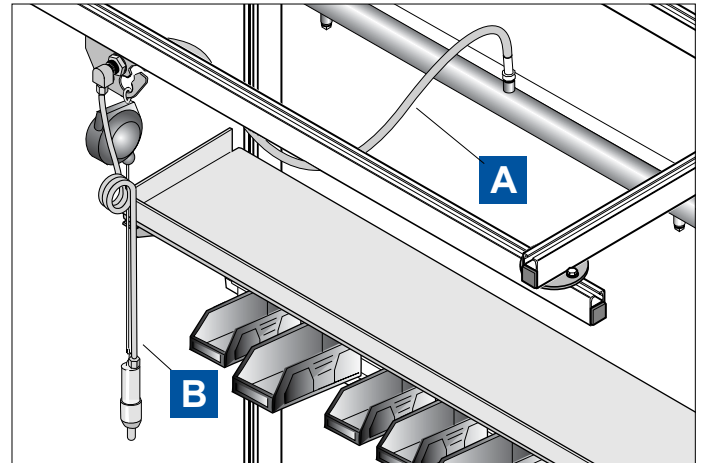

A The most flexible air line we have found. Ideal for connecting tool trolley to manifold or other supply because its flexibility does not interfere with trolley movement. Clear, reinforced plastic, 3/8" I.D. with 3/8" NPT male swivel fittings on both ends.

LENGTH ft. (m)	MODEL NUMBER
2.0 (0.6)	HWS-AL02
3.0 (0.9)	HWS-AL03
4.0 (1.2)	HWS-AL04
5.0 (1.5)	HWS-AL05
6.0 (1.8)	HWS-AL06

B Coiled hose from trolley to tool. Transparent blue polyurethane hose is flexible and light weight, doesn't interfere with tool positioning. Excellent memory retention. High chemical resistance. 3/8" O.D. x 1/4" I.D. x 4' extended length. 1/4" NPT male swivel fitting both ends.

MODEL NUMBER
HWS-AC04



SWING ARMS

MAKE YOUR WORKPLACE USER FRIENDLY

Swing arms with a variety of attachments, can be added to existing workstations or benches. Column mounts clamp on any **WS50** or similar column or rail. Bench mount can be bolted to any level surface. Arms, elbows and attachments slide together and can be adjusted to provide maximum worker efficiency, least worker strain. Black baked polyester finish (boards natural, beige or white as shown). Max capacity 30 lbs. (13.5 kg), arm alone or arm and elbow together. Use of three or more arms or elbows on one mount reduces capacity and is not recommended. Swing arms, elbows and attachments include adjustable drag brakes. Installation hardware included with column mounts.



Single Column Kit shown with swing arms. Swing arms may also be used with dual column kits.

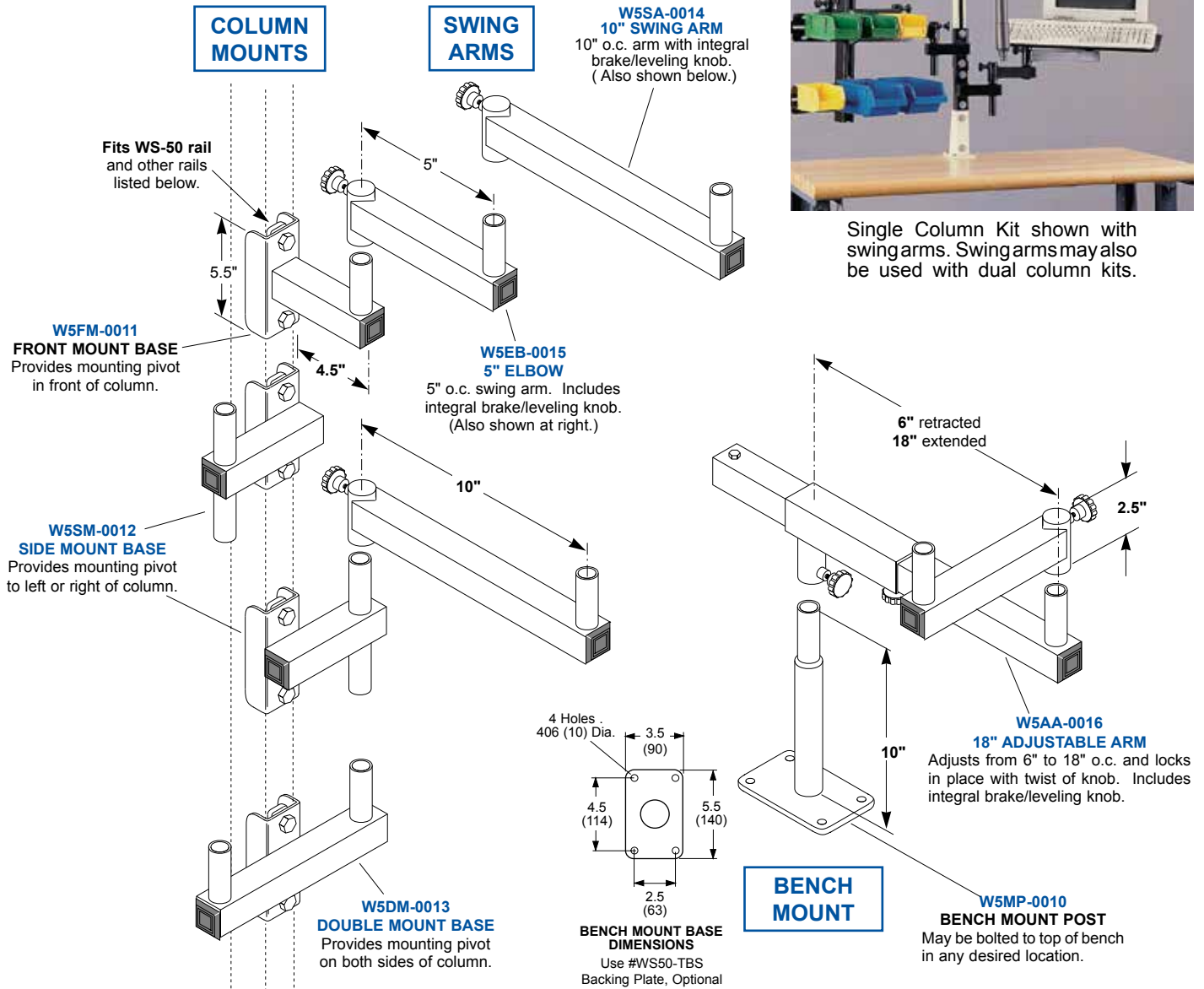

BASES MOUNT TO COLUMNS MADE BY OTHERS

The wrap-around design of the column mounts allows affixing to a variety of commonly used vertical support rails with dimensions similar to our WS50 rail. The rails listed below will accept these mounting bases.

BRAND	RAIL TYPE	BRAND	RAIL TYPE
Aeromotive	See bewa	Econoline	WS50, WA50
Bee-Line [Ⓛ]	B-22 & B-24	Kindorf [Ⓛ]	B-905
bewa [Ⓜ]	5400	Unistrut [Ⓛ]	P-1000, P-3000
DuctoWire	FC-CH2A	Wampfler [Ⓜ]	24-100

[Ⓛ] This is a "construction" rail and does not provide a suitable surface for wheels.
[Ⓜ] German product design

ACCESSORIES



ADD ACCESSORIES TO YOUR KIT MAKE YOUR WORKSTATIONS DO ALL THEY CAN DO

Customize your workstations to fit the task and the worker. Attachments slide easily onto mounts or swing arms (previous page). Adjustable brake may be tightened to limit free movement. Frame available separately for holding your custom board. Components finished as shown below. All mounting hardware included. Complete kits, including arms, also available. See details below, right.

W5BR-1018 (single bar)
W5BR-2018 (double bar, shown)
W5BR-3018 (triple bar)
BIN RACK
 19" w x 20" h (483 x 508).
 Heavy gauge steel with black finish.
 Accepts Akro, Lewis, Nestier, Duralene
 and other brands of bin boxes.

W5BR-0018
BAR ONLY
 Includes mounting disk.

W5PB-2018
PEG BOARD & MOUNT
 19" w x 20" h (483 x 508).
 Natural color composition board.

W5MB-2018
WHITE MARKER BOARD & MOUNT
 19" w x 20" h (483 x 508). Steel.
 Use magnets or wipe-off markers.

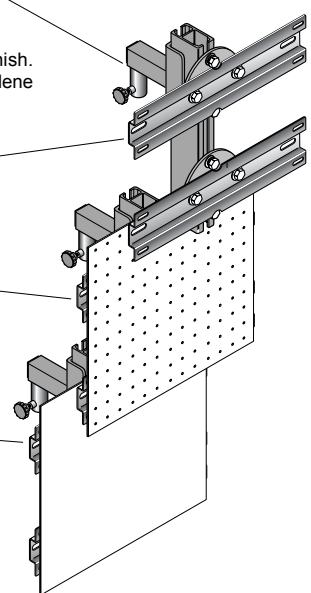

W5CT-0017
SWIVEL TRAY
 15" x 15" (381 x 381).
 Does not include Key Board Tray.
 Black baked polyester finish.

Also available: 10" x 10" flat tray
 which tilts 90°
 Order **W5ST-1010**

W5SS-0019 (Black)
W5SB-0024 (Beige)
SMALL DOCUMENT
STAND
 10" w x 12" h (254 x 305).
 Holds A size drawings.
 Features 90° tilt; flat to
 vertical.

W5LB-0025 (Beige)
W5DB-0026 (Black)
LARGE DOCUMENT STAND
 19" h x 17" w (483 x 432).
 Ideal for B or C size drawings.
 Features 90° tilt; flat to vertical.

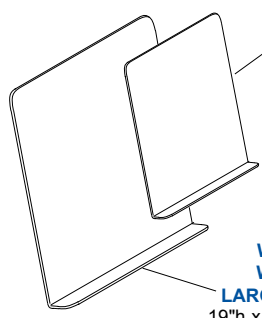

W5KT-0018
KEY BOARD TRAY & SUPPORTS
 9" x 21" (229 x 533). 15° tilt angle. Mounts to
 #W5CT-0017 Swivel Tray. Includes all mounting
 hardware. Also available: 12" x 6" tray with post for
 securing to arm. Swivels 360° and tilts up to 90°.
 Order model #W5KY-0612.

W5MT-0028
MOUSE PAD TRAY
 9" d x 10.5" w (229 x 267). Mounts
 to #W5KT-0018 Key Board Tray
 support brackets. Includes all
 mounting hardware.

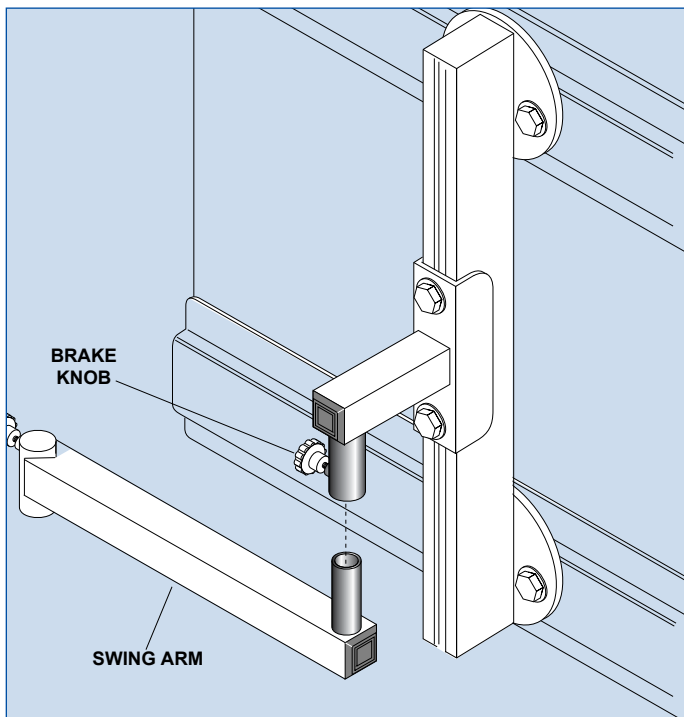
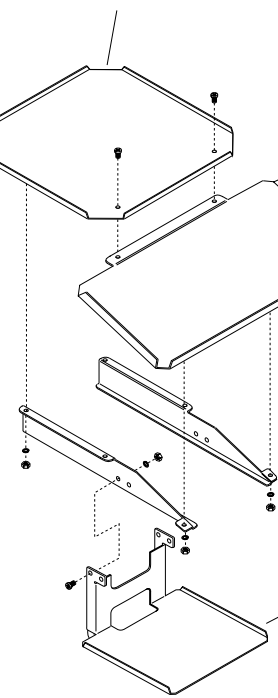

UNIVERSAL MOUNTING SYSTEM

Attachments slide easily onto swing arm or base posts.
 No tools required. Knob locks attachment in place following adjustment.

Kits—Include Base, Arms & Attachment

Easily fasten to vertical columns of Workstation. Each kit includes one 5" & one 10" arm plus mounting base and attachment shown. Rugged steel construction. All mounting hardware included.



Document Stand. 19" W x 17" H. 90° tilt, from flat to vertical.



Combo Computer, Keyboard & Mouse Tray. CPU tray 15" x 15"; Keyboard tray 9" x 21", tilts 20°. Mouse tray 9" D x 10.5" W.



Adjustable, See-thru Rack for Hanging Shelf Bins. 24" H x 18" W. (Accommodates Akro-Mils Akrobins™, as well as Gould Duralux™ bin boxes)

DESCRIPTION	MODEL NUMBER
Document Stand	W5DS-SAK
Adjustable Bin Rack	W5BB-SAK
Combo Computer & Keyboard Tray	W5CK-SAK

TORQ-ARM™ for ASSEMBLY TOOLS

COMPLETE WORKSTATION KIT OR TORQ-ARM ONLY

ACCESSORIES



Take a step towards OSHA Ergonomics standard compliance by fitting workstations with **Torq-Arm™** Torque Neutralizing arms. Available for either air or electric tools. Light weight anodized aluminum arms support weight of tool and allow easy positioning while preventing transmission of rotational forces to worker's hands or wrists. Units include tool balancer, telescoping positioning arms and rolling trolley for mounting in lateral tool rail on workstation or on bench mounted jib with swing boom (jib included). Electric tool models feature secure tool clamp which may also be used for electric or air powered pistol grip tool. Air tool models feature a U-joint manifold which supplies air to tool and allows vertical and horizontal tool positioning. **JIB MOUNTED TORQ-ARM™ KIT** includes all parts necessary for assembling a complete, ergonomically correct TORQ-ARM™ on an existing bench. Maximum torque rating is 15 foot pounds (20N.m). All steel parts protected with durable baked polyester finish. Order model for correct type and weight tool. Tools not included.

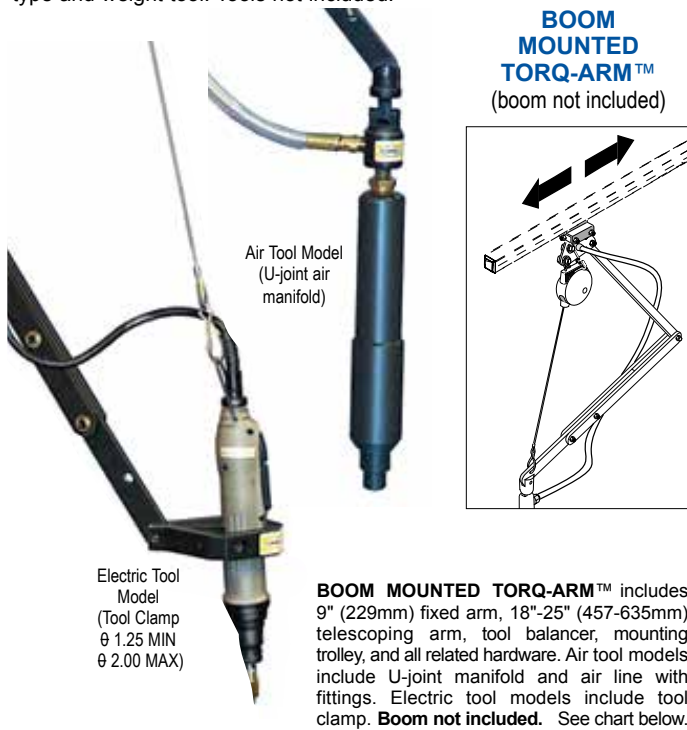

JIB MOUNTED TORQ-ARM™

(includes jib)

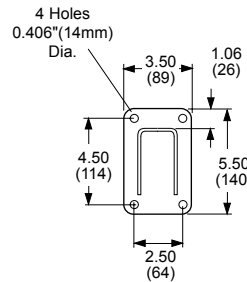

WS50-TB MOUNTING BASE DIMENSIONS

#WS50-TBS Backing Plate Optional. Recommended on wood or composite tops.

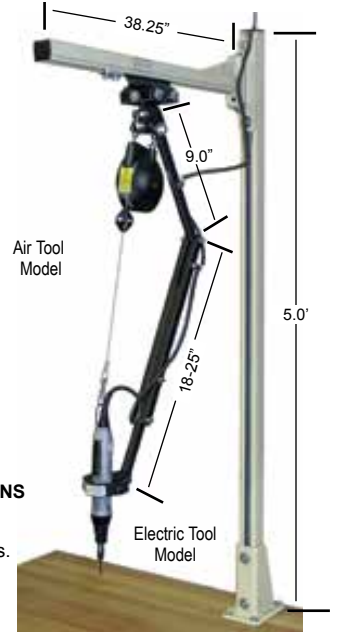

BENCH MOUNTED TORQ-ARM™ JIB includes (1) WS30 swing boom, (1) WS50 vertical column with base, (2) end caps, (1) end stop, hardware for mounting boom to column and column to base, and (1) TORQ-ARM™ kit including 9" (229mm) fixed arm, 18"-25" (457-635mm) telescoping arm, tool balancer, mounting trolley, and all related hardware. Air tool models include U-joint manifold and air line with fittings. Electric tool models include tool clamp.

TORQ-ARM™ mounted on Jib with Swing Boom.

Mounts to bench top. Jib included.

Min. - Max. TOOL WEIGHT	TOOL TYPE	UNIT WEIGHT	MODEL NUMBER	
			WS30 BOOM	WS50 BOOM
0.5-1.5 lbs. (0.2-0.7 kg)	Air	5 lbs. (2.25 kg)	WS30-FA-1	WS50-FA-1
1.5-3.0 lbs. (0.7-1.4 kg)	Air	5 lbs. (2.25 kg)	WS30-FA-2	WS50-FA-2
3.0-5.0 lbs. (1.4-2.3 kg)	Air	5 lbs. (2.25 kg)	WS30-FA-5	WS50-FA-5
0.5-1.5 lbs. (0.2-0.7 kg)	Electric	5 lbs. (2.25 kg)	WS30-FE-1	WS50-FE-1
1.5-3.0 lbs. (0.7-1.4 kg)	Electric	5 lbs. (2.25 kg)	WS30-FE-2	WS50-FE-2
3.0-5.0 lbs. (1.4-2.3 kg)	Electric	5 lbs. (2.25 kg)	WS30-FE-5	WS50-FE-5

Min. - Max. TOOL WEIGHT	TOOL TYPE	UNIT WEIGHT	MODEL NUMBER
0.5-1.5 lbs. (0.2-0.7 kg)	Air	20 lbs. (9 kg)	WS30-RA-1
1.0-2.50 lbs. (0.5-1.1 kg)	Air	20 lbs. (9 kg)	WS30-RA-2
2.0-5.0 lbs. (0.9-2.3 kg)	Air	20 lbs. (9 kg)	WS30-RA-5
0.5-1.5 lbs. (0.2-0.7 kg)	Electric	20 lbs. (9 kg)	WS30-RE-1
1.0-2.50 lbs. (0.5-1.1 kg)	Electric	20 lbs. (9 kg)	WS30-RE-2
2.0-5.0 lbs. (0.9-2.3 kg)	Electric	20 lbs. (9 kg)	WS30-RE-5

RAIL MOUNTED TORQ-ARM™

Rail Not Included

Designed to be mounted on straight overhead tool rails. Specify **WS30** or **WS50** rail. See chart below.

OVERHEAD RAIL MOUNTED TORQ-ARM™ includes 9" (229mm) fixed arm, 18"-25" (457-635mm) telescoping arm, tool balancer, mounting trolley for WS30 or WS50 straight rail (check rail size before ordering), and all related hardware. Air tool models include U-joint manifold and air line with fittings. Electric tool models include tool clamp. Mounting rail and tool not included.

TORQ-ARM™ ONLY-RAIL MOUNTED

Min. - Max. TOOL WEIGHT	TOOL TYPE	UNIT WEIGHT	MODEL NUMBER	
			WS30 RAIL	WS50 RAIL
0.5-1.5 lbs. (0.2-0.7 kg)	Air	5 lbs. (2.25 kg)	WS30-TA-1	WS50-TA-1
1.5-3.0 lbs. (0.7-1.4 kg)	Air	5 lbs. (2.25 kg)	WS30-TA-2	WS50-TA-2
3.0-5.0 lbs. (1.4-2.3 kg)	Air	5 lbs. (2.25 kg)	WS30-TA-5	WS50-TA-5
0.5-1.5 lbs. (0.2-0.7 kg)	Electric	5 lbs. (2.25 kg)	WS30-TE-1	WS50-TE-1
1.5-3.0 lbs. (0.7-1.4 kg)	Electric	5 lbs. (2.25 kg)	WS30-TE-2	WS50-TE-2
3.0-5.0 lbs. (1.4-2.3 kg)	Electric	5 lbs. (2.25 kg)	WS30-TE-5	WS50-TE-5

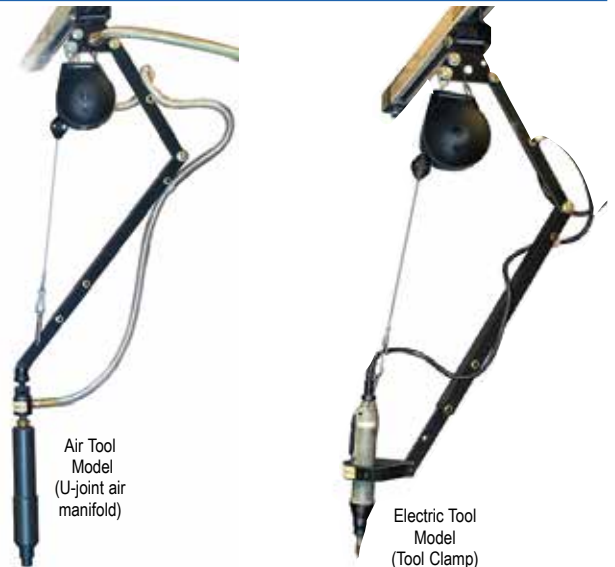



TOOL POSITIONERS

NEUTRALIZE TORQUE, ELIMINATE TOOL LIFTING

Tool Positioners stop shock and torque transmission to wrists and arms, one of the major causes of musculoskeletal disorders (MSDs). Dual parallel arms also keep tool in a vertical position as it is moved across work area, eliminating need to lift or twist tool. Spring tension is adjustable for tools from 1.0–7.0 pounds. Air tools (AM models) attach directly to bottom of air manifold. Electric tools (EC models) clamp to adapter plate. **Choice of positioner mounting.** Post models mount to top of work surface, positioner is adjustable on 26" post (included). Column mounted positioners include adjustable bracket for attaching to workstation upright. Maximum torque rating is 97 inch pounds (11N.m).

- Reduces transmission of shock and torque to worker's hand, wrist or arm
- Automatically positions tool perpendicular to work piece
- Adjustable tension supports air or electric powered tools from 1.0–7.0 lbs.
- **Arm reach: 15" minimum – 31.5" maximum from base pivot point**

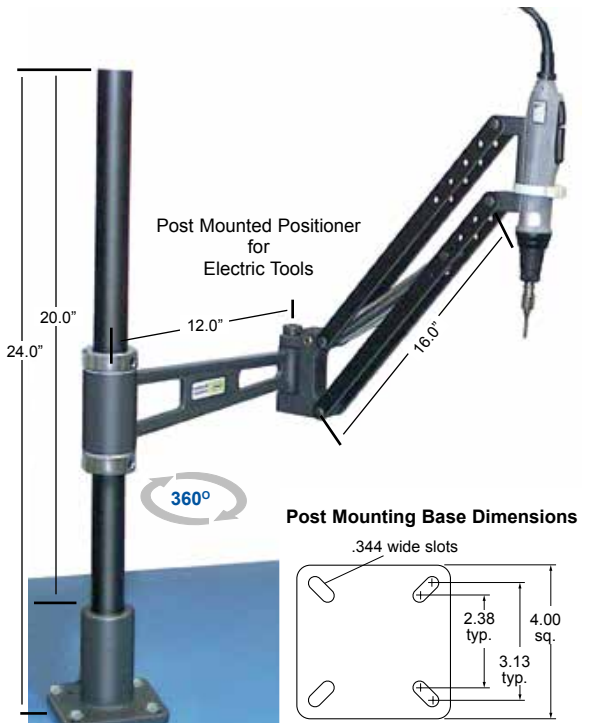

Min. - Max. TOOL WEIGHT	TOOL TYPE	MOUNTING TYPE	UNIT WEIGHT	MODEL NUMBER
1.0 – 7.0 lbs. (0.45–3.15 kg)	Air	Post (post included)	5 lbs. (2.25 kg)	WSP-AM
1.0 – 7.0 lbs. (0.45–3.15 kg)	Air	Bracket (bracket included)	5 lbs. (2.25 kg)	WS50-AM
1.0 – 7.0 lbs. (0.45–3.15 kg)	Electric	Post (post included)	5 lbs. (2.25 kg)	WSP-EC
1.0 – 7.0 lbs. (0.45–3.15 kg)	Electric	Bracket (bracket included)	5 lbs. (2.25 kg)	WS50-EC

250 lb. CAPACITY RAIL

FOR THOSE HEAVY DUTY APPLICATIONS

ACCESSORIES



RAIL & HANGER KITS

Designed for large air tool balancers, these tool rail kits are similar to our W3F and W5F tool support kits but much heavier. Must be supported every 6 ft. (1.8m) minimum to maintain full rated capacity.

- The basic tool rail is the key component on which all accessories hang
- Maximum 250 lb.(113kg) safe load rating
- Galvanized for maximum corrosion protection
- Available in 6, 12 and 18 ft. (1.8, 3.6, 5.4m) lengths
- May be joined for any length
- Can be mounted on benches, booms, or ceilings

250 lb. CAPACITY TOOL RAIL KIT includes (1) galvanized steel rail (length per model), (1) heavy duty tool trolley, (2) hanger brackets, and (2) end stops.

WS60-HG HANGER

Supports rail from overhead structures. Does not interfere with free trolley movement. Two mounting holes, .406"(10) sq. for 3/8" carriage bolts

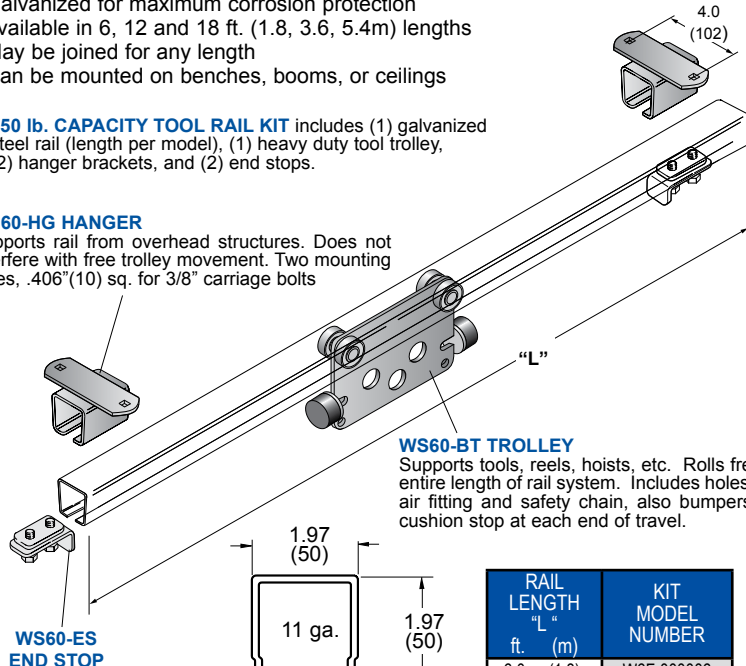

WS60-BT TROLLEY

Supports tools, reels, hoists, etc. Rolls freely entire length of rail system. Includes holes for air fitting and safety chain, also bumpers to cushion stop at each end of travel.

WS60-ES END STOP

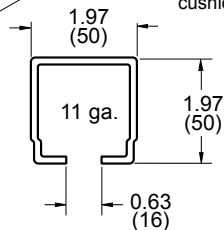

WS60 Rail

For loads up to 250 lbs (113kg).

RAIL LENGTH "L"		KIT MODEL NUMBER
ft.	(m)	
6.0	(1.8)	W6F-000006
12.0	(3.6)	W6F-000012
18.0	(5.4)	W6F-000018

COMPONENTS

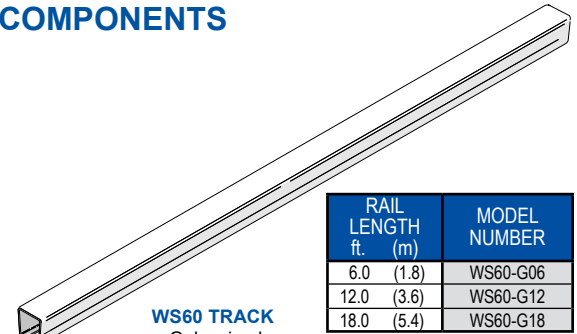

WS60 TRACK

Galvanized

USE: Horizontal supports, rail for lateral movement of tools, controls, hoists, etc; up to 250 lbs. (113 kg) maximum total load.

RAIL LENGTH ft. (m)	MODEL NUMBER
6.0 (1.8)	WS60-G06
12.0 (3.6)	WS60-G12
18.0 (5.4)	WS60-G18

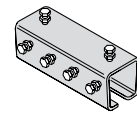

WS60-CP RAIL COUPLER
Zinc plated steel.
USE: Joins track sections.

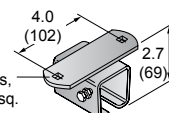

WS60-HG HANGER
Zinc plated steel.
USE: Hangs/supports WS60 track from overhead beams, joists, or other structures.



WS60-ES END STOP
Zinc plated steel.
USE: Installs in rail to stop trolley

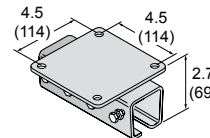

WS60-HC HANGER/COUPLER
Zinc plated steel.
USE: Joins track sections.

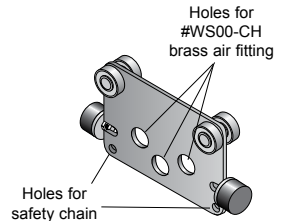

WS60-BT ROLLING TROLLEY
Black polyester finish.
USE: Supports tools, balance reels, torque reels, push button control stations.

Heavy-Duty Hanger

Use components at right to hang Tool Rail from overhead supports

Hanging a tool rail from an overhead structure may be the best way to put a workstation where it's needed. 250 lb. capacity hangers, for use with WS60 steel track, are available as individual components only...not as kits. Thru bolts both top and bottom (see photo) act as a safety net. Thru bolts included with the mounting bases. Tool track must be supported every six feet to preserve 250 lb. capacity rating. Vertical C-60 supports must be field-cut to length to support rail at desired height.

DESCRIPTION	MODEL NUMBER
Mounting Base for C-60 Track	WS60-MB
C-60 Hanger Coupler	WS60-HC
Hardware Kit*	WS60-HW

*Hardware Kit includes (4) 1/2 x 1 1/2 bolts, nuts, lock washers and flat washers required to attach hanger coupler to mounting base.

THRU BOLTS FOR SAFETY
(included with base)

VERTICAL C-60 TRACK
Length to suit.

WS60-MB MOUNTING BASE

HORIZONTAL C-60 TRACK
Length to suit.

WS60-HC HANGER COUPLER
Supports and joins lengths of C-60 track.
Hanger may be rotated 90°.

WS60-EHT02 FESTOON TROLLEY
(shown)
WS60-BT TOOL TROLLEY
may also be used.

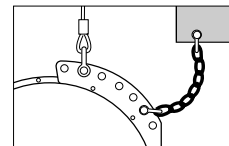
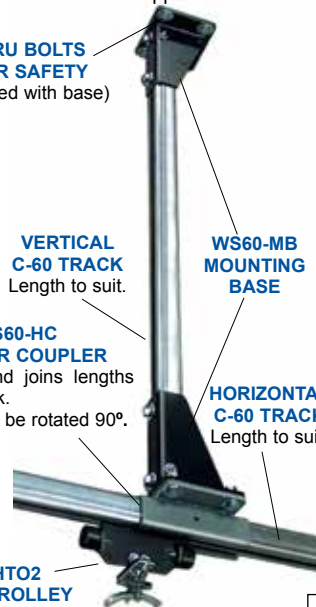

SAFETY CHAIN

Strongly recommended, steel link chain prevents balancer or tool rail from accidental fall. Includes clevis both ends.



WS-U6 U-BOLT ASSEMBLY
Zinc plated steel
USE: Secures WS60-MB mounting base or other flat plates to 3" dia. vertical column

FESTOON COMPONENTS

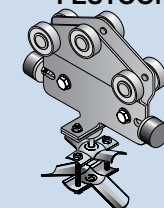

WS60-EHT01 (02, 03) FESTOON TROLLEY
Black polyester finish.
USE: Supports cable or hose in festoon system.

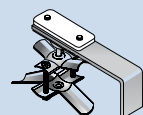

WS60-EC01 (02, 03) END CLIP
Black polyester finish.
USE: Secures cable or hose and acts as end stop in festoon system

CABLE/HOSE SIZE TABLE

0.31"-0.59" o.d.....01
0.60"-0.94" o.d.....02
0.95"-1.25" o.d.....03

ACCESSORIES



HEAVY DUTY TOOL CRANES

50 lb. or 250 lb. CAPACITY

Rugged bridge crane design concept allows overhead tool handling with maximum safety and minimum cost. Uses proven components rolling in standard WS-50 or WS-60 (steel) or WA-50 (aluminum) rails. 250 lb. capacity unit features doubled tool rail for maximum strength on spans over 6'. To speed installation, trolleys, hangers and tool track bridge are pre-assembled into single units, as is tool rail. Balance reel and tool not included.

50 lb. (22.5 kg) CAPACITY

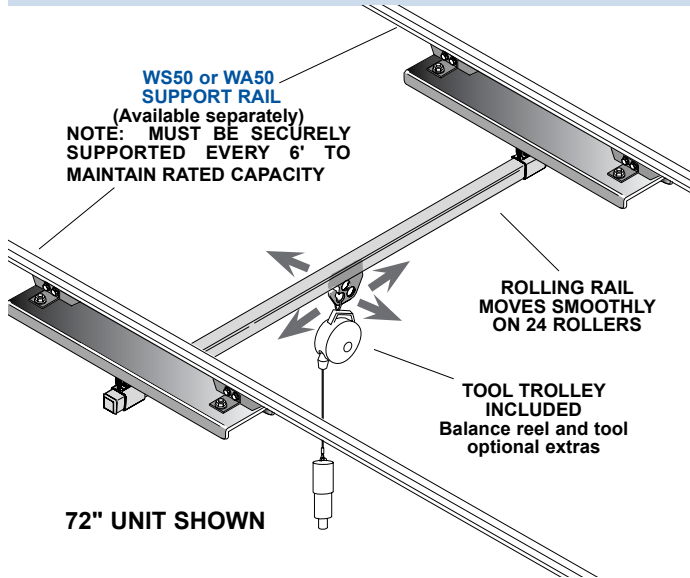

250 lb. (112.5 kg) CAPACITY

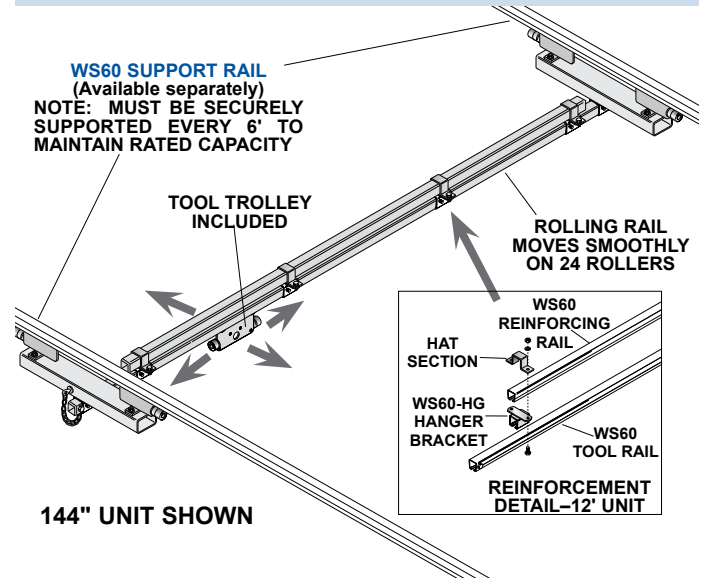

ASSEMBLY DETAILS

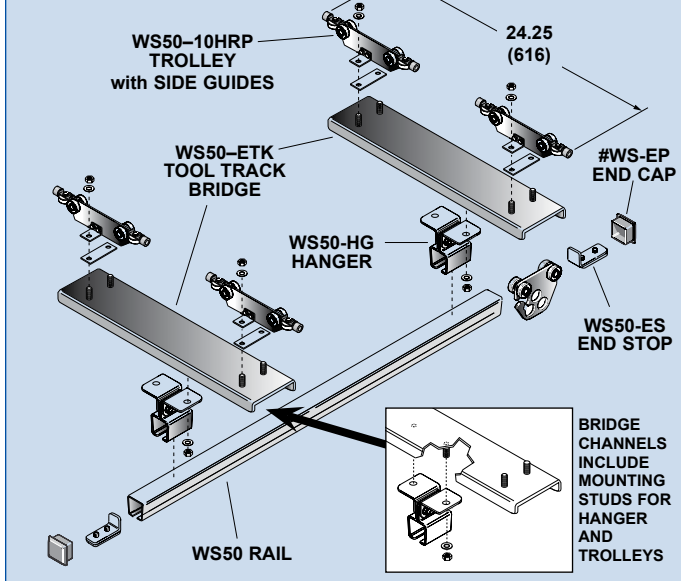

ASSEMBLY DETAILS

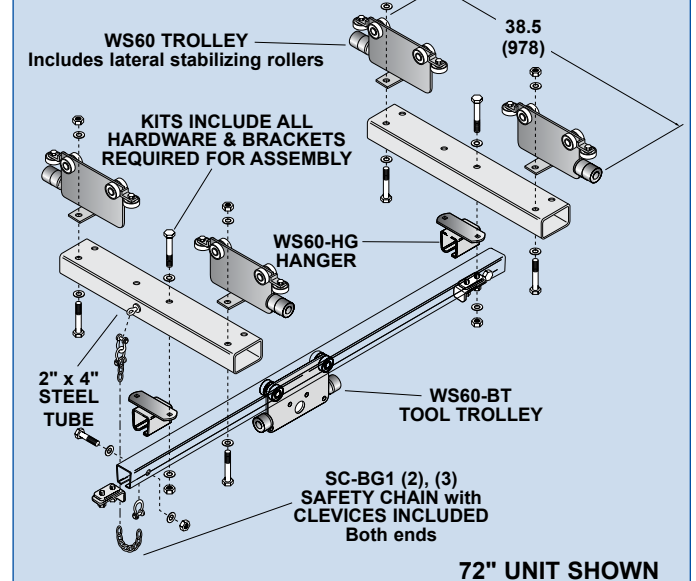

Heavy Duty Rolling Rail mounts in two parallel rails, which must be supported every 6' (1.8m) to maintain rated capacity. Recommended distance between support rails is length of tool rail less 12" (305mm). **MAXIMUM RATED CAPACITY OF ROLLING RAIL** includes tool, balancer, and attachments.

50 lb. Capacity Rolling Tool Rail includes (4) WS50-10HRP plain trolleys, (2) WS50-ETK tool track bridges, (2) WS50-HG hanger brackets, (1) WS50-BTL tool trolley, (2) WS-EP end caps, (2) WS50-ES end stops, (1) WS50 tool rail (length per model) and all assembly hardware.

250 lb. Capacity Rolling Tool Rail includes (4) WS60-FT trolleys, (2) 2" x 4" steel tool track bridges, (2) WS60-HG hanger brackets, (1) WS60-BT tool trolley, (2) WS60-ES end stops, (1) WS60 tool rail (length per model), (1) WS60 reinforcing rail (144" unit only), (2) safety chains, assembly brackets and hardware.

MODEL CHART

DESCRIPTION	TOOL RAIL in. (mm)	CAPACITY lbs. (kg)	MODEL NUMBER
4 Ft. Overhead Tool Crane	48" (1219)	50 lbs. (22.7 kg)	WS50-ET04
5 Ft. Overhead Tool Crane	60" (1524)	50 lbs. (22.7 kg)	WS50-ET05
6 Ft. Overhead Tool Crane	72" (1829)	50 lbs. (22.7 kg)	WS50-ET06
9 Ft. Overhead Tool Crane	108" (2743)	50 lbs. (22.7 kg)	WS50-ET09
12 Ft. Overhead Tool Crane	144" (3658)	50 lbs. (22.7 kg)	WS50-ET12
6 Ft. Overhead Tool Crane	72" (1829)	250 lbs. (113.6 kg)	WS60-ET06
12 Ft. Overhead Tool Crane	144" (3658)	250 lbs. (113.6 kg)	WS60-ET12

NOTE: For best results, tool rail width should not exceed six times the trolley wheelbase. Example: 24"(2 ft.) x 6 = 12 ft.

JIB KITS

BENCH OR FLOOR MOUNTED, 30 lb. CAPACITY

JIBS



Jib kits feature either fixed or swing booms mounted on vertical columns and are painted polyester beige. The boom may be adjusted vertically higher or lower on the column to suit your specific application. Vertical columns are typically 4 ft. (1.2m) for bench mounting and 7 ft. (2.1m) for mounting on the floor. If floor mounted, the optional support clamp (WS50-SC) fastened to wall or back of bench is recommended.

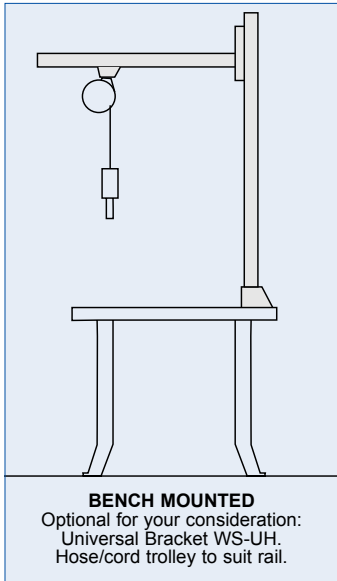

BENCH MOUNTED
Optional for your consideration:
Universal Bracket WS-UH.
Hose/cord trolley to suit rail.

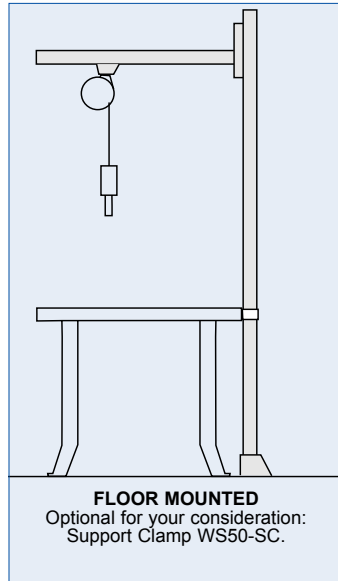

FLOOR MOUNTED
Optional for your consideration:
Support Clamp WS50-SC.

JIB KITS with W3F or W3S prefix include (1) 3' WS30 boom, (1) WS50 vertical column, (1) mounting base, (2) end caps, (1) end stop, (1) balancer trolley (1" hole diameters), and all hardware. Fixed booms are mounted to the vertical columns with angle brackets, also included.

ALL KITS include hardware needed for assembly. Fasteners for mounting base to bench top or floor not included.

Sizes and configurations other than those shown may be made-up by ordering individual components. Refer to other pages in this catalog.

These Jibs use WS30 Rail rated for loads up to 30 lbs. (13.5 kg)

BOOM LENGTH ft. (m)	BOOM TYPE	VERTICAL COLUMN ft. (m)	WGT lbs.	MODEL NUMBER
3.0 (0.9)	Swing	4.0 (1.2)	12	W3S-030400
3.0 (0.9)	Fixed	4.0 (1.2)	12	W3F-030400
3.0 (0.9)	Swing	7.0 (2.1)	21	W3S-030700
3.0 (0.9)	Fixed	7.0 (2.1)	21	W3F-030700

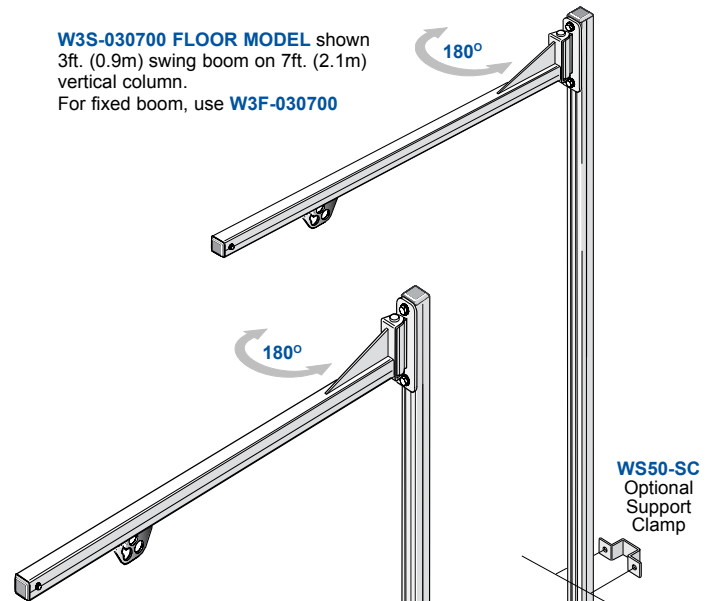

W3S-030700 FLOOR MODEL shown
3ft. (0.9m) swing boom on 7ft. (2.1m)
vertical column.
For fixed boom, use **W3F-030700**

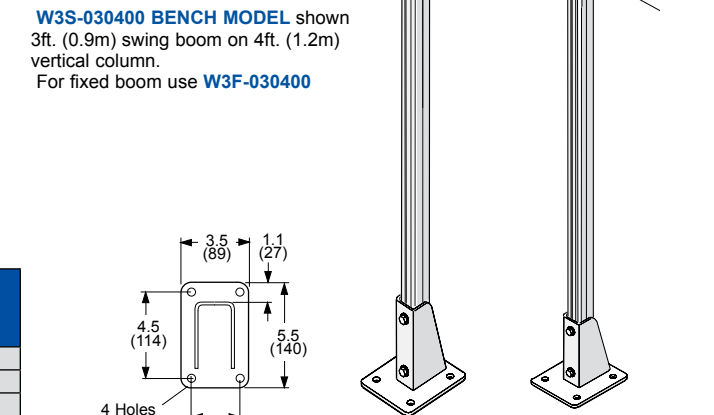

W3S-030400 BENCH MODEL shown
3ft. (0.9m) swing boom on 4ft. (1.2m)
vertical column.
For fixed boom use **W3F-030400**

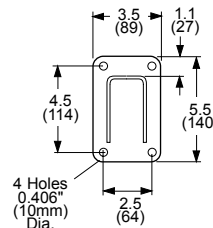

WS50-TB
MOUNTING BASE INCLUDED
Use Optional WS50-TBS Backing Plate

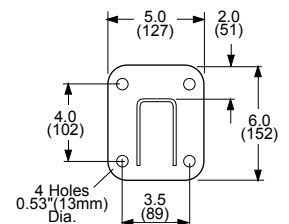

WS50-MB
MOUNTING BASE INCLUDED
Use Optional WS50-MBS Backing Plate



W3S-030400 BENCH MODEL
Shown with optional **WS-UH** Universal Bracket.
See page 24 for more accessories.



Jib Kits feature heavy duty I-beam booms or C-rail booms. 50 lb. capacity kits are painted beige polyester and are available with either fixed or swing (180°) booms up to 18' long. Columns available to 12' high. Booms may be mounted higher or lower on the column to suit your specific application. Booms are WS50 rail for loads up to 50 lbs. (22.5kg). Vertical columns include pre-drilled, gusseted mounting bases with 10" adapter plates now available for round columns. The Vertical columns are 3" O.D. x 2.5" I.D. (76mm x 64mm) welded steel tubing. Vertical column for 18' boom is 6" square steel tube with 3" dia. x 2' mounting shaft at top. Vertical columns for 50 lb. capacity jibs also available separately, see model chart.

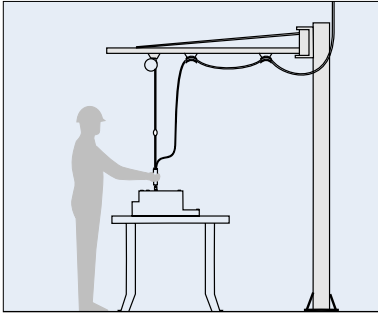

JIB KITS include (1) boom, (1) vertical column with integral mounting base (1) balancer trolley, (1) Hose/Cable Trolley, (1) End Clip, and all assembly hardware.

KIT NUMBERS assume festoon trolleys for typical 3/8" (9mm) I.D. hose with saddle to handle O.D. range of 0.60"-0.94" (15-24mm). If optional saddle with range of 0.31"-0.59" (08-15mm) is desired, substitute "1" for "2" as last digit of model number. Example: W5S-060301

MODEL CHART-HEAVY DUTY JIBS

BOOM LENGTH ft. (m)	BOOM TYPE	VERTICAL COLUMN ft. (m)	BASE TYPE	WGT lbs.	MODEL NUMBER	
6.0 (1.8)	Fixed	3.0 (0.9)	Round	W5	53	W5F-060302
6.0 (1.8)	Swing	3.0 (0.9)	Round	W5	53	W5S-060302
10.0 (3.0)	Fixed	3.0 (0.9)	Round	W5	81	W5F-100302
10.0 (3.0)	Swing	3.0 (0.9)	Round	W5	81	W5S-100302
6.0 (1.8)	Fixed	7.0 (2.1)	Round	W5	83	W5F-060702
6.0 (1.8)	Swing	7.0 (2.1)	Round	W5	83	W5S-060702
10.0 (3.0)	Fixed	7.0 (2.1)	Round	W5	111	W5F-100702
10.0 (3.0)	Swing	7.0 (2.1)	Round	W5	111	W5S-100702
6.0 (1.8)	Swing	8.0 (2.4)	Round	W5	90	W5S-060802
6.0 (1.8)	Fixed	9.0 (2.7)	Round	W5	98	W5F-060902
6.0 (1.8)	Swing	9.0 (2.7)	Round	W5	98	W5S-060902
10.0 (3.0)	Fixed	9.0 (2.7)	Round	W5	126	W5F-100902
10.0 (3.0)	Swing	9.0 (2.7)	Round	W5	126	W5S-100902
12.0 (3.6)	Swing	9.0 (2.7)	Round	W5	138	W5S-120902
18.0 (5.4)	Swing	12.0 (3.6)	**Square	W5S	373	W5S-181202

STOPS TO LIMIT BOOM SWING

Manual Boom Stop - Model W5S-SK. Spring Loaded Boom Stop - W5S-BMLK - 20" Release Rod & W5S-BMLK54 - 54" Release Rod. Both W5S-BMLKs include spring loaded lock, brackets and all hardware. All field installed only.



Many people want the flexibility a swing boom provides but need to limit swing in one or both directions. Two boom stops are available. One (below) has manually positioned (screw-in) stops that limit swing to 15°, 30°, 45°, or 60° in either direction. The other (left) has a spring loaded stop that, when pulled, allows the boom to swing freely throughout its normal 180° arc and, when released, lock it at the straight position or every 15° in either direction. Stops are easily installed on 50 lb. capacity swing booms without drilling or welding.

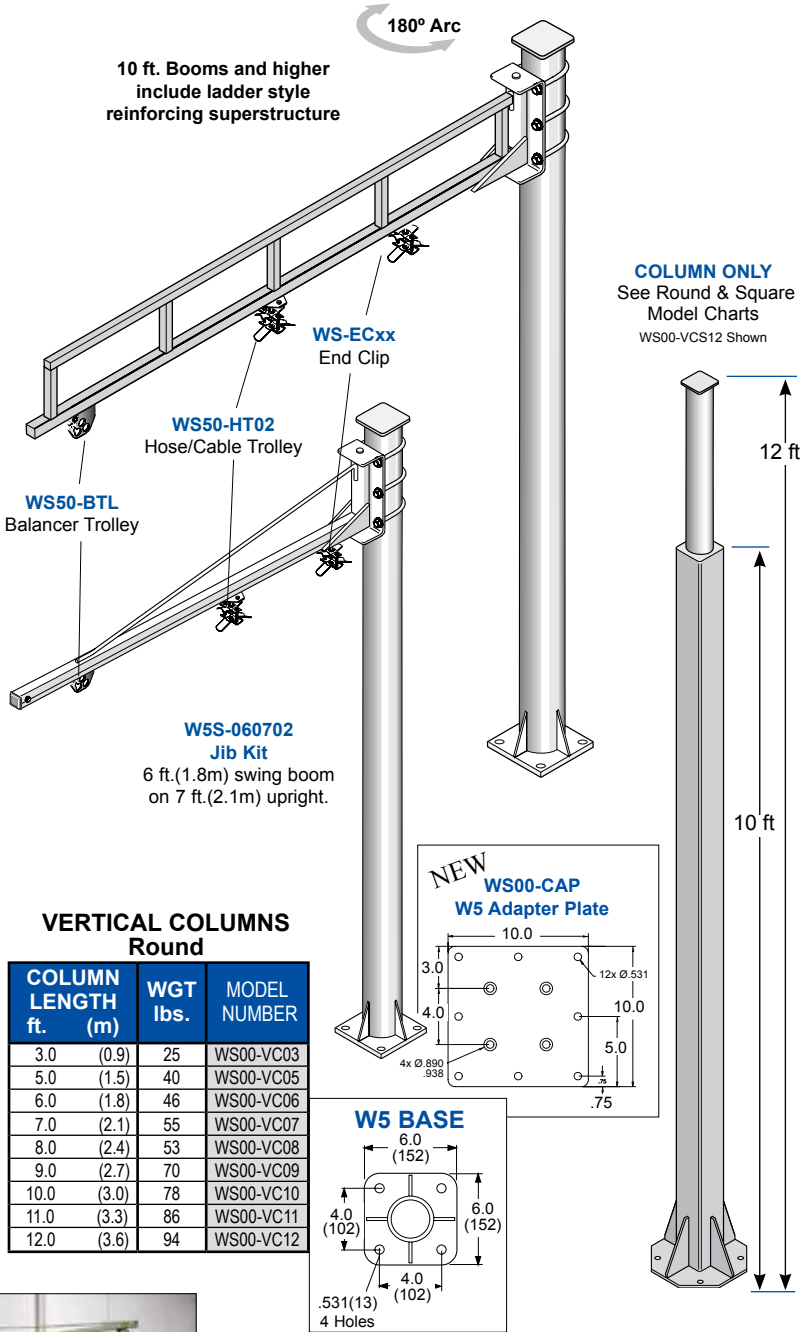

VERTICAL COLUMNS Round

COLUMN LENGTH ft. (m)	WGT lbs.	MODEL NUMBER
3.0 (0.9)	25	WS00-VC03
5.0 (1.5)	40	WS00-VC05
6.0 (1.8)	46	WS00-VC06
7.0 (2.1)	55	WS00-VC07
8.0 (2.4)	53	WS00-VC08
9.0 (2.7)	70	WS00-VC09
10.0 (3.0)	78	WS00-VC10
11.0 (3.3)	86	WS00-VC11
12.0 (3.6)	94	WS00-VC12

W5 BASE

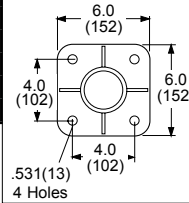

VERTICAL COLUMNS Square

COLUMN LENGTH ft. (m)	WGT lbs.	MODEL NUMBER
12.0 (3.6)		WS00-VCS12

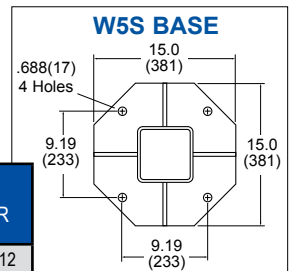

6' Boom Length Application - Shown with optional Hubbell Balancers (see page 8) over machining work area.

**May be used with any 50 lb. capacity boom.

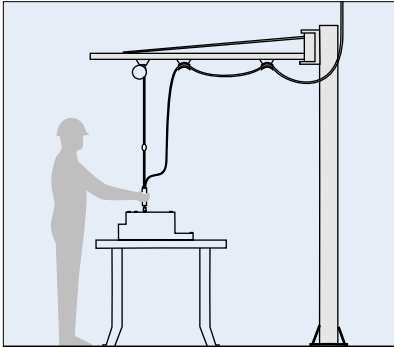

JIB KITS include (1) boom, (1) vertical column with integral mounting base, (1) balancer trolley, (2) festoon trolleys, (1) end clip, and all assembly hardware.

STOPS TO LIMIT BOOM SWING

Boom Stops – 150 lb. & 300 lb. Jibs - Model W6S-SK
 Consists of two machined steel stops (one for each direction and all required hardware. All field installed only.

When less than a full 360° swivel is desired on the 300 lb. capacity jib, add the Model W6S-SK stops. Swing Stop Kit consists of two machined steel stops (one for each direction) and all required hardware. Stops are RED for visibility.

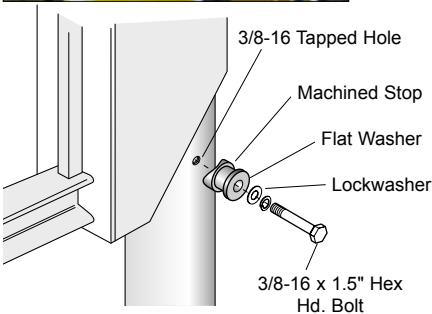

150 lb. & 300 lb. Jib Kits are painted yellow polyester.

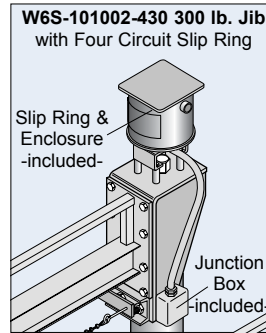
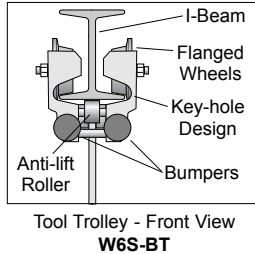

W6S-101002 300 lb. Capacity Jib Kit with Swivel Air Fitting

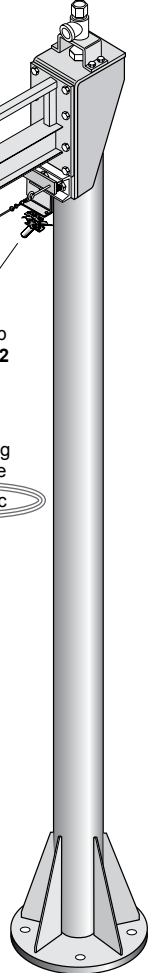
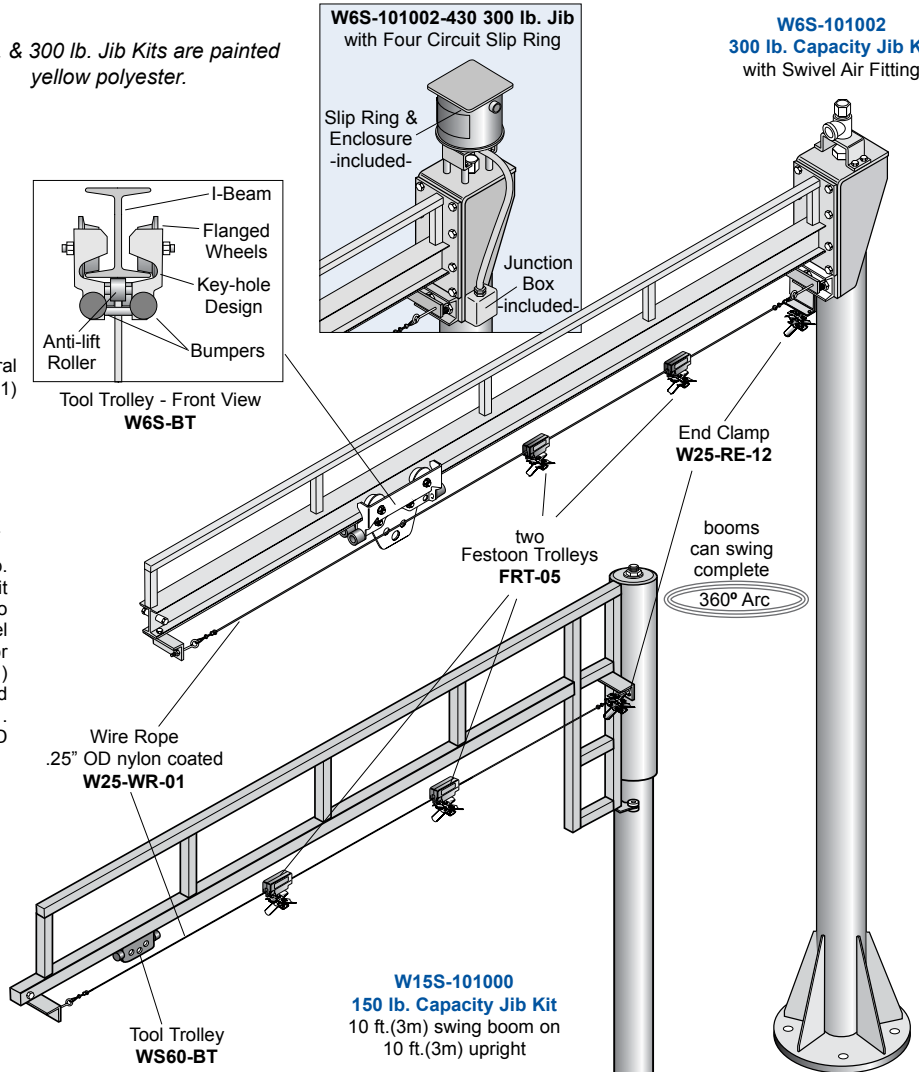

BOOM LENGTH ft. (m)	BOOM TYPE	VERTICAL COLUMN ft. (m)	WEIGHT lbs.	MODEL NUMBER
---------------------	-----------	-------------------------	-------------	--------------

150 lbs. (67.5kg) capacity Jib.

Boom is WS60 rail. Column is 4" schedule 40 steel pipe.

6.0 (1.8)	360° Swing	10.0 (3.0)	520	W15S-100600
8.0 (2.4)	360° Swing	10.0 (3.0)	535	W15S-100800
10.0 (3.0)	360° Swing	10.0 (3.0)	550	W15S-101000
* Full Rotation Stops			5	W6S-SK

300 lbs. (135kg) capacity Jib.

Boom is 3" I-beam. Vertical column is 6" schedule 40 steel pipe.

10.0 (3.0)	Pneumatic	10.0 (3.0)	640	W6S-101002
10.0 (3.0)	Electric	10.0 (3.0)	668	W6S-101002-430
I-Beam Trolley only - Fits 3"(76) I-beam			18	W6S-BT
* Full Rotation Stops			5	W6S-SK



Rotating 300 lb. Jib shown at end of multiple machine lines.

W15S & W6S BASE

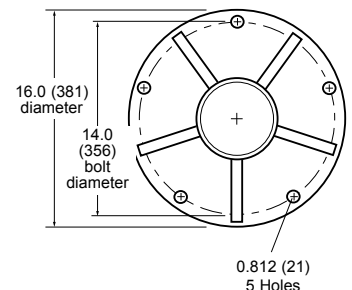

JIB KITS

CEILING MOUNTED, 50lb. CAPACITY JIB KITS

JIBS



Hanging a jib from an overhead structure may be the best way to put a workstation where it's needed. These kits free floor space and allow for greater plant layout flexibility. Jibs have steel WS50 booms in length shown. Vertical columns include a heavy duty 3ft. (0.9m) safety chain at the top and safety plate at the bottom to prevent boom from sliding off. The columns are 3" O.D. x 2.5" I.D. (76 x 64mm) welded steel tubing.

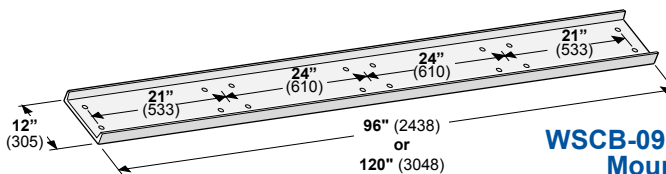
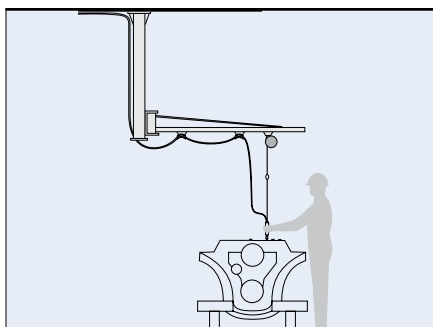

WSCB-096 & WSCB-120 Mounting Plate

Optional. Attaches to ceiling cross members for mounting jib to ceiling structures. Pre-drilled in three places to match jib base.

MOUNTING PLATE 12" x 96" (304 x 2438)	WSCB-096
MOUNTING PLATE 12" x 120" (304 x 3048)	WSCB-120

CEILING MOUNTED JIB KIT

Includes 6 ft.(1.8m) swing boom, vertical column with integral safety chain and safety plate, 3 U-bolts, 1 balancer trolley, 1 hose/cable trolley for festoon, 1 end stop and 1 end cap.

CEILING MOUNTED COLUMNS

Do not include booms but do include safety plate and integral safety chain.

BOOM AND TROLLEY DETAILS

Sizes and configurations other than those shown may be made-up by ordering individual components

Kit numbers listed assume typical 3/8" (9mm) I.D. hose with saddle to handle O.D. range of 0.60"-0.94" (15-24mm). If optional saddle with O.D. range of 0.31"-0.59" (08-15mm) is desired, substitute "1" for "2" as last digit of model number. Example: WCS-060301.

WS50 Rail Booms for loads up to 50 lbs. (22.5kg)

BOOM LENGTH ft. (m)	BOOM TYPE	VERTICAL COLUMN ft. (m)	MODEL NUMBER w/ BOOM	MODEL NUMBER w/o BOOM
6.0 (1.8)	Swing	3.0 (0.9)	WCS-060302	WS00-CC03
6.0 (1.8)	Swing	5.0 (1.5)	WCS-060502	WS00-CC05
6.0 (1.8)	Swing	6.0 (1.8)	WCS-060602	WS00-CC06
6.0 (1.8)	Swing	7.0 (2.1)	WCS-060702	WS00-CC07
6.0 (1.8)	Swing	8.0 (2.4)	WCS-060802	WS00-CC08
6.0 (1.8)	Swing	9.0 (2.7)	WCS-060902	WS00-CC09

W5S-SK Manual Boom Stop

Many people want the flexibility a swing boom provides but need to limit swing in one or both directions. The boom stop (below) has manually positioned (screw-in) stops that limit swing to 15°, 30°, 45°, or 60° in either direction. Stops are easily installed on 50 lb. capacity swing booms without drilling or welding.

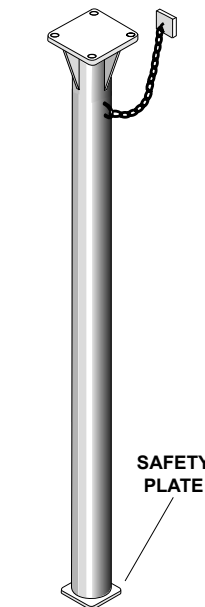

Ceiling Mounted Columns

Rugged 3.0" O.D. x 2.5" I.D. (76 x 64mm) welded steel tube. Beige polyester finish. Includes integral mounting base and 3' (0.9m) safety chain. Plate at bottom prevents equipment mounted on column from sliding off. Mounting hardware not included. See chart for model numbers.

USE: Supports tool rail booms or horizontal support members. Gets booms and tools up and out of the way, freeing floor space.

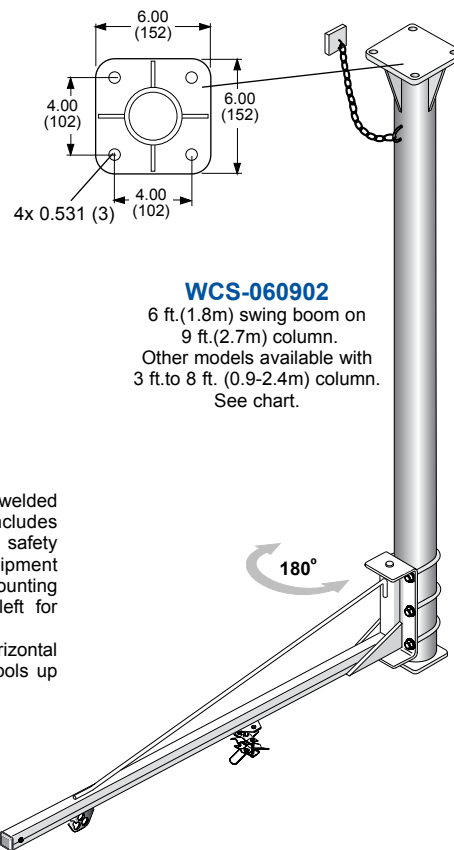

WCS-060902

6 ft.(1.8m) swing boom on 9 ft.(2.7m) column. Other models available with 3 ft. to 8 ft. (0.9-2.4m) column. See chart.

NEW!

HWS-FMK1 Kits for Mounting Fans to Ceiling Columns

Kit includes two U-Bolts and 13.50" w x 5.25" h Mounting Plate. End-user drills holes for fans. Column and fans are not included.



WS-UB

U-Bolt Assembly

Zinc plated steel
USE: Secures boom bracket or other flat plates to vertical column.
NOTE: Three required to mount boom.

ALUMINUM TRACK COMPONENTS

ADD TO OR BUILD YOUR OWN DESIGN

For loads up to 50 lbs. (22.5 kg)

COMPONENTS

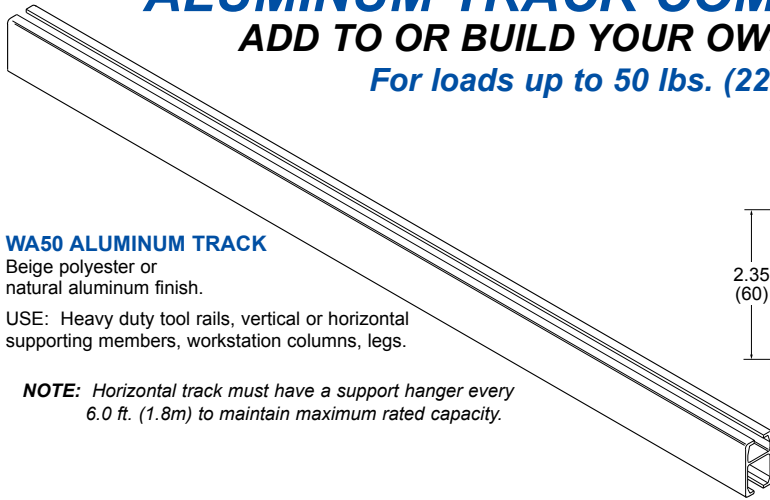

WA50 ALUMINUM TRACK

Beige polyester or natural aluminum finish.

USE: Heavy duty tool rails, vertical or horizontal supporting members, workstation columns, legs.

NOTE: Horizontal track must have a support hanger every 6.0 ft. (1.8m) to maintain maximum rated capacity.

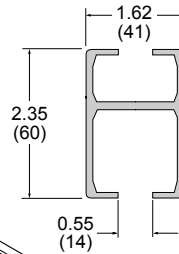

RAIL LENGTH ft. in. (m)	BEIGE MODEL NO.	NATURAL MODEL NO.
2' 5" (0.8)	WA50-T029	WA50-N029
3' 0" (0.9)	WA50-T036	WA50-N036
4' 0" (1.2)	WA50-T048	WA50-N048
5' 0" (1.5)	WA50-T060	WA50-N060
6' 0" (1.8)	WA50-T072	WA50-N072
7' 0" (2.1)	WA50-T084	WA50-N084
20' 0" (6.1)	N/A	WA50-N240
45° Angle Brace 1' 5" (0.4)	WA50-TB17	WA50-NB17

Consult factory for lengths not shown above.

Extruded aluminum rail features double tracks (top and bottom), one for trolleys and the other for mounting components or concealing hose or cable. Inside dimensions of the **larger track is same as WS50 steel rail** and fits standard WS50 trolleys, brackets, stops, etc. (following page). In addition, there is a full assortment of construction brackets, below, designed specifically for aluminum rail. **All mounting hardware included with brackets.** Brackets have black polyester finish with zinc plated steel hardware.

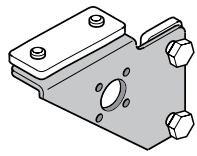

**WA-FBR
FRAMING BRACKET
RIGHT HAND**
USE: Attach rail perpendicular to rail. Mount electrical boxes or hose connectors.

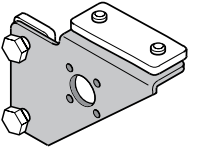

**WA-FBL
FRAMING BRACKET
LEFT HAND**
USE: Attach rail perpendicular to rail. Mount electrical boxes or hose connectors.

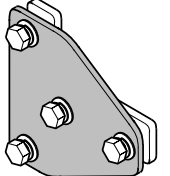

**WA-TP
T-PLATE**
USE: Use inside or outside. Install vertically or horizontally.

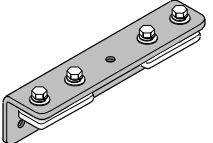

**WA-SA
SPLICE ANGLE**
USE: Designed to allow precise joining for unrestricted trolley movement.

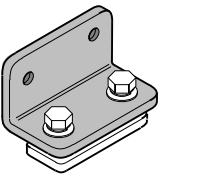

**WA-AMB
ANGLE MOUNTING
BRACKET**
USE: Hang rail to wall or other vertical support. Also attach sound boards, plywood to structures.

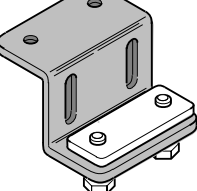

**WA-TMB
TOP MOUNTING
BRACKET**
USE: Attach top to bench.

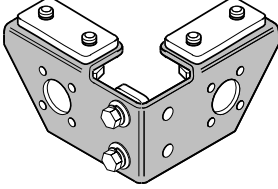

**WA-CB
CORNER BRACKET**
USE: Join three perpendicular rails.

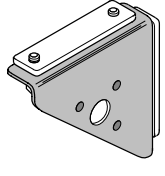

**WS-AB
ANGLE BRACKET**
USE: Join rails at right angles.

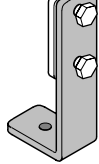

**WA-LF
LEVELER FOOT**
USE: Forms smooth foot. Adjust to level structure.

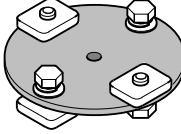

**WA-HD
HANGER DISK**
USE: Join crossing rails at right angles. Hang rails from other supports.

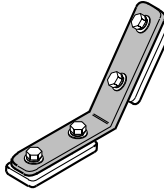

**WA-AB
ANGLE BRACE
BRACKET (45°)**
WA50-TB17
or
WA50-NB17
17" ALuminum Angle Brace
Cut 45° On Both Ends
(see chart above).

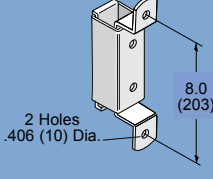

**WA50-MP
UNIVERSAL BASE**
Zinc plated steel
USE: Weld or bolt to new or existing benches or conveyors. Provides pocket for mounting WA50 column. Cannot be used with WS50 rail.

8.0 (203)
2 Holes .406 (10) Dia.

STEEL TRACK, 30 lb.

COMPONENTS



For loads up to 30 lbs. (13.5 kg)

RAIL LENGTH		MODEL NUMBER
ft.	(m)	
3.0	(0.9)	WS30-T03
4.0	(1.2)	WS30-T04
5.0	(1.5)	WS30-T05
6.0	(1.8)	WS30-T06
7.0	(2.1)	WS30-T07
8.0	(2.4)	WS30-T08
9.0	(2.7)	WS30-T09

Consult factory for lengths not shown above.

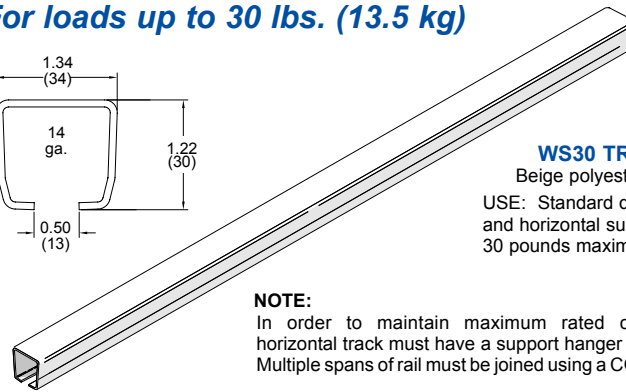
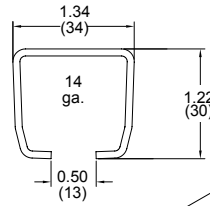

WS30 TRACK

Beige polyester finish.

USE: Standard duty tool rail and horizontal supports up to 30 pounds maximum load.

NOTE:

In order to maintain maximum rated capacity all WS30 horizontal track must have a support hanger every 6.0 ft. (1.8m). Multiple spans of rail must be joined using a COUPLER/HANGER.

Separate **TOOL RAIL COMPONENTS** allow you to quickly and inexpensively build your own work stations, retrofit existing stations or customize a kit. Finished as shown, all parts are the same high quality included with kits and guaranteed to be interchangeable. Components shown are designed for use with **WS30** rail. Starred (*) items may also be used with WS50 or extruded aluminum rails. **Mounting hardware, where required, is included.**

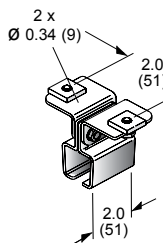

WS30-HG HANGER

Black polyester finish.
USE: Hang/support single spans of WS30 rail from **WS50, WA50 Extruded Aluminum** rail or other suitable support.

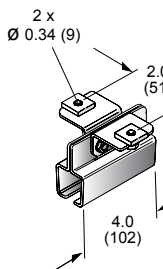

WS30-CH COUPLER/HANGER

Black polyester finish.
USE: Connects and hangs multiple spans of WS30 rail from **WS50, WA50 Extruded Aluminum** rail or other suitable supports

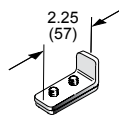

WS30-ES END STOP

Zinc plated steel.
USE: Keeps trolley movement within preselected limits.

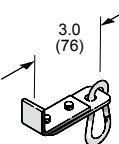

WS30-ESH END STOP HOOK

Zinc plated steel.
USE: Supports tool balancer. Also acts as end stop.

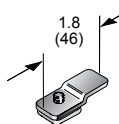

WS-HC* HOLDOWN CLIP

Black polyester finish.
USE: Affixes conveyors and other machines to top of rail.

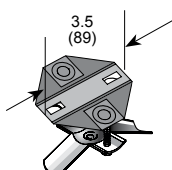

WS-EC01* 0.31 - 0.59 O.D. (Ø8 - 15mm)

WS-EC02* 0.60 - 0.94 O.D. (15 - 24mm)

END CLAMP ASSY

USE: Supports hose/cable and prevents trolley overtravel.

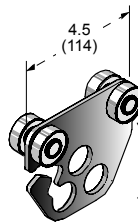

WS30-BTL BALANCER TROLLEY

Black polyester finish.
USE: Moving support for tool balancers, etc. Runs in WS30 tool rail.



WS30-BTS SINGLE ROLLER BALANCER TROLLEY

Black polyester finish.
USE: Tool balancer trolley. Runs in WS30 tool rail.

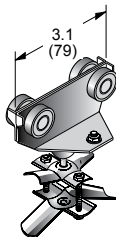

WS30-HT01* 0.31 - 0.59 O.D. hose (Ø8 - 15mm)

WS30-HT02* 0.60 - 0.94 O.D. hose (15 - 24mm)

HOSE/CABLE TROLLEY

Black polyester finish.
USE: Moving cable/hose clip.

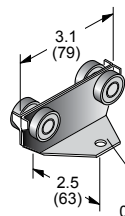

WS30-03TP PLAIN TROLLEY

Black polyester finish.
USE: Utility trolley

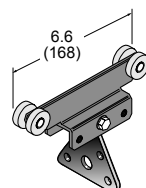

WS30-SPT SWING PLATE TROLLEY

Black polyester finish.
USE: Designed for use with Hose-Hider but also works extremely well alone. Swinging tool hook aids lateral movement.

WS30-TB BENCH MOUNT

Black polyester finish.

USE: Mounting WS30 rail vertically to bench top.

WS30-TBS Backing Plate Optional (Use beneath mounting surface.)

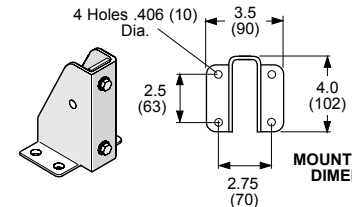

MOUNTING BASE DIMENSIONS



WS30-TN* TRACK NUT

Zinc plated steel.
USE: Attaches fixed components to rail.

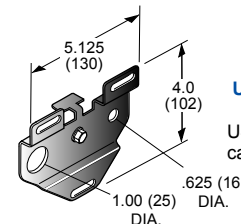

WS-UH* UNIVERSAL BRACKET

Black polyester finish.
USE: Supports hose or cable, peg board, etc.

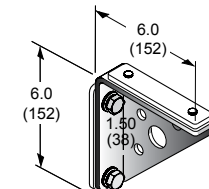

WS-AB* ANGLE BRACKET

Black polyester finish.
USE: Mounts horizontal tool rail to vertical column.

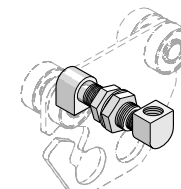

WS00-CH* 90° CONNECTOR

Brass. For 3/8"(9mm) hose.
USE: Attach hose to balancer trolley or various brackets.

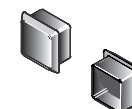

WS30-EP END CAP

Black molded vinyl.
USE: Caps off ends of rail for a finished look.

COMPONENTS



RAIL LENGTH		MODEL NUMBER
ft.	(m)	
3.0	(0.9)	WS50-T03
4.0	(1.2)	WS50-T04
5.0	(1.5)	WS50-T05
6.0	(1.8)	WS50-T06
7.0	(2.1)	WS50-T07
8.0	(2.4)	WS50-T08
9.0	(2.7)	WS50-T09
10.0	(3.0)	WS50-T10
12.0	(3.6)	WS50-T12

STEEL TRACK, 50 lb.

For loads up to 50 lbs. (22.5 kg)

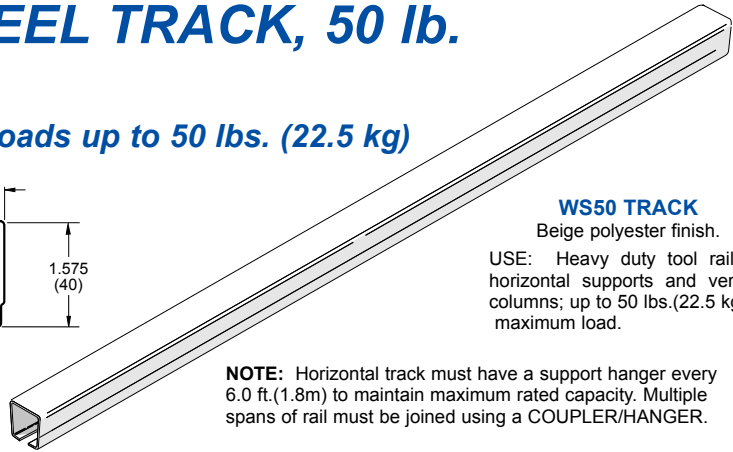
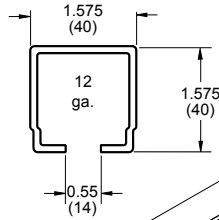

WS50 TRACK

Beige polyester finish.

USE: Heavy duty tool rail for horizontal supports and vertical columns; up to 50 lbs.(22.5 kg) maximum load.

NOTE: Horizontal track must have a support hanger every 6.0 ft.(1.8m) to maintain maximum rated capacity. Multiple spans of rail must be joined using a COUPLER/HANGER.

Consult factory for lengths not shown above.

Separate TOOL RAIL COMPONENTS allow you to quickly and inexpensively build your own work stations, retrofit existing stations or customize a kit. Finished as shown, all parts are the same high quality included with kits and guaranteed to be interchangeable. All mounting hardware is included.

All components below fit WS50 track. Items outside blue box may also be used with WA50 Extruded Aluminum Track.

WS50-HG HANGER
Black polyester finish.
USE: Hangs single spans of WS50 track from WS50 or WA50 rail and other suitable supports. **Cannot be used to hang WA50 track.**

WS50-CH COUPLER/HANGER
Black polyester finish.
USE: Connects and hangs multiple spans of WS50 track from WS50 or WA50 rail and other suitable supports. **Cannot be used to hang WA50 track.**

WS50-MP UNIVERSAL BASE
Zinc plated steel
USE: Weld or bolt to new or existing benches or conveyors. Provides pocket for mounting WS50 column. Cannot be used with WA50 rail.

WS50-BTL BALANCER TROLLEY
Black polyester finish.
USE: Moving support for tool balancers, etc. Runs in WS50 or WA50 tool rail.

WS50-BTS SINGLE ROLLER BALANCER TROLLEY
Black polyester finish.
USE: Tool balancer trolley. Runs in WS50 or WA50 tool rail.

WS00-CH 90° CONNECTOR
Brass. For 3/8"(9mm) hose.
USE: Attach hose to balancer trolley or various brackets.

WS50-10HR ROLLING HANGER
Black polyester finish.
USE: Supports tool rail beneath track to provide six way tool positioning. Runs in WS50 steel or WA50 aluminum rail. **Hanger will support WS50 track only.**

WS50-06TP
A=6.25 (158)
WS50-10TP
A=10.0 (254)
PLAIN TROLLEY
Black polyester finish.
USE: Utility trolley. Runs in WS50 OR WA50 rail.

WS50-HT01
0.31 - 0.59 O.D. hose (08 - 15mm)
WS50-HT02*
0.60 - 0.94 O.D. hose (15 - 24mm)
HOSE/CABLE TROLLEY
Black polyester finish.
USE: Moving cable/hose clip. Runs in WS50 or WA50 tool rail.

WS50-SPT SWING PLATE TROLLEY
Black polyester finish.
USE: Designed for use with Hose-Hider but also works extremely well alone. Swinging tool hook aids lateral movement. Runs in WS50 OR WA50 tool rail.

WS-AB ANGLE BRACKET
Black polyester finish.
USE: Mounts horizontal tool rail to vertical column.

WS50-TN TRACK NUT
Zinc plated steel.
USE: Attaches fixed components to rail. Slides in from rail end.

WS50-EZTN E-Z NUT
Zinc plated steel.
USE: Attaches fixed components to rail, from front.

WS50-HBS HOOK BRACKET SET (2)
Black polyester finish.
USE: Hang rod to hold rolls of wrap, wire, etc.

WS50-HR03 (04) (05) (06) HANGER ROD
5/8" O.D. X 3/8" I.D. unfinished steel tube in length (ft.) shown

WS-UH UNIVERSAL BRACKET
Black polyester finish.
USE: Supports hose or cable, peg board, etc.

WS50-TB BENCH MOUNT
Beige polyester finish.

WS50-ES END STOP
Zinc plated steel.
USE: Keeps balancer trolley movement within preselected limits.

WS50-ESH END STOP HOOK
Zinc plated steel.
USE: Supports tool balancer. Adjustable location. Also acts as end stop.

WS-EC01
0.31 - 0.59 O.D. (08 - 15mm)
WS-EC02
0.60 - 0.94 O.D. (15 - 24mm)
END CLAMP ASSY
USE: Supports hose/cable and prevents trolley overtravel.

WS50-EP END CAP
Black molded vinyl.
USE: Caps off ends of rail.

WS50-TN TRACK NUT
Zinc plated steel.
USE: Attaches fixed components to rail. Slides in from rail end.

WS50-EZTN E-Z NUT
Zinc plated steel.
USE: Attaches fixed components to rail, from front.

WS50-HBS HOOK BRACKET SET (2)
Black polyester finish.
USE: Hang rod to hold rolls of wrap, wire, etc.

WS50-HR03 (04) (05) (06) HANGER ROD
5/8" O.D. X 3/8" I.D. unfinished steel tube in length (ft.) shown

WS-UH UNIVERSAL BRACKET
Black polyester finish.
USE: Supports hose or cable, peg board, etc.

WS50-TB BENCH MOUNT
Beige polyester finish.

WS50-TBS Backing Plate
Backing Plate (Same size as Mounting Base) Optional

WS50-MB FLOOR MOUNT
Black polyester finish.

WS50-MBS Backing Plate
Backing Plate (Same size as Mounting Base) Optional

MOUNTING BASE DIMENSIONS

MOUNTING BASE DIMENSIONS



Fixed or 180° Swinging WS50 Booms

USE: Wall or column mounted tool rail; or use two fixed booms as support for horizontal tool rail. (Cross rail and hangers not included). End stop and end cap included. *Eight foot (2.4m), ten foot (0.3m) and 18 foot (5.4m) booms include ladder style reinforcing superstructure. Trolley extra. Beige polyester finish.

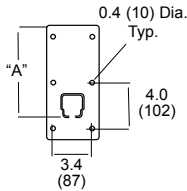

TYPE	Dim. A in. (mm)
Swing	8.12 (206)
Fixed	7.75 (197)

MOUNTING HOLE LAYOUT 4'-10' BOOMS

MOUNTING HOLE LAYOUT 18' BOOM

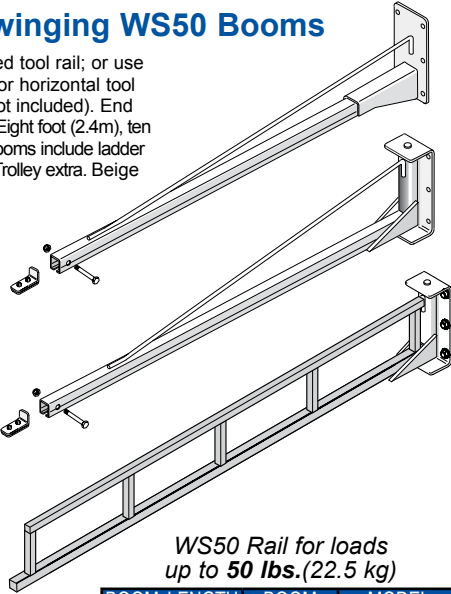
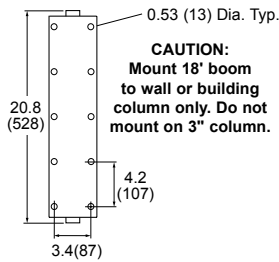

WS50 Rail for loads up to 50 lbs.(22.5 kg)

BOOM LENGTH ft. (m)	BOOM TYPE	MODEL NUMBER
4.0 (1.2)	Fixed	WF50-WS04
4.0 (1.2)	Swing	WS50-WS04
6.0 (1.8)	Fixed	WF50-WS06
6.0 (1.8)	Swing	WS50-WS06
8.0* (2.4)	Fixed	WF50-WS08
8.0* (2.4)	Swing	WS50-WS08
10.0* (3.0)	Fixed	WF50-WS10
10.0* (3.0)	Swing	WS50-WS10
12.0* (3.7)	Swing	WS50-WS12
18.0* (5.4)	Swing	WS50-WS18

*Features ladder style reinforcing rather than tie rod. Model WS50-WS18 has stacked (doubled) rail for additional strength.

WS-UB U-BOLT ASSEMBLY

USE: Secures 4'-10' booms or other flat plates to 3" dia. vertical column. Three are required to mount boom onto vertical column. Do not use for mounting 18' boom (#WS50-WS18). Zinc plated steel.

Rail Mounted Fixed or Swing Booms

USE: Tool rail mounted to WS50 or WA50 vertical column. End stop, end cap, safety bolt and all hardware included. Trolley extra. Beige polyester finish.

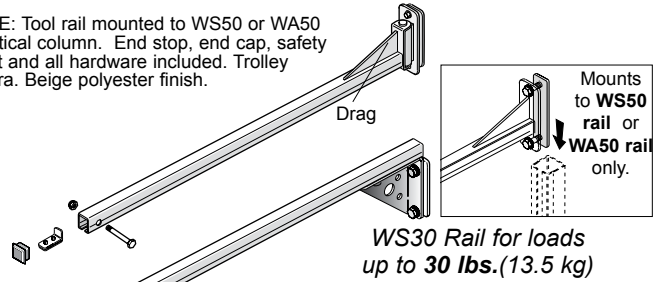

WS30 Rail for loads up to 30 lbs.(13.5 kg)

BOOM LENGTH ft. (m)	BOOM TYPE	MODEL NUMBER
3.0 (0.9)	Fixed	WF30-DS03
3.0 (0.9)	Swing	WS30-DS03
4.0 (1.2)	Swing	WS30-DS04

Wall Mounted Booms

USE: Wall mounted tool rail. End stop, end cap and safety bolt included. Trolley extra. Beige polyester finish.

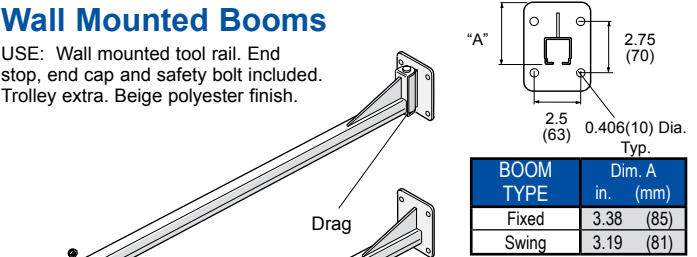

BOOM TYPE	Dim. A in. (mm)
Fixed	3.38 (85)
Swing	3.19 (81)

WS30 Rail for loads up to 30 lbs.(13.5 kg)

BOOM LENGTH ft. (m)	BOOM TYPE	MODEL NUMBER
3.0 (0.9)	Fixed	WF30-WS03
3.0 (0.9)	Swing	WS30-WS03
4.0 (1.2)	Fixed	WF30-WS04
4.0 (1.2)	Swing	WS30-WS04

BASES AND SUPPORTS

These bases are larger than those listed with the track components and are used primarily when a more rigid structure is desired. All bases include all hardware for mounting rail to base.

BENCH LEG BASE

USE: Mounts workstation to bench by providing a "pocket" into which WS50 track may be fitted. Models for 30"(762) or 36"(914) deep benches. Universal hole pattern in foot plus adjustable "Joiner Plate Box" provide solid grip to the bench leg. Includes hardware required for mounting rail to base. Does not include hardware required to mount base to bench. Joiner plate box included and also available separately. Black polyester finish.

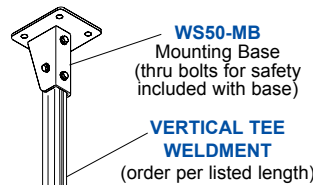
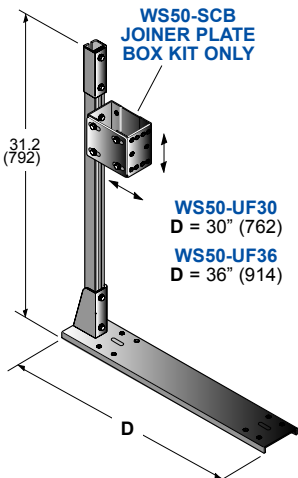

Model Number	Length
62829003	3 ft.
62829006	6 ft.
62829008	8 ft.
62829009	9 ft.
62829010	10 ft.
62829011	11 ft.
62829012	12 ft.

WS50 VERTICAL HANGER SUPPORT ASSEMBLY KIT

Hanging a tool rail safely from an overhead structure may be the best way to put a workstation where it's needed. These kits consist of a 12" long cross rail section welded to a 3 ft., 6 ft. or 9 ft. vertical rail section and a WS50-MB Mounting Base. These 50 lb. capacity hangers are for use with WS50 steel track and are sold only as kits. Tool track must be supported every six feet to preserve 50 lb. capacity rating.

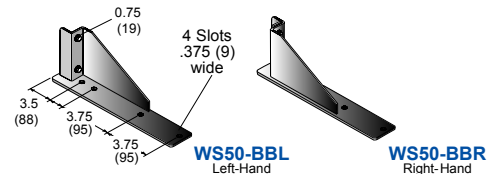
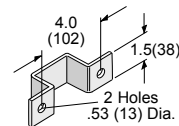

TABLE BRACKETS

USE: Mounts WS50 or WA50 vertical support columns to typical work bench. Provides greater rigidity when mounted to sheet metal tops than standard bases. For even greater strength, use model #WS50-BBS backing plate (optional) beneath bench top. Includes hardware for mounting rail to bracket. Does not include hardware for mounting base to bench. Black polyester finish.



SUPPORT CLAMP

WS50-SC-For WS50 (steel) Rail WA50-SC-For WA50 (Aluminum) Rail

USE: Fasten rail to back of bench for added stability. Typically used with WS50-MB base. Black polyester finish.

WS60-SC-For WS60 (steel) Rail also available. Mounting dimensions differ from WS50-SC.



RETRIEVER REELS are designed to provide a "constant" pulling force over a specified distance. Working length (in feet) and pull (in pounds) shown in chart below. Reels feature rugged steel construction with polyester baked finish and rigid mounting bracket. Spring is permanently lubricated. Cable is 920 lb. (414kg) test 0.09" (2.3mm) dia. 7 x 7 strand galvanized steel aircraft cable nylon covered to 0.12" (3.0mm) O.D. Reels include end clip and adjustable cable stop. Net weight of all models 10 lbs. (4.5kg).

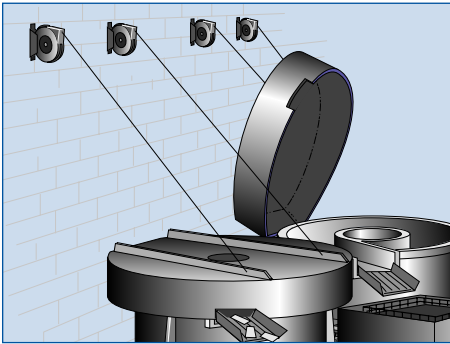

Sound dampening covers on vibrating cleaners make sound level in a metal finishing plant more acceptable. Two RETRIEVERS lift part of each cover's weight and make opening easier and safer.

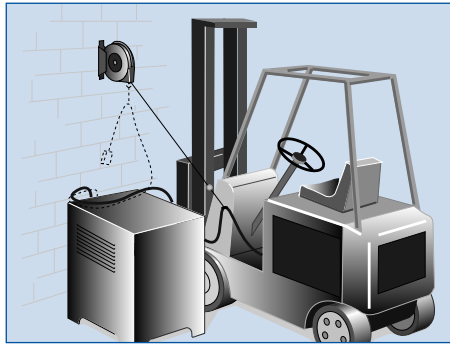

RETRIEVER keeps fork truck charging cables out of the way when not in use, reducing damage and need for costly replacement. Mount retriever on wall, as shown here, or directly on charger.

APPLICATION
RETRIEVER REELS are available in two mounting types: (A) with pull parallel to mounting surface. (B) with pull perpendicular to mount. Choose type which provides payout in direct line to attachment.

DIMENSIONS

ALL DIMENSIONS IN INCHES (mm)

"A" MOUNT-SERIES TQR

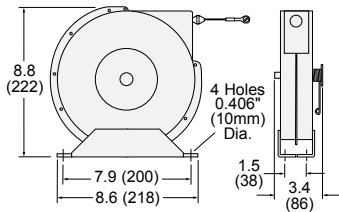

"B" MOUNT-SERIES TQV

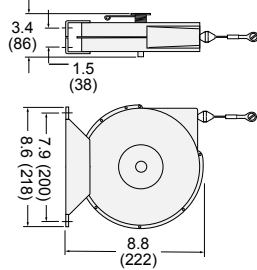

WORKING LENGTH CHART

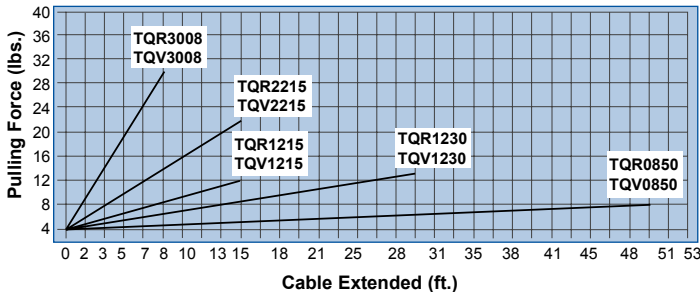

SELECTION CHART

CABLE LENGTH ft. (m)	MINIMUM PULL** lbs. (kg)	MAXIMUM PULL** lbs. (kg)	"A" MOUNT MODEL NO.	"B" MOUNT MODEL NO.
50 (15.0)	0.5 (0.2)	7.5 (3.4)	TQR0850	TQV0850
15 (4.5)	3.0 (1.4)	12.0 (5.4)	TQR1215	TQV1215
30 (9.0)	3.0 (1.4)	12.0 (5.4)	TQR1230	TQV1230
15 (4.5)	7.5 (3.4)	22.0 (9.9)	TQR2215	TQV2215
8 (2.4)	8.0 (3.6)	30.0 (13.5)	TQR3008	TQV3008

*Cable lengths listed are for "active" or "working" cable. Includes end clip and cable stop.
**Pulling forces above are approximate and depend on exact spring adjustment or pre-tensioning by the user. Reels are pre-set at the factory at the minimum pull. Adjusting reel to suit application is user's responsibility.

Packaging Workstation

Speed your shipments out the door. Shipping station kit was designed with utility and flexibility in mind. Strong, light weight extruded aluminum frame with steel joining brackets and maple bench tops may be assembled in a variety of configurations to fit your space and job requirements. Adjustable light with two 48" fluorescent lamps, packaging foam dispenser with cutting bar, adjustable shelf, power strip and swing arm mounted monitor and printer trays are included as standard. Unique wire trough on back helps organize and protect sensitive computer cables, power cords, etc. Station measures 120" long x 32.5" deep x 87" high in configuration shown. All metal parts have durable polyester finish. Aluminum is beige, steel brackets are matte black. All hardware is zinc plated steel.

DESCRIPTION	MODEL NO.
30" deep Packaging Workstation	HWS-ST120



NOTE: MONITOR, KEYBOARD, MOUSE, BAR CODE PRINTER, LABEL PRINTER AND OTHER SIMILAR EQUIPMENT ARE NOT INCLUDED

MINIMIZE REACHING FOR PARTS

SOLVE PARTS LOGISTICS PROBLEMS

MOBILE KITS



Here are three ways to supply small parts to the workstation in an ergonomically friendly manner. Properly positioned parts bins at assembly points minimize stretching and reaching which can lead to injuries. These carts are also great at temporary job task locations.

Place 'n Pick SHELF CART

Complete kits with three 12" (305mm) deep adjustable shelves are available in 30" (762mm), 42" (1067mm), 54" (1372mm), or 66" (1676mm) widths. Or, if you want to build a custom cart, frame kits allow you to install 12" (305mm) or 18" (457mm) deep shelves and other accessories like Bin Bars on which to hang bins, electric power strips or air manifolds, even swing arms (see workstation accessory page in this catalog). Maximum capacity 50 lbs. (22.5 kg) per shelf.

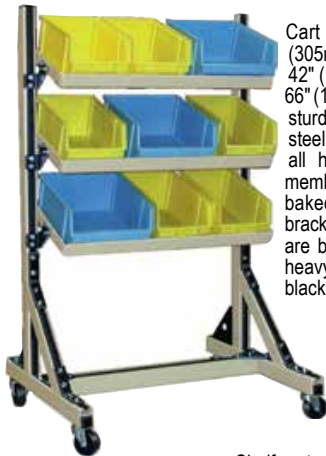

Cart kits include three 12" (305mm) deep x 30" (762mm), 42" (1067mm), 54" (1372mm) or 66" (1676mm) wide steel shelves, sturdy extruded aluminum frame, steel construction brackets, and all hardware. Aluminum frame members and shelves have beige baked polyester finish. Steel brackets, including shelf brackets, are black. Also included are four heavy-duty locking casters, and black end caps.



Shelf carts can easily handle many bin boxes of various sizes. Bins (not included) may be loaded onto shelves from front or rear.

SHELF CART KIT & COMPONENT LISTING

DESCRIPTION	MODEL NO.
Complete Cart Kit-(3) 12"D x 30"W Shelves included	HWP-SC30
Complete Cart Kit-(3) 12"D x 42"W Shelves included	HWP-SC42
Complete Cart Kit-(3) 12"D x 54"W Shelves included	HWP-SC54
Complete Cart Kit-(3) 12"D x 66"W Shelves included	HWP-SC66
INDIVIDUAL COMPONENTS	
Frame Kit*-For 30" Wide Shelves	HWP-SC03
Frame Kit*-For 42" Wide Shelves	HWP-SC04
Frame Kit*-For 54" Wide Shelves	HWP-SC05
Frame Kit*-For 66" Wide Shelves	HWP-SC06
Shelf-12"D x 30"W	WS50-SS03
Shelf-12"D x 42"W	WS50-SS04
Shelf-12"D x 54"W	WS50-SS05
Shelf-12"D x 66"W	WS50-SS06
Shelf-18"D x 30"W	WS50-SS183
Shelf-18"D x 42"W	WS50-SS184
Shelf-18"D x 54"W	WS50-SS185
Shelf-18"D x 66"W	WS50-SS186

*Frame kits include aluminum and steel members, four locking casters, end caps and all assembly hardware. Width shown is inside-to-inside dimension. Shelves fit inside frame uprights. Shelves that hang in front of uprights are available. See catalog for details on shelves and other accessories that can be easily installed on frame.

Rolling Bin Rack



Hang bin boxes on both sides, position cart in the best place for greatest workplace efficiency and ergonomics. Move easily if task or worker changes. Six bin supports may be positioned at desired heights. Bin boxes not included.

- Sturdy extruded aluminum frame with heavy-duty steel brackets.
- Includes six bars for holding bin boxes
- Four locking, swivel casters.
- 300 lb. max capacity.

Dimensions:
77"H x 36"D x 33.6" wide

DESCRIPTION	MODEL NO.
Bin Box Cart with four casters	HWP-BC01

Gravity Feed Rack



Semi-permanent (adjustable glides, not casters) designed for supplying parts bins to work areas. Two conveyor levels, each featuring four roller strips, fully adjustable slope and height. Sturdy steel stops prevent bin run-off. Roller strips supported along entire length by WS30 rail.

- Sturdy extruded aluminum frame with heavy-duty steel brackets.
- Adjustable glides, not casters.
- 300 lb. max capacity.

Dimensions:
62"H x 36"D x 30" wide

DESCRIPTION	MODEL NO.
Gravity Feed Rack with Glides	HWP-GFR

Supply 'n Return™ Gravity Feed Cart



Three adjustable conveyors supply full bins to assembly area and return empty bins to aisle. Each level may be easily adjusted for optimum slope and spacing. May also be assembled with all three levels sloped toward work area. Adjustable safety yellow bin stops also protect ends of conveyors. Tough baked polyester finish. Optional adjustable side guides (not shown) may be added to keep bins aligned. Bins not included.

- Sturdy extruded aluminum frame with heavy-duty steel brackets.
- 18 adjustable roller strips.
- 300 lb. max capacity.
- Locking, swivel casters

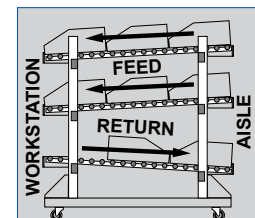

Dimensions:
48"H x 48"D x 47" wide

DESCRIPTION	MODEL NO.
Supply 'n Return Cart	HWP-GF444
Side Guides (set of two)	HWP-SG4



Push 'n Place™ WORKSTATION

Here's a way to maintain flexibility on the plant floor without sacrificing safety and productivity. The Hubbell Workplace Solutions Push 'n Place portable workstation rolls easily on four heavy-duty locking, swivel casters. Constructed of strong extruded aluminum rail, it measures 36" deep and 90" high, including casters. Frame is 44" wide o.c., perfect for under a 5' conveyor section or 60" bench. Tool bar is 60" long and can be fitted with splice angles to adjoin two or more units. Bin Bar, air manifold and balancer trolley with fitting plus 3/8" hose are standard. Frame is finished with beige baked polyester. Brackets are matte black. Assembly required.

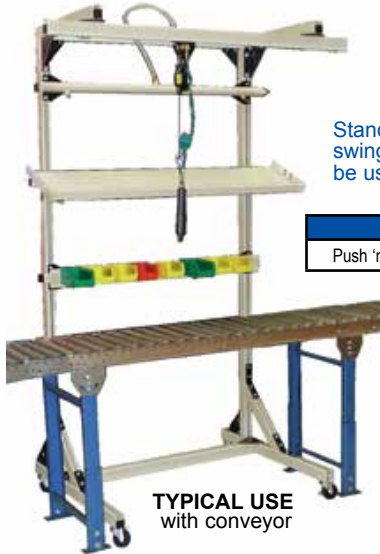

TYPICAL USE
with conveyor

NOTE:
Standard Hubbell Workplace Solutions swing arms and other accessories may be used with this portable workstation.

DESCRIPTION	MODEL NO.
Push 'n Place portable workstation	HWP-0475

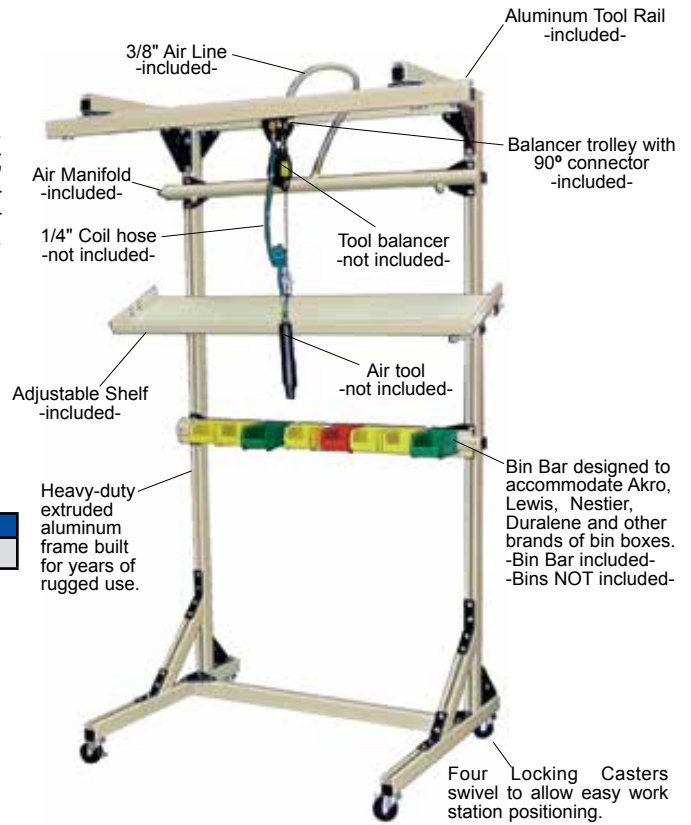

WIRE SPOOL CART

Here's the answer to production or maintenance wiring jobs. Roll the wire to the job, unspool what you need, and return the cart to a convenient storage place. WA50 aluminum rail with formed steel brackets, cart measures 54" high, 36" deep and 33.6" wide with a 27" clear space between spool shaft brackets, which are fully adjustable. Available with four heavy-duty casters (two fixed and two swivel with locks), two fixed casters and two glides or, for semi-permanent installation, with four glides. Swivel casters may be installed at either front or back. All components, except hardware, finished with chip-resistant baked polyester coating. Rails are beige and brackets are black. Assembly required. MAXIMUM CAPACITY: 300 lbs.

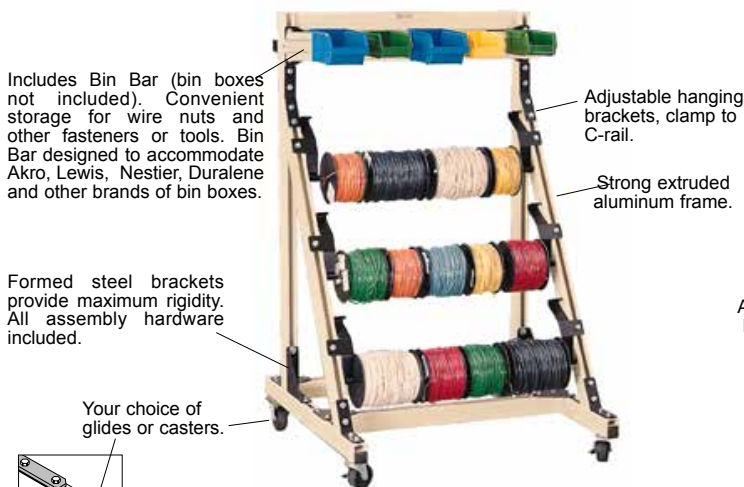

DESCRIPTION	MODEL NO.
Wire spool cart with four casters.	HWP-RC01
Wire spool cart with four glides.	HWP-RC02
Wire spool cart with two fixed casters and 2 glides.	HWP-RC03

OPTIONAL GLIDES

MOBILE TEST STATION

The Model HWP-TC01 Test Bed Cart represents the ultimate in versatility. Dual support rails adjust to any size electrical box. Box mounts easily with exclusive **EZ-NUT™** Track Nuts, furnished. Two coil hangers keep cable off floor while cart is being rolled to the job. Heavy duty shelf easily supports even the heaviest technical manuals. Bin Bar holds box bins for miscellaneous storage. Frame is strong extruded aluminum with beige baked polyester finish. All joining brackets are heavy steel with matte black polyester. Includes four locking, swivel casters and all assembly hardware. Bin boxes, electrical box and cables not included. Some assembly required.

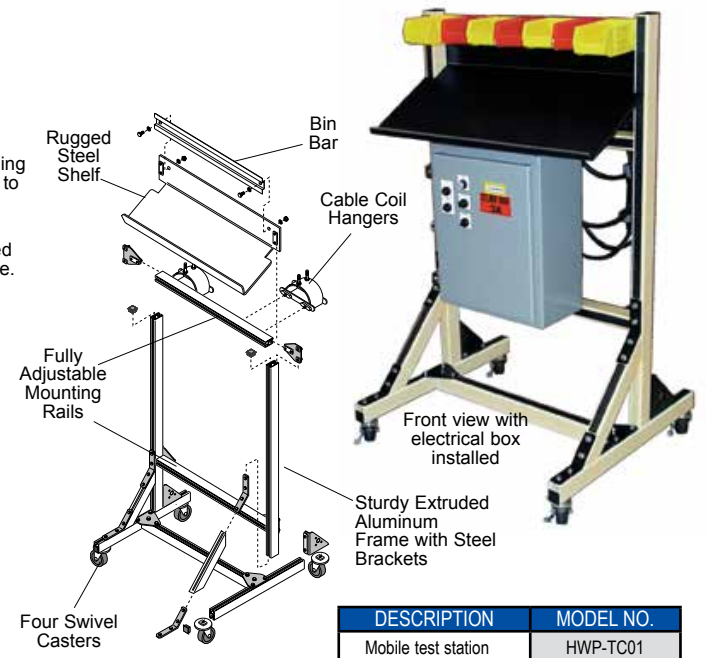

DESCRIPTION	MODEL NO.
Mobile test station	HWP-TC01

ORGANIZE YOUR WORK SITE

INFORMATION, DOCUMENTATION & INSPECTION STANDS



DOCUMENT PROTECTOR with FLEXIBLE ARM

DOCUMENT PROTECTORS

Available with "A" size 8.5" x 11" (portrait orientation) sheet protectors. Steel protector frames are mounted on an 18" flexible arm with clamp that can be easily affixed to desk top or table. Wall mount units include mounting screws and anchors.

Description	Ship Wgt.	Model Number
"A" size-18" Flexible Arm Mount w/10 pages (yellow pockets)	5 lbs	A700
"A" size-18" Flexible Arm Mount w/20 pages (yellow pockets)	6 lbs	A720
"A" size-18" Flexible Arm Mount w/30 pages (yellow pockets)	7 lbs	A730
"A" size-Wall Mount w/10 pages (yellow pockets)	5 lbs	A700W
"A" size-Wall Mount w/20 pages (yellow pockets)	6 lbs	A720W
"A" size-Wall Mount w/30 pages (yellow pockets)	7 lbs	A730W



WALL MOUNTED DOCUMENT STAND

WALL or BENCH MOUNTED DOCUMENT STAND

Features yellow high impact polystyrene document holder and writing surface on heavy duty steel support. Mounts easily to wall or bench top. Includes two clips. 9" x 13" writing surface has hinged, clear plastic document protector. Panels are yellow high impact polystyrene.

Description	Ship Wgt.	Model Number
Bench Mounted Document Stand	13 lbs.	A800B
Wall Mounted Document Stand	13 lbs.	A800W



13"x 20" DOCUMENT STAND

DOCUMENT STAND

Features two 20"W x 13"H panels; a document display board with two clips above an inclined writing surface. Writing surface includes two clips and hinged, clear document protector. Heavy-duty steel stand has three glides. Writing surface is 38" high. Overall height 61". Panels are yellow high impact polystyrene. Also available as wall mounted unit similar to A800W, left.

Description	Ship Wgt.	Model Number
Floor Mounted Document Stand	27 lbs.	A900S
Wall Mounted Document Stand	25 lbs.	A900SW



DELUXE 13"x 26" DOCUMENT STAND

DOCUMENT STAND

Larger than the A900S (above, right) features two 26"W x 13"H panels. It is also available in a Deluxe version. All models have a writing surface with two clips and hinged, clear document protector. Standard model has three glides. Deluxe model includes three locking casters, lockable tray beneath writing panel, side tray, solar powered calculator, and clear hinged acrylic panels on display panel. Writing surface is 38" high. Overall height 61". Panels are yellow high impact polystyrene. Wall mounted unit also available.

Description	Ship Wgt.	Model Number
Standard Document Stand	28 lbs.	A1000S
Deluxe Document Stand	34 lbs	A1000D
Wall Mounted Document Stand	26 lbs.	A1000SW



STANDARD "C" SIZE DOCUMENT STAND

Even larger DOCUMENT STAND

Features 26"W x 20"H back display panels designed for "C" sized drawings. Writing panel is 26" x 13". Includes writing surface with two clips and hinged, clear document protector. Stand has three glides. Writing surface is 38" high. Overall height 61". Panels are yellow high impact polystyrene.

Description	Ship Wgt.	Model Number
Standard "C" Size Document Stand	30 lbs.	A1500S



DELUXE INFORMATION STAND

INFORMATION STAND

Features a 4" deep drop pocket with 3-ring binder mechanism that will hold up to 250 sheets. Binder pocket has hinged, clear plastic cover. 26"W x 13"H inclined writing surface includes two clips and hinged, clear document protector. Standard model includes steel pedestal with glides. Deluxe unit includes casters, lockable tray, and side tray. Writing surface is 38" high. Also available with "landscape" drop pocket panel, shown at right (panel is vertical so pages are displayed horizontally). Panels are yellow high impact polystyrene.

Description	Ship Wgt.	Model Number
Standard Information Stand	31 lbs.	A1200S
MSDS Right-to-Know Stand <i>click link to view separate flyer for more info</i>	31 lbs.	A1200-02
Deluxe Information Stand	45 lbs	A1200D
Landscape Information Stand	35 lbs.	A1210S



A1210S



MESSAGE BOARD

MESSAGE BOARD

Features 24"W x 18"H dry erase board above an inclined writing surface. Writing surface includes two clips and hinged, clear document protector. Heavy-duty steel stand has three glides. Writing surface is 38" high. Overall height 61". Panels are yellow high impact polystyrene.

Description	Ship Wgt.	Model Number
Message Board with Floor Stand	31 lbs.	A1600S

CATALOG DISPLAY STAND



CATALOG DISPLAY STAND

Makes an ideal reference center for product catalogs, specification sheets or repair manuals. Angled lower panel has twelve 1" three ring binder sections. Back 13" x 26" display panel includes two clips. Sturdy steel stand has dual columns and four feet with glides. Panels are yellow high-impact polystyrene.

Description	Ship Wgt.	Model Number
Catalog Display Stand	48 lbs.	A1700S

STANDARD DOCUMENT STAND with FLAT WRITING PANEL



DOCUMENT STAND with FLAT WRITING PANEL

Available in two sizes. Model A2000S has two 26"W x 13"H panels. Model A2500S features a 26"W x 20"H back panel for "C" size documents and 26" x 13" writing panel. Both models have a writing surface with two clips and hinged, clear document protector. There are two clips on the back panel. Stand has three glides. Writing surface is 38" high. Panels are yellow high impact polystyrene.

Description	Ship Wgt.	Model Number
Standard 13" x 26" Document Stand	28 lbs	A2000S
Standard 20" x 26" Document Stand	30 lbs.	A2500S

STANDARD BLUEPRINT DISPLAY STAND with WRITING SURFACE



BLUEPRINT DISPLAY STAND plus WRITING SURFACE

Features a 36"W x 26"H display panel with three clips for "D" size prints. Inclined writing surface includes two clips and hinged and clear document protector. Standard model has four glides on steel stand. Deluxe model includes four casters, lockable tray, side tray, solar powered calculator and clear acrylic cover hinged to back panel. Panels are yellow high impact polystyrene.

Description	Ship Wgt.	Model Number
Standard Blueprint Display Stand	76 lbs	A4500S
Deluxe Blueprint Display Stand	85 lbs.	A4500D

INSPECTION STAND

Includes a 20" x 26" cushioned work surface and 13" x 26" back display panel with two clips. Deluxe version includes four locking casters, lockable utility drawer, and clear hinged acrylic panels on display panel. Standard model has four glides. Both models have dual column stand. Panels are yellow high impact polystyrene.

Description	Ship Wgt.	Model Number
Standard Inspection Stand	32 lbs.	A2700S
Deluxe Inspection Stand	36 lbs.	A2700D
Deluxe version with Glides	35 lbs.	A2700DG

BLUEPRINT DISPLAY STAND



BLUEPRINT DISPLAY STAND

Features 36"W x 26"H panel with three clips for "D" size prints. Base has five legged steel stand with glides. Panel is yellow high impact polystyrene.

Description	Ship Wgt.	Model Number
Blueprint Display Stand	40 lbs.	A4000S

DELUXE LARGE DISPLAY INSPECTION STAND



DELUXE LARGE DISPLAY INSPECTION STAND

Features 36"W x 26"H display panel with nine clips and 20" x 26" cushioned flat work surface. Deluxe model (standard model is not available) includes four casters on dual column stand and lockable utility drawer. Panels are yellow high impact polystyrene.

Description	Ship Wgt.	Model Number
Large Display Inspection Stand	101 lbs.	A2750D

PARTS CADDY



PARTS CADDY

Features 36"L x 26"W x 1 3/4"D tray with cushioned liner. Heavy-duty stand with four locking casters. Tray is yellow high impact polystyrene.

Description	Ship Wgt.	Model Number
Mobile Parts Caddy	50 lbs.	A4600S

The configuration of these workstands are a registered trademark of Hubbell, Inc.

QUALTECH® WORKSTANDS

Kaizen Event Display Stand



Designed for Kaizen Planning Events, this "D" sized display will find multiple uses around the shop and office, wherever small group communication is necessary. It comes supplied with one laminated "D" size planning chart (for wipe-off markers) and five pre-printed paper charts. Yellow high impact polystyrene display panel is 36" W x 26" H can also hold flip charts or display boards. Heavy duty adjustable stand features four locking casters. Panel can be tilted from vertical to horizontal. Three clips hold charts securely in place and a handy tray keeps markers within reach.



Description	Ship Wgt.	Model Number
Kaizen Event "D" size Display Stand	53 lbs.	A4000KBOB
Laminated Kaizen Planning Chart-22" x 34"	2 lbs	B4048
22" x 34" Planning Sheets-5 pac	2 lbs.	BB4049



Workplace Solutions

A DIVISION OF GLEASON REEL CORP.

Gleason Reel Corp.

600 South Clark St.
Mayville, WI 53050

PH: 920-387-4120 | FAX: 920-387-4189

www.hubbell-gleason.com