

***NEW!***  
From Gleason Reel  
***Series SR***  
***Cable Carriers***

- Complete range of styles & sizes.
- Control and Protect cables/hoses on moving machines of all sizes.
- Unique series for use on robots or other rotating machines.

# Gleason SR Cable Carriers

Six series with wide variety of sizes and features...one for almost every application.  
Control and protect cords, cables or hoses powering moving equipment.



## Light Series

Includes six sizes. Some models feature cable/hose separators and removable nylon carrier bars. Molded nylon links easily snap together to customize length. Internal height range from 0.47" to 1.00" (12–25.5mm).

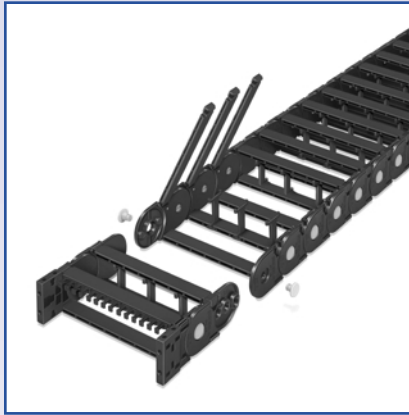

## Medium Series

Molded nylon links connected by single pivot pins. Some models feature removable carrier bars and movable separators. Internal height range from 0.67" to 2.36" (35–60mm).



## Heavy Series

First developed in late 1970s for heavy duty machine tool applications. Features proven male/female links with strong three pin pivot. Internal height range from 1.18" to 2.99" (30–112mm).



## Robotic Series

Patented "circular path" design. Rotation up to 540°. Speeds to 180°/second. Internal height range from 1.18" to 2.32" (30–59mm).

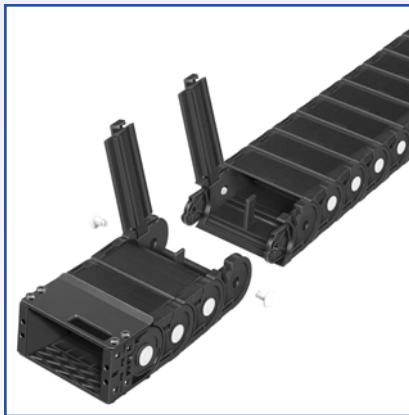

## Protection Series

Completely enclosed design for maximum cable protection. Snap open covers speed cable/hose installation. Internal height range from 1.42" to 2.83" (36–72mm).

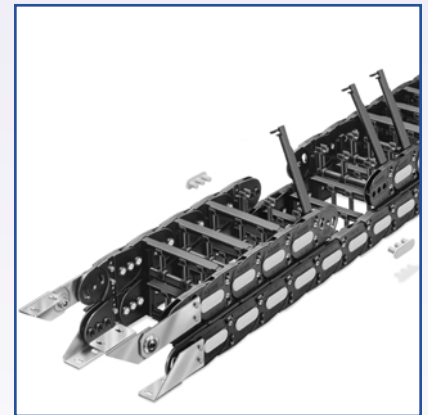

## Sliding Series

Ideal for extra-long travel distances. Used with guide trays. Internal height range from 1.18" to 2.76" (30–70mm).

For more information contact:



**Gleason Reel Corp.**  
600 South Clark St. • P.O. Box 26  
Mayville, WI 53050  
920-387-4120  
[www.gleasonreel.com](http://www.gleasonreel.com)