

Type "B" features Aluminum Rods and Adjustable Nylon Separators. Rods available in custom lengths so carrier width can be tailored to your requirements.



Type "T" features Extruded Aluminum Cross Pieces and Adjustable Nylon Separators. Extrusions available in custom lengths so width can be tailored to your requirements.

Heavy Series **Cable Carriers**

Types "B" and "T" for utmost versatility of application.
Strongest compact design nylon carrier in the industry.
Proven male/female links and exceptionally strong 3-pin pivot.

- Internal height range: 1.18-4.41 inches (30-112mm)
- Self-supporting maximum length: 22.97 ft. (7 m)

HEAVY SERIES

SR306B

Aluminum rods to support cables or hoses.
Standard carriers equipped with aluminum rods mounted on every second link. Also available with rods on every link.**

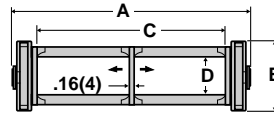

Carrier** part number	Radius R**** in (mm)	Curve Length M**** in (mm)	O.A. Height H**** in (mm)	Outside Width A in (mm)	Outside Height B in (mm)	Inside Width C in (mm)	Inside Height D in (mm)	Weight lb/ft(kg/m)	Nylon Bracket F in (mm)	Steel Bracket F in (mm)
SR306B075□*	2.95 (075)	14.57 (370)	8.07 (205)	4.53 (115)	2.17 (55)	2.95 (75)	1.18 (30)	1.08 (1.60)	3.78 (96)	2.80 (71)
SR306B100□*	4.21 (107)	18.50 (470)	10.59 (269)	5.51 (140)	2.17 (55)	3.94 (100)	1.18 (30)	1.11 (1.65)	4.76 (121)	3.78 (96)
SR306B150□*	5.91 (150)	23.82 (605)	13.98 (355)	7.48 (190)	2.17 (55)	5.91 (150)	1.18 (30)	1.21 (1.80)	6.73 (171)	5.75 (146)
SR306B200□*	7.87 (200)	29.92 (760)	17.91 (455)	9.45 (240)	2.17 (55)	7.87 (200)	1.18 (30)	1.28 (1.90)	8.70 (221)	7.72 (196)
SR306B250□*	9.84 (250)	36.22 (920)	21.85 (555)	11.42 (290)	2.17 (55)	9.84 (250)	1.18 (30)	1.34 (2.00)	10.67 (271)	9.69 (246)
SR306B300□*	11.81(300)	42.32(1075)	25.79 (655)	13.39 (340)	2.17 (55)	11.81(300)	1.18 (30)	1.44 (2.15)	12.64 (321)	11.65(296)
SR306B□□□□***				C+1.57(C+40)	2.17 (55)	...	1.18 (30)	...	A-0.75(A-19)	A-1.73(A-44)

* Complete model number by inserting radius (R) code: Example—SR306B075 **1**

Where: 1=075; 2=107; 3=150; 4=200; 5=250; 6=300

Standard carrier equipped with aluminum rods every second link. To order aluminum rods at every link, add letter **D at end of number: Example—SR306B075**1D**.

***Custom width carriers. Complete number by inserting value of C (mm) and radius (R) code:

Example—SR306B **2|5|5|1**

**** Refer to diagram on back page.

Technical characteristics when self-supported

Speed	26.25 ft/s	(8 m/s)
Acceleration	131.23 ft/s ²	(40 m/s ²)

Pitch 2.56 in. (65 mm)

Mounting Brackets

Complete set, assembled	Nylon p/n AN306KM
Complete set, unassembled	Nylon p/n AN306K

Separator
Unassembled p/n S2000F
Assembled p/n S2000FMC

Zinc Plated Steel^① p/n A306KM□^②
Zinc Plated Steel^① p/n A306K□^②

Pin
Part no.
PG307

Pin
Removal Tool
p/n PZ036

① Also available in stainless steel.

② Indicate mounting position variation. See drawings on back page.

Mounting Bracket Details.

Sold in sets of two.

Dimensions in inches (mm).

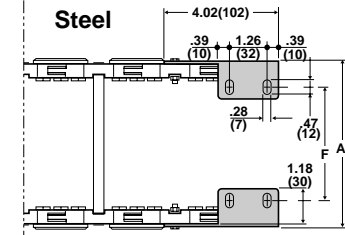
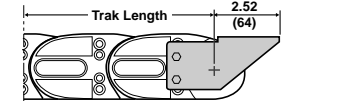
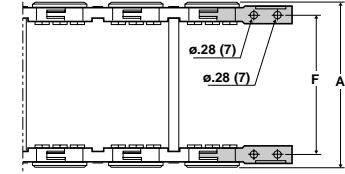
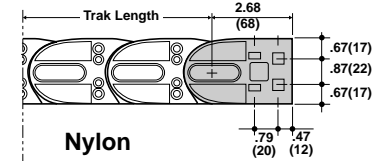

HEAVY SERIES

SR307B

Aluminum rods to support cables or hoses.
Standard carriers equipped with aluminum rods mounted on every second link. Also available with rods on every link.**

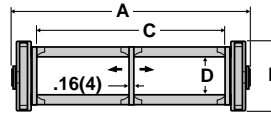

Carrier** part number	Radius R**** in (mm)	Curve Length M**** in (mm)	O.A. Height H**** in (mm)	Outside Width A in (mm)	Outside Height B in (mm)	Inside Width C in (mm)	Inside Height D in (mm)	Weight lb/ft(kg/m)	Nylon Bracket F in (mm)	Steel Bracket F in (mm)
SR307B075□*	2.95 (075)	14.76 (375)	8.43 (214)	4.61 (117)	2.52 (64)	2.95 (75)	1.57 (40)	1.21 (1.80)	3.86 (98)	2.68 (68)
SR307B100□*	3.54 (090)	16.73 (425)	9.61 (244)	5.59 (142)	2.52 (64)	3.94 (100)	1.57 (40)	1.24 (1.85)	4.84 (123)	3.66 (93)
SR307B150□*	4.72 (120)	20.47 (520)	11.97 (304)	7.56 (192)	2.52 (64)	5.91 (150)	1.57 (40)	1.31 (1.95)	6.81 (173)	5.63 (143)
SR307B200□*	5.51 (140)	22.83 (580)	13.54 (344)	9.53 (242)	2.52 (64)	7.87 (200)	1.57 (40)	1.38 (2.05)	8.78 (223)	7.60 (193)
SR307B250□*	7.87 (200)	30.31 (770)	18.27 (464)	11.50 (292)	2.52 (64)	9.84 (250)	1.57 (40)	1.44 (2.15)	10.75 (273)	9.57 (243)
SR307B300□*	9.84 (250)	36.42 (925)	22.20 (564)	13.46 (342)	2.52 (64)	11.81 (300)	1.57 (40)	1.51 (2.25)	12.72 (323)	11.54(293)
SR307B□□□□***				C+1.65(C+42)	2.52 (64)	...	1.57 (40)	...	A-0.75(A-19)	A-1.93(A-49)

* Complete model number by inserting radius (R) code: Example—SR307B075 **1**

Where: 0=090; 1=120; 2=140; 3=200; 4=250; 7=075

Standard carrier equipped with aluminum rod every second link. To order aluminum rod at every link, add letter **D at end of number: Example—SR307B075**1D**.

***Custom width carriers. Complete number by inserting value of C (mm) and radius (R) code:

Example—SR307B **2|5|5|1**

**** Refer to diagram on back page.

Technical characteristics when self-supported

Speed	26.25 ft/s	(8 m/s)
Acceleration	131.23 ft/s ²	(40 m/s ²)

Pitch 2.76 in. (70 mm)

Mounting Brackets

Complete set, assembled	Nylon p/n AN307KM
Complete set, unassembled	Nylon p/n AN307K

Separator
Unassembled p/n S307
Assembled p/n S307MC

Zinc Plated Steel^① p/n A307KM□^②
Zinc Plated Steel^① p/n A307K□^②

Pin
Part no.
PG307

Tool to remove connecting pins p/n PZ036

① Also available in stainless steel.

② Indicate mounting position variation. See drawings on back page.

Mounting Bracket Details.

Sold in sets of two.

Dimensions in inches (mm).

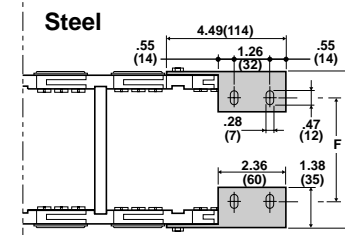
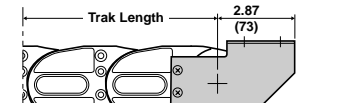
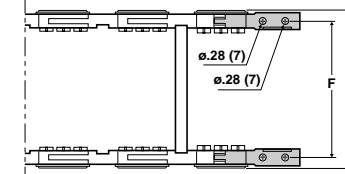
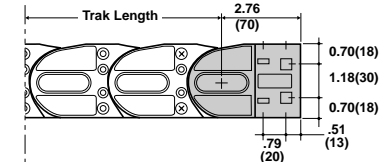

HEAVY SERIES

SR308B

Aluminum rods to support cables or hoses.
Standard carriers equipped with aluminum rods mounted on every second link. Also available with rods on every link.**

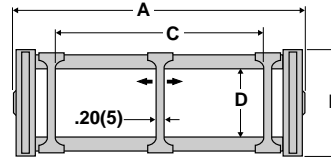

Mounting Bracket Details.

Sold in sets of two.
Dimensions in inches (mm).

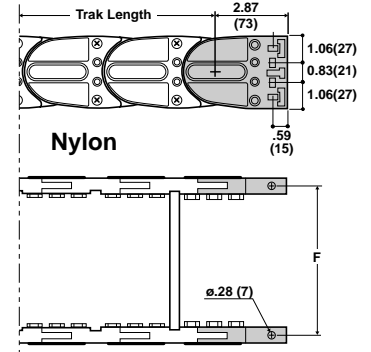

Carrier** part number	Radius R**** in (mm)	Curve Length A**** in (mm)	O.A. Height B**** in (mm)	Outside Width C in (mm)	Outside Height D in (mm)	Inside Width Weight in (mm)	Inside Height F in (mm)	Weight lb/ft(kg/m)	Nylon Bracket F in (mm)	Steel Bracket F in (mm)
SR308B100□*	5.91 (150)	25.00 (635)	14.76 (375)	6.14 (156)	2.95 (75)	3.94 (100)	1.89 (48)	1.92 (2.85)	5.31 (135)	3.66 (93)
SR308B150□*	7.09 (180)	28.54 (725)	17.13 (435)	8.11 (206)	2.95 (75)	5.91 (150)	1.89 (48)	2.02 (3.00)	7.28 (185)	5.63 (143)
SR308B200□*	7.87 (200)	31.10 (790)	18.70 (475)	10.07 (256)	2.95 (75)	7.87 (200)	1.89 (48)	2.12 (3.15)	9.25 (235)	7.60 (193)
SR308B250□*	9.06 (230)	34.84 (885)	21.06 (535)	12.04 (306)	2.95 (75)	9.84 (250)	1.89 (48)	2.22 (3.30)	11.22 (285)	9.57 (243)
SR308B300□*	11.0 (280)	40.94(1040)	25.00 (635)	14.01 (356)	2.95 (75)	11.81(300)	1.89 (48)	2.32 (3.45)	13.19 (335)	11.54(293)
SR308B□□□□***	15.75(400)	55.91(1420)	34.45 (875)	C+2.20(C+56)	2.95 (75)	...	1.89 (48)	...	A-0.83(A-21)	A-2.48(A-63)

* Complete model number by inserting radius (R) code: Example—SR308B150 [1]

Where: 1=150; 2=180; 3=200; 4=230; 5=280; 6=400

**Standard carrier equipped with aluminum rod every second link. To order aluminum rod at every link, add letter D at end of number: Example—SR308B1501D.

***Custom width carriers. Complete number by inserting value of C (mm) and radius (R) code:

Example—SR308B [2][5][5][1]

**** Refer to diagram on back page.

Technical characteristics when self-supported

Speed	26.25 ft/s	(8 m/s)
Acceleration	131.23 ft/s ²	(40 m/s ²)
Pitch	3.15 in.	(80 mm)

Separator	Pin
Unassembled p/n S3000F	p/n PG308
Assembled p/n S300FMC	

Mounting Brackets

Complete set, assembled	Nylon p/n AN308KM	Zinc Plated Steel① p/n A308KM□②	Pin Removal Tool p/n PZ038
Complete set, unassembled	Nylon p/n AN308K	Zinc Plated Steel① p/n A308K□②	

① Also available in stainless steel.

② Indicate mounting position variation. See drawings on back page.

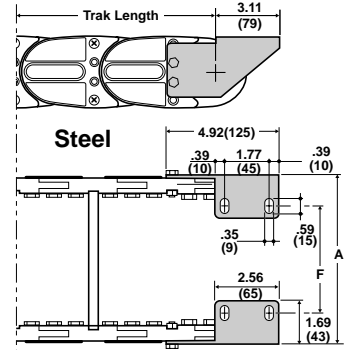

HEAVY SERIES

SR309B

Aluminum rods to support cables or hoses.
Standard carriers equipped with aluminum rods mounted on every second link. Also available with rods on every link.**

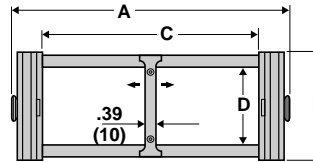

Mounting Bracket Details.

Sold in sets of two.
Dimensions in inches (mm).

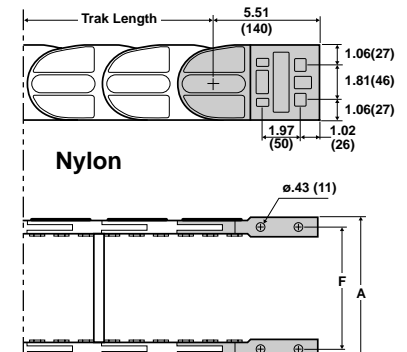

Carrier** part number	Radius R**** in (mm)	Curve Length M**** in (mm)	O.A. Height H**** in (mm)	Outside Width A in (mm)	Outside Height B in (mm)	Inside Width C in (mm)	Inside Height D in (mm)	Weight lb/ft(kg/m)	Nylon Bracket F in (mm)	Steel Bracket F in (mm)
SR309B100□*	7.87 (200)	32.68 (830)	19.69 (500)	6.14 (156)	3.94 (100)	3.94 (100)	2.76 (70)	2.82 (4.20)	5.08 (129)	3.43 (87)
SR309B150□*	8.11 (206)	38.78 (985)	23.62 (600)	8.11 (206)	3.94 (100)	5.91 (150)	2.76 (70)	2.96 (4.40)	7.05 (179)	5.39 (137)
SR309B200□*	9.84 (250)	45.08(1145)	27.56 (700)	10.08 (256)	3.94 (100)	7.87 (200)	2.76 (70)	3.06 (4.55)	9.02 (229)	7.36 (187)
SR309B250□*	11.81(300)	51.18(1300)	31.50 (800)	12.05 (306)	3.94 (100)	9.84 (250)	2.76 (70)	3.16 (4.70)	10.98 (279)	9.33 (237)
SR309B300□*	13.78(350)	57.48(1460)	35.43 (900)	14.02 (356)	3.94 (100)	11.81 (300)	2.76 (70)	3.26 (4.85)	12.95 (329)	11.30(287)
SR309B400□*	15.75(400)	69.69(1770)	43.31(1100)	17.95 (456)	3.94 (100)	15.75 (400)	2.76 (70)	3.49 (5.20)	16.89 (429)	15.24(387)
SR309B□□□□***	19.69(500)	69.69(1770)	43.31(1100)	C+2.20(C+56)	3.94 (100)	...	2.76 (70)	...	A-1.06(A-27)	A-2.72(A-69)

* Complete model number by inserting radius (R) code: Example—SR309B150 [3]

Where: 2=200; 3=250; 4=300; 5=350; 6=400; 7=500

**Standard carrier equipped with aluminum rod every second link. To order aluminum rod at every link, add letter D at end of number: Example—SR309B1503D.

***Custom width carriers. Complete number by inserting value of C (mm) and radius (R) code:

Example—SR309B [2][5][5][3]

**** Refer to diagram on back page.

Technical characteristics when self-supported

Speed	26.25 ft/s	(8 m/s)
Acceleration	131.23 ft/s ²	(40 m/s ²)
Pitch	3.94 in.	(100 mm)

Separator	Pin
Unassembled p/n S309C	p/n PG309
Assembled p/n S309MC	

Mounting Brackets

Complete set, assembled	Nylon p/n AN309KM	Zinc Plated Steel① p/n A309KM□②	
Complete set, unassembled	Nylon p/n AN309K	Zinc Plated Steel① p/n A309K□②	

① Also available in stainless steel.

② Indicate mounting position variation. See drawings on back page.

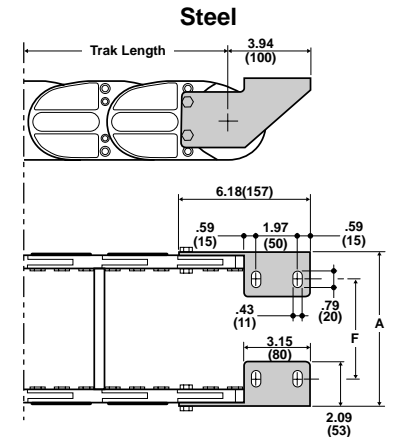

HEAVY SERIES

SR310T

Largest carrier in the Heavy Series.
 Extruded aluminum cross pieces.
 Standard carriers equipped with aluminum cross pieces mounted on every link. Movable separators can be installed to create different compartments.

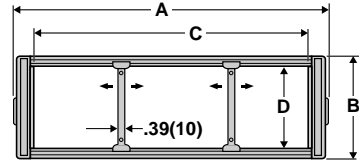

Mounting bracket details.
 Sold in sets of two.
 Dimensions in inches (mm).

Steel only

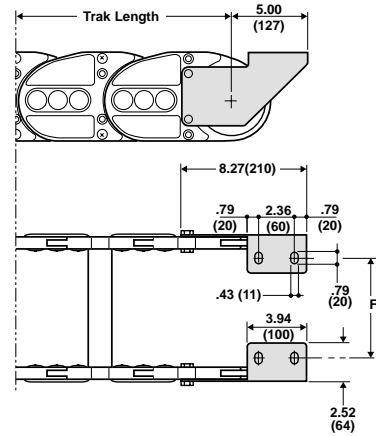

Carrier** part number	Radius R*** in (mm)	Curve Length M*** in (mm)	O.A. Height H*** in (mm)	Outside Width A in (mm)	Outside Height B in (mm)	Inside Width C in (mm)	Inside Height D in (mm)	Weight lb/ft(kg/m)	Steel Bracket F in (mm)
SR310T200□□□*	7.87 (200)	36.22 (920)	21.64 (550)	10.24 (260)	5.91 (150)	7.87 (200)	4.41 (112)	4.80 (7.15)	7.09 (180)
SR310T300□□□*	11.81 (300)	48.62 (1235)	29.53 (750)	14.17 (360)	5.91 (150)	11.81 (300)	4.41 (112)	5.11 (7.60)	11.02 (280)
SR310T400□□□*	15.75 (400)	61.02 (1550)	37.40 (950)	18.11 (460)	5.91 (150)	15.75 (400)	4.41 (112)	5.41 (8.05)	14.96 (380)
SR310T500□□□*	19.69 (500)	73.23 (1860)	45.28(1150)	22.05 (560)	5.91 (150)	19.69 (500)	4.41 (112)	5.71 (8.50)	18.90 (480)
SR310T600□□□*	23.62 (600)	85.63 (2175)	53.15(1350)	25.98 (660)	5.91 (150)	23.62 (600)	4.41 (112)	6.05 (9.00)	22.83 (580)
SR310T□□□□□□**	29.53 (750)	104.33(2650)	64.96(1650)	C+2.36(C+60)	5.91 (150)	...	4.41 (112)	...	A-3.15(A-80)

* Complete model number by inserting radius (R) code: Example-SR310T300 **1 8 0**
 **Custom width carriers. Complete number by inserting value of C (mm) and radius (R) code:
 Example-SR310T **2 5 0 2 0 0**

*** Refer to diagram below.

Technical characteristics when self-supported

Speed	13.12 ft/s	(4 m/s)
Acceleration	65.62 ft/s ²	(20 m/s ²)
Pitch	5.71 in.	(145 mm)

Separator	Pin	Bushing
Unassembled p/n S310TC	Part no. PG310	Part no. B310
Assembled p/n S310TMC		

Mounting Brackets

Complete set, assembled	Zinc Plated Steel ^① p/n A310KM□ ^②
Complete set, unassembled	Zinc Plated Steel ^③ p/n A310K□ ^②

- ① Also available in stainless steel.
- ② Indicate mounting position variation. See drawings on back page.

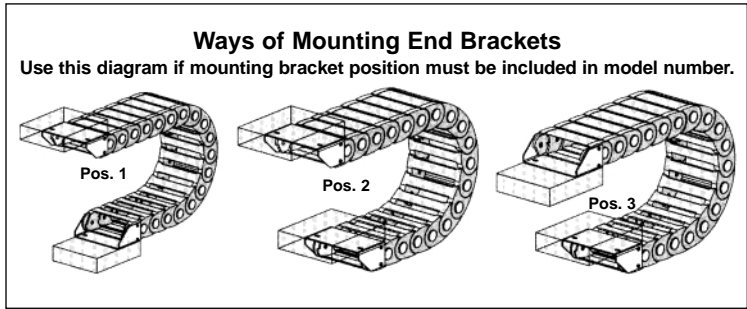
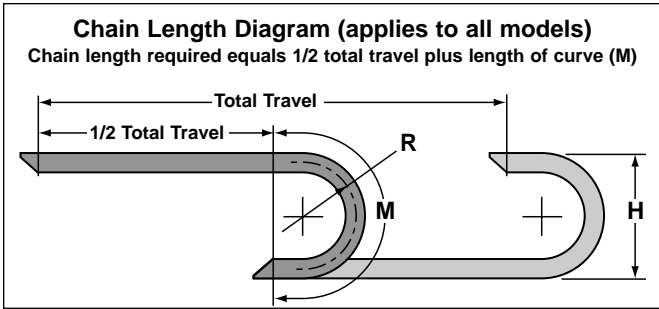

Ask your Gleason Representative about the full cable carrier line.

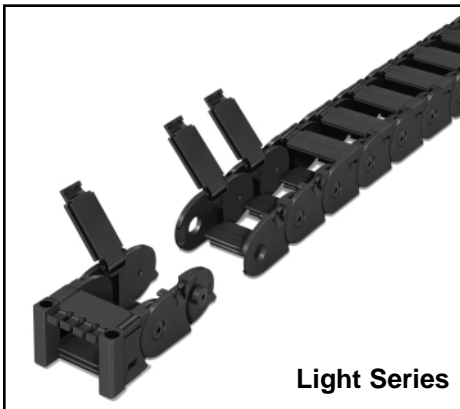

Gleason Reel Corp.
 600 South Clark Street
 P.O. Box 26
 Mayville, WI 53050
 Phone: 920-387-4120 Fax: 920-387-4189
 www.hubbell-gleason.com