

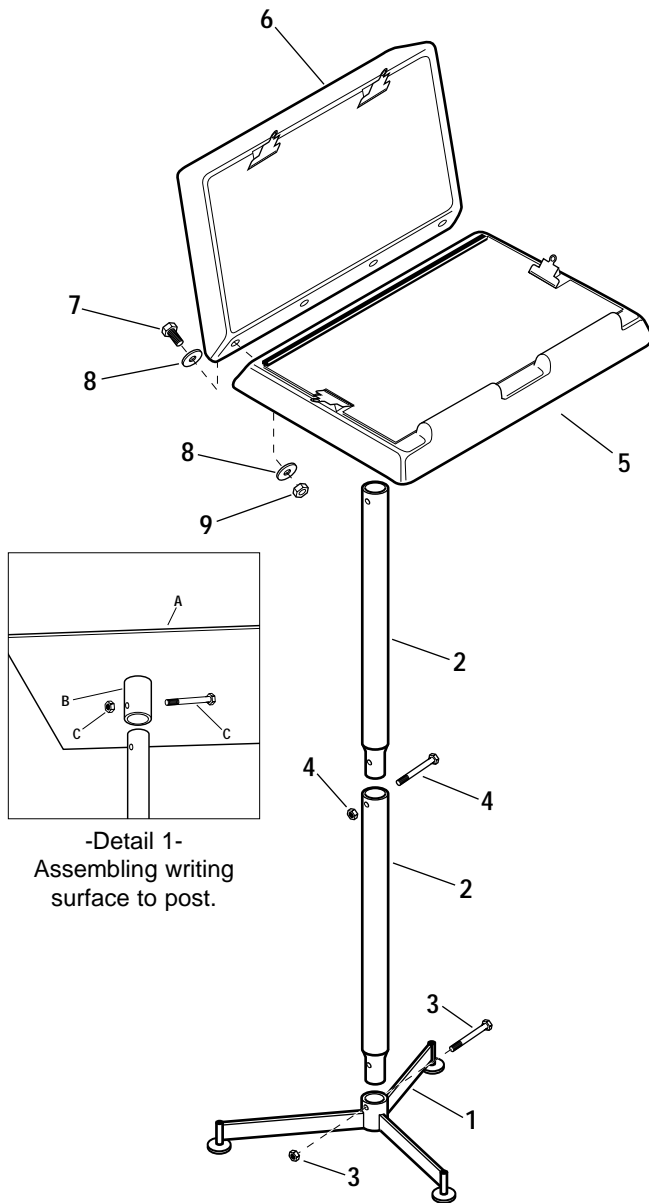

## Assembly Instructions 2000S, & 2500S Document Stand 2600S Inspection Stand



**NOTE:** This stand may be assembled with writing surface (item 5) at a height suitable for either standing use or seated use. To assemble for seated use, substitute 11" long post section for 22 1/2" long section (item 2).

Refer to illustration at left. *NOTE: The unit you are assembling may look slightly different than the illustration.*

1. Identify posts for stand (item 2).
2. Slide end of lower post (2) into base (1). Secure with screw and nut (3). Tighten. Slide upper post into top of lower post. Secure with screw and nut (4). Tighten.
3. Snap glides into base.
4. Slide sleeve on panel/tray assembly onto top of stand post (detail 1). Secure with screw and nut (C on Detail 1). Tighten.  
**NOTE:** Lower panel on model 2600S Inspection Stand has a writing surface plus a recessed parts tray but assembly procedure is the same as 2000S and 2500S.
5. Assemble display panel (6) to writing panel (5) using four bolts, flat washers and hex nuts (7, 8, 9). Tighten securely.
6. Remove protective sheets from clear acrylic covers by running knife blade along edge of hinge and stripping off tinted plastic..
7. Model 2600S only: Install neoprene liner in parts tray.



**Workplace Solutions**

P.O. Box 26 • 600 South Clark St.  
Mayville, WI 53050  
Phone: 920-387-4120  
Fax: 920-387-4189