

ASSEMBLY INSTRUCTIONS

PUSH 'n PLACE MOBILE WORKSTATION

DESCRIPTION

The **PUSH 'n PLACE Mobile Workstation** allows user to roll a fully equipped workstation to the work sight, connect an air line and perform the required tasks. Optional glide feet rather than casters may be used in semi-permanent applications. The 60" tool rail is equipped with a labyrinth tool trolley with brass air fitting. **Maximum rated capacity 50 lbs.** Also included is an air manifold which is connected to the brass fitting on the trolley via a 3/8" ID x 48" air line, a shelf and a rack for hanging plastic bins, the ideal place for hardware as well as tools. Bin boxes are not included. Tool balancer, coiled air line and air tool are optional extras.

NOTE:

Prior to assembly, become familiar with the following instructions and names of components as shown below.

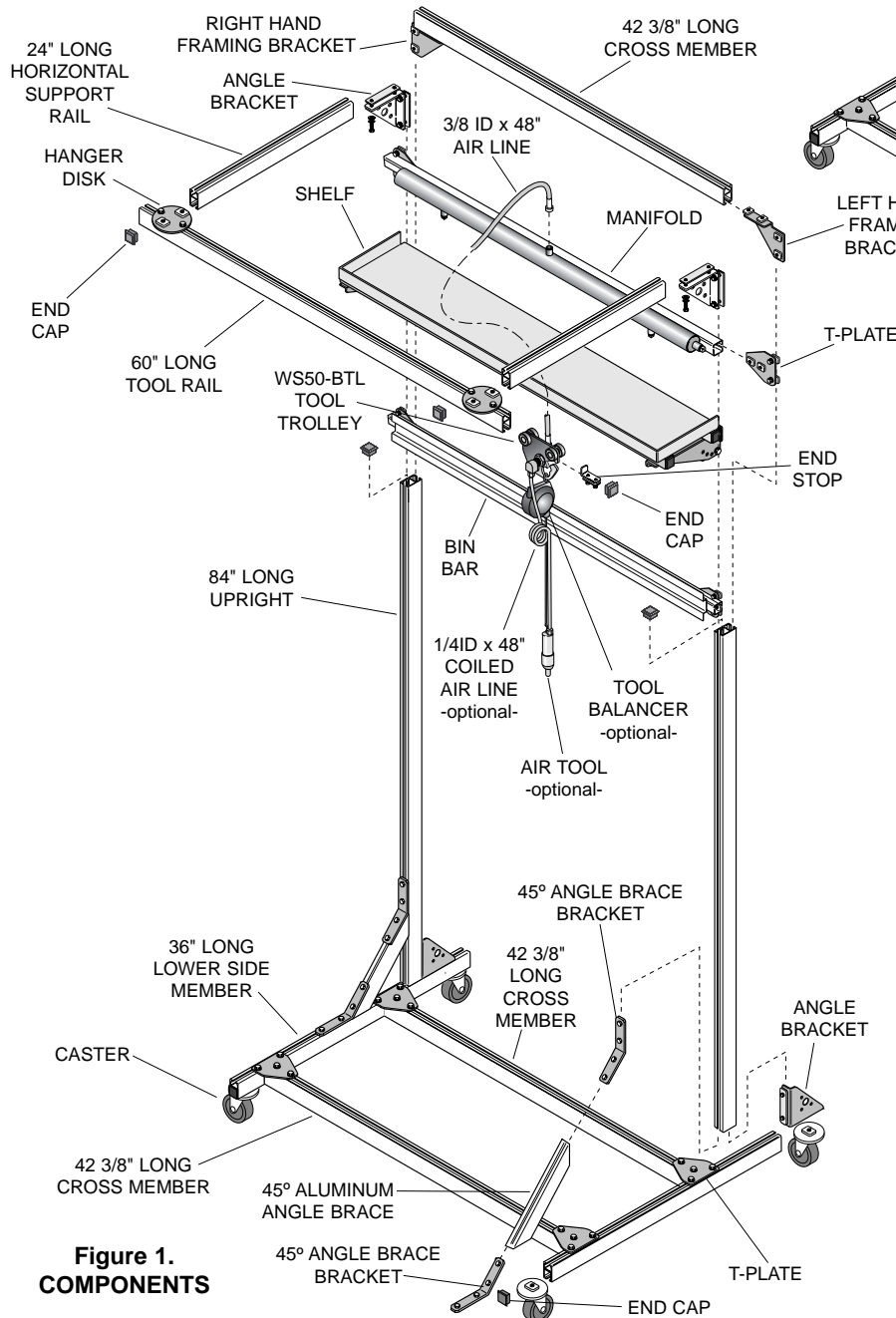
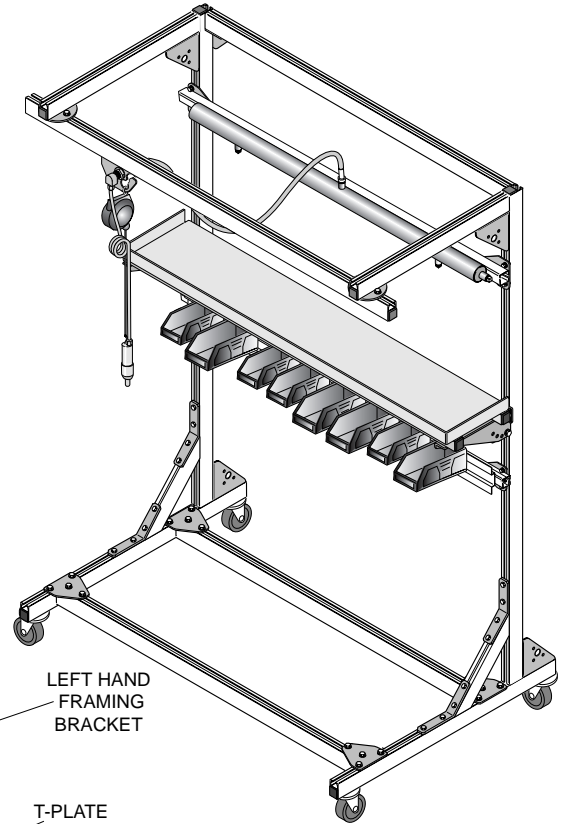
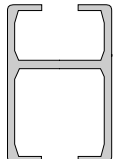

Figure 1.
COMPONENTS



IMPORTANT ASSEMBLY NOTES

- Components are assembled using the Hubbell Workplace Solutions "ALIGN – SET – TIGHTEN" system. Brackets are clamped to aluminum extrusions with track nuts in one of the two inside cavities. Always install track nuts with widest dimension perpendicular to aluminum rail.
- All main frame members are extruded aluminum rail. Install with large cavity down. 
- All brackets, manifold, shelf and bin bar are steel and are shipped with assembly hardware (usually track nuts) installed. Some track nuts may have to be reversed (bolt head on opposite side of plate) for proper assembly. In addition, manifold, shelf and bin bar are also shipped with **E-Z Nuts** which may be inserted from the front of the upright rather than from the top. See separate instructions.

ASSEMBLY

1. Lay out all components. Locate bin bar, shelf, manifold, two 42 3/8" long aluminum cross members, two 24" long horizontal support rails, one 60" long tool rail, two hanger disks, one tool trolley, two end stops, one air line, four casters, and plastic end caps (Fig. 1). Set aside.

2. Locate two 36" long lower side members, two angle brackets and two T-plates. Place aluminum side members on floor with large slot down. Affix angle brackets and T-plates to side members by sliding track nuts into aluminum rails. Position as shown in Figure 2, and tighten track nuts to secure.

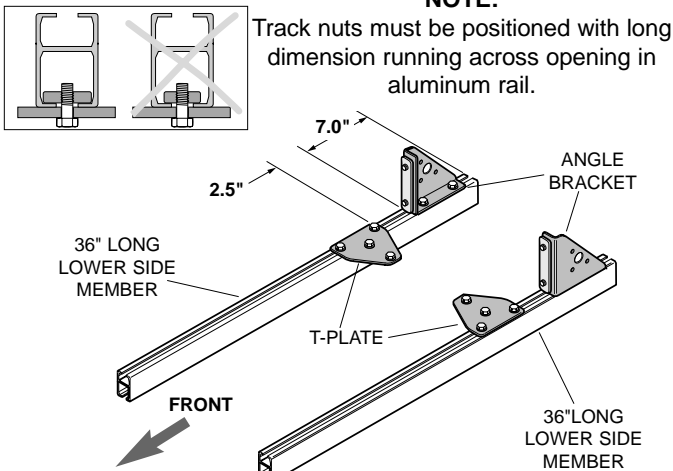

Figure 2.
ASSEMBLING LOWER SIDE MEMBERS

3. Locate two 84" long uprights, right hand framing bracket and left hand framing bracket. Affix framing brackets to uprights 2.6" from end of aluminum rail (Fig. 3). Wrench tighten to secure.

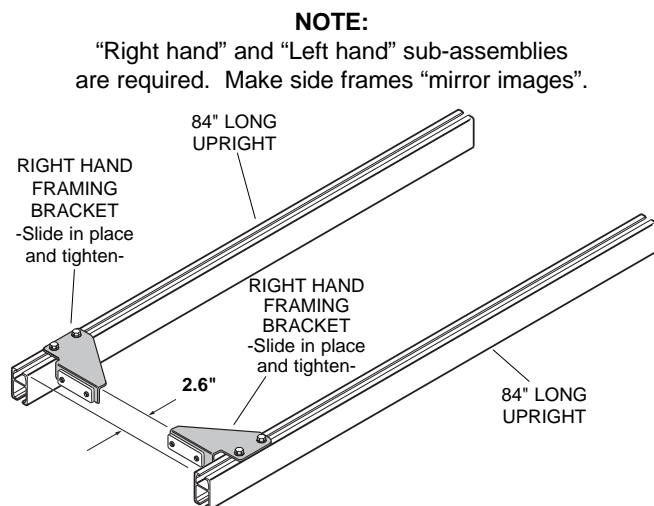

Figure 3.
ASSEMBLING FRAME UPRIGHTS

4. Locate two 45° aluminum angle braces and four 45° angle brace brackets. Assemble angle brace brackets to 45° aluminum angle braces. Orient angle brace brackets as shown and slide into position on lower frame members (Fig. 4). Finger tighten angle brace brackets at this time. Secure second set of T-plates to lower side members.

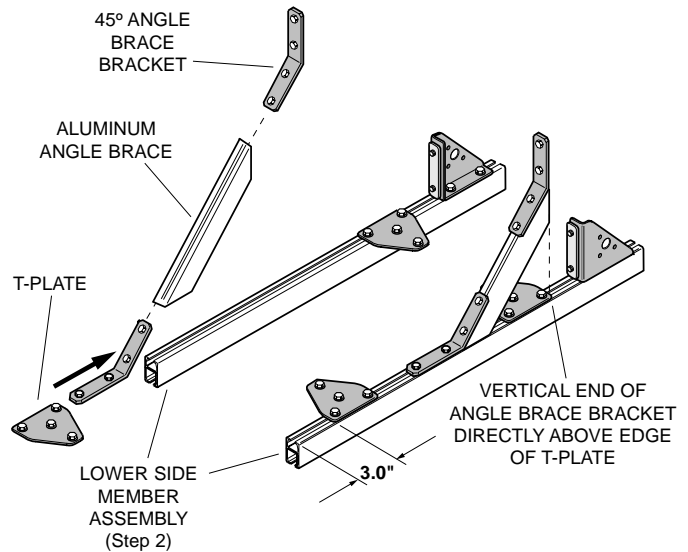

Figure 4.
ASSEMBLING ANGLE BRACES

5. Assemble one upright to corresponding lower side frame assembly by sliding onto angle brace bracket and triangular angle bracket. Wrench tighten locking plate bolts on angle bracket. Position aluminum angle brace so that ends are tight against lower side member and upright. Check to make sure upright is square with lower side member and wrench tighten all bolts (Fig. 5). Repeat for other side frame.

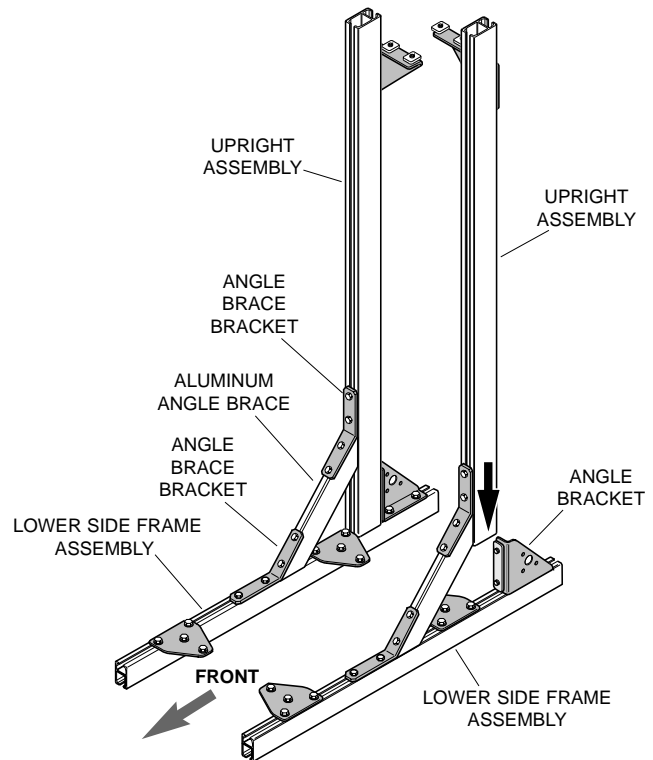

Figure 5.
ASSEMBLING UPRIGHTS TO LOWER SIDE MEMBERS

- Lay one side frame assembly (Step 5) flat. Slide two 42 3/8" long cross members into T-Plates at bottom and third 42 3/8" cross member into Framing Bracket at top. Slide cross members tight against side frame members and securely tighten track nut bolts (Fig 6).

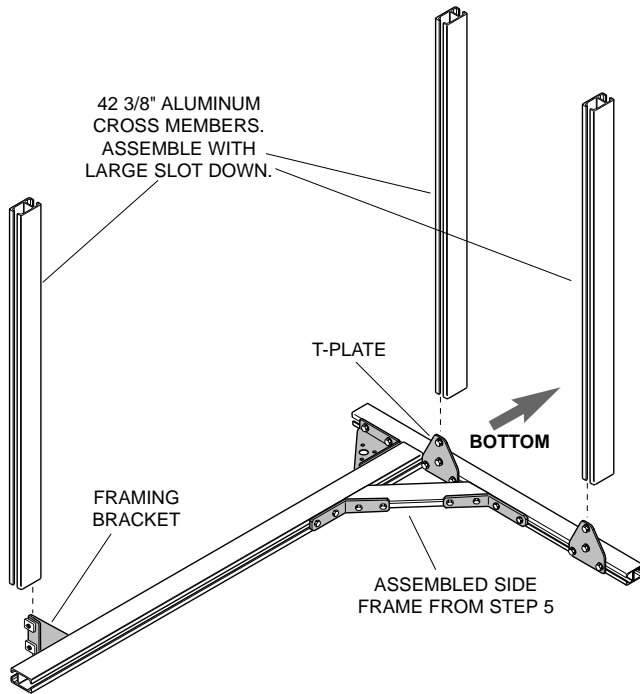

Figure 6.
INSTALLING CROSS MEMBERS

- Stand assembly upright and attach other side frame (Fig 7). Square unit and securely tighten all bolts.

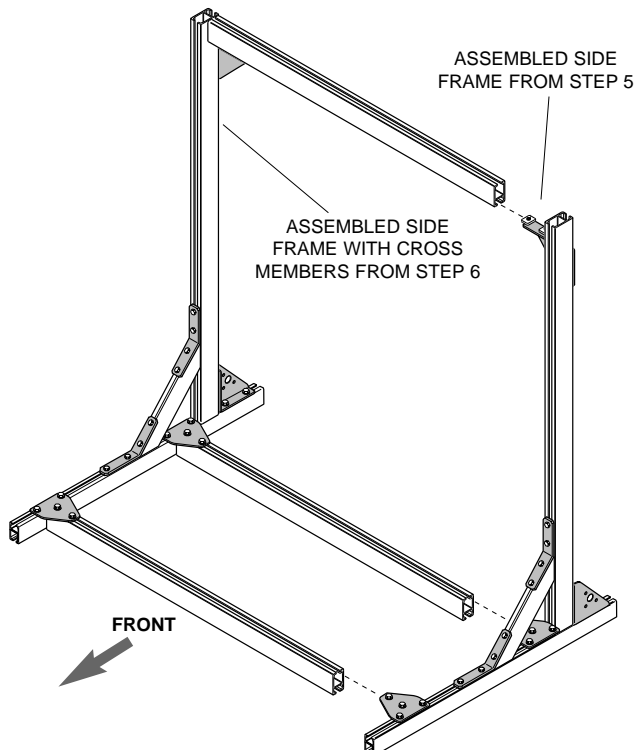

Figure 7.
COMPLETING FRAME ASSEMBLY

- Lay unit on its side and install casters or optional glide feet (Fig 8). Stand unit upright.

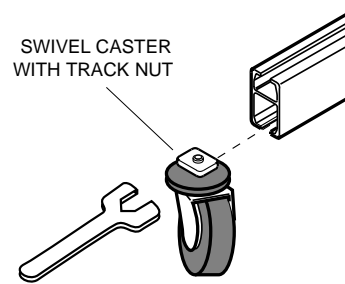

Figure 8A.
INSTALLING SWIVEL CASTERS

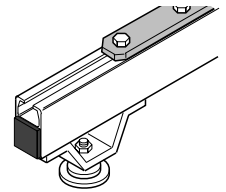

Figure 8B.
INSTALLING OPTIONAL GLIDE FEET
Glide feet attached to "U" shaped bracket which has two track nuts. Adjust feet to level unit.

IMPORTANT NOTE:

Pre-assembly planning is important.
Accessories load from the top of the frame uprights. Options such as Power Strip and Swing Arm mounting brackets must be installed **in order** and at the same time as the Bin Bar, Shelf and Manifold (Steps 9–11).

- Loosen unused track nuts on Bin Bar T-plates and slide unit onto top/front of uprights. Position Bin Bar at desired height and securely tighten all bolts. (Refer to Figure 1.) Loosen track nuts holding T-plates to Bin Bar or Manifold if required to achieve proper fit. Retighten.
- Loosen track nuts on Shelf mounting brackets and slide unit onto uprights in same manner as Bin Bar. Adjust shelf tilt and securely tighten all bolts. (Refer to Figure 1.)
- Loosen unused track nuts on Air Manifold T-plates and slide unit onto uprights in same manner as Bin Bar. Position Manifold with top of T-plates a minimum of 8.5" down from top of upright and securely tighten all bolts. (Refer to Figure 1.) Height of Bin Bar, Shelf, Manifold, or other accessories may be modified after assembly is completed.
- Slide Angle Brackets onto front side of uprights. Slide 24" long horizontal support rails onto top of angle brackets. Adjust so that tops of support rails are flush with top ends of uprights and so that support rail end butts firmly against upright. Tighten bolts to hold securely in place. (Refer to Figure 1).

- Slide Hanger Disks into top (small cavity) of 60" long Tool Rail. Space to width of frame and finger tighten. Slide hanger disks into front end of horizontal supports. Position tool rail where required but with hanger disks a minimum of 1.0" from support ends (Figs 1 & 9). Wrench tighten all track nuts.

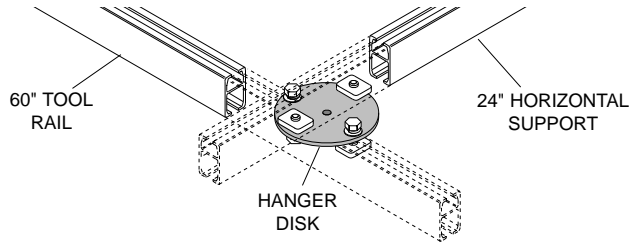

Figure 9.
HANGING TOOL RAIL

- Slide End Stop minimum of 2" into one end of trolley and tighten bolts to secure. Roll tool trolley into opposite end of tool rail. Install remaining End Stop (Fig. 10).

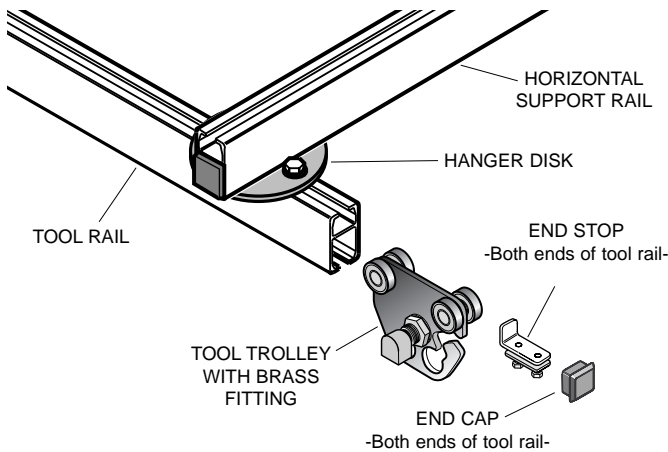

Figure 10.
INSTALLING TOOL TROLLEY AND END STOP

- Install 3/8" ID Air Line from Manifold to fitting on tool trolley (Fig. 11.)
- Install optional tool balancer, coiled air line and air tool.
- Complete assembly by installing end caps (Fig. 1).
- Check to make sure all bolts are tight and that unit is square (all four casters or feet firmly on floor).

USING PUSH 'n PLACE MOBILE WORKSTATION

- Roll unit to work area. Position legs beneath work bench or conveyor and lock casters.
- Attach feed air line to fitting at end of manifold.

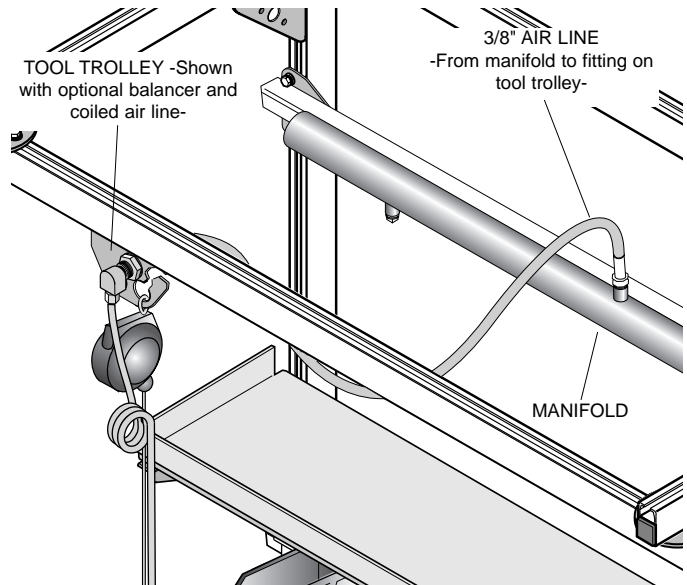

Figure 11.
INSTALLING AIR LINE

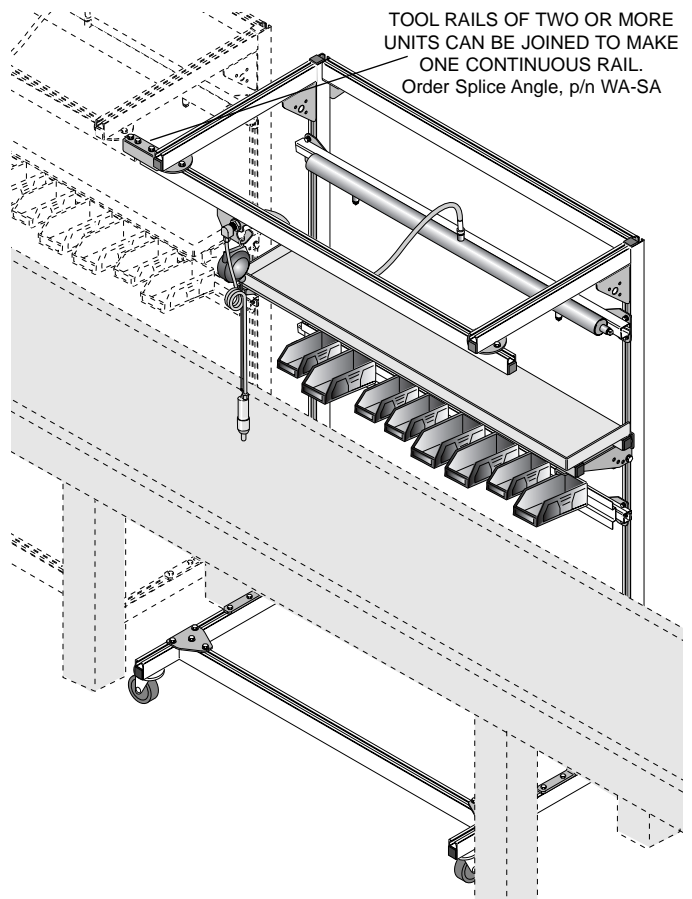

Figure 12.
TYPICAL INSTALLATION WITH CONVEYOR
Optional Splice Angle joining two units.



Workplace Solutions

P.O. Box 26 • 600 South Clark St.
Mayville, WI 53050
Phone 920-387-5195