

ASSEMBLY INSTRUCTIONS

BIN CART

DESCRIPTION

The **Bin Cart** is a rugged mobile unit designed to hold hanging bin boxes (not included). It may be rolled where needed in the work area. There are three bin support bars on each side, six total. All may be adjusted for optimum height. **Maximum rated capacity is 300 lbs.** Cart measures 36" wide x 77" high x 36" deep and is equipped with four locking, swivel casters.

NOTE: Prior to assembly, become familiar with the following instructions and names of components as shown below.

Figure 1.
COMPONENTS

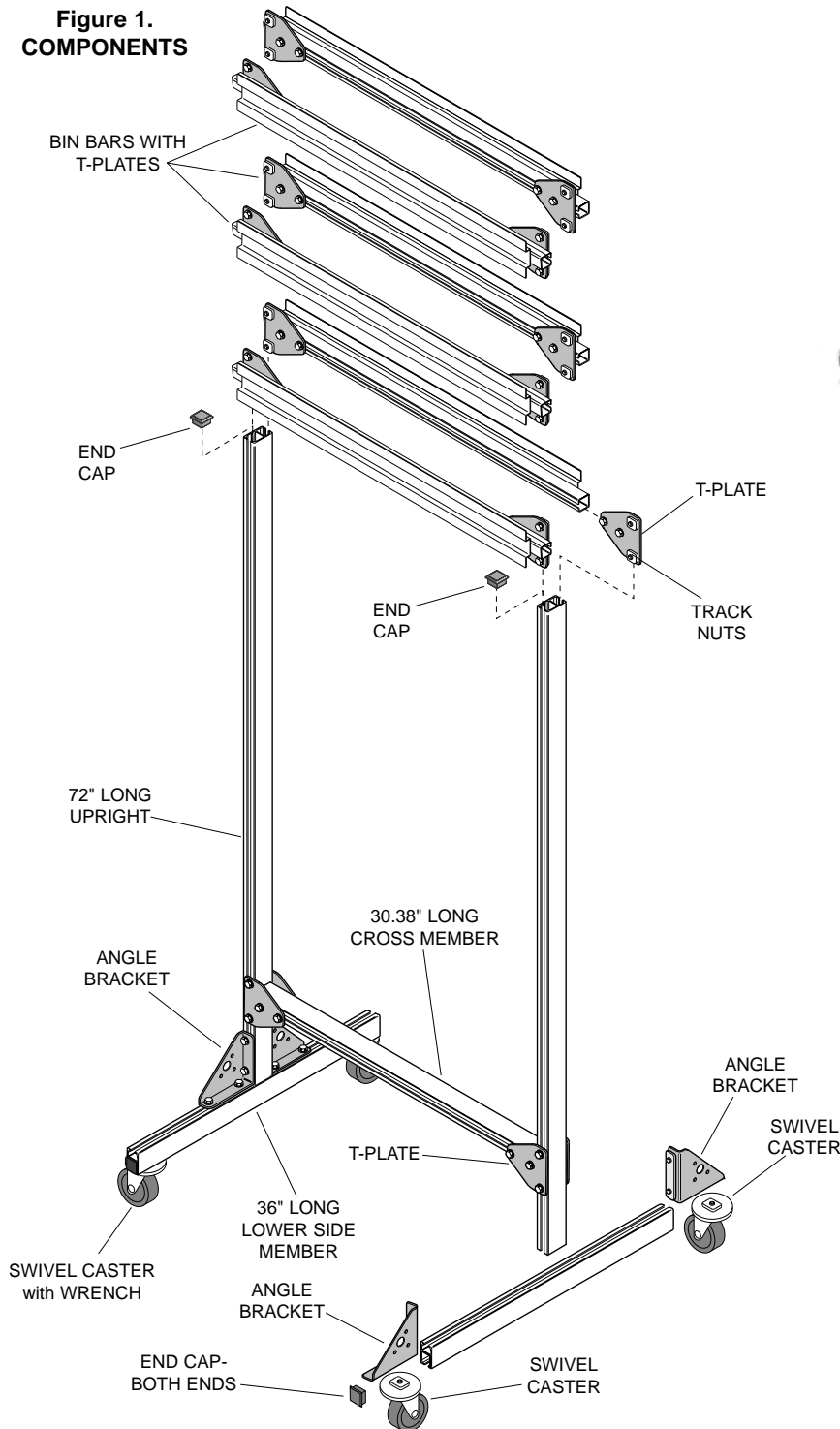

IMPORTANT ASSEMBLY NOTES

1. Components are assembled using the "ALIGN - SET - TIGHTEN" system; i.e. brackets are clamped to aluminum extrusions with track nuts inside one of the two cavities. Always install single bolt track nuts with widest dimension perpendicular to aluminum rail.

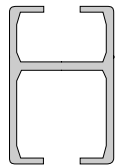

2. All main frame members are extruded aluminum rail. Unless installed flat (cross member), install horizontal members with large cavity down.
3. Bin bars and all brackets are steel and shipped with assembly hardware (usually track nuts) installed. Some track nuts may have to be reversed (bolt head on opposite side of plate) for proper assembly.

ASSEMBLY

1. Lay out all components. Locate bin bars, casters, and plastic end caps (Fig. 1) and set aside.
2. Locate two angle brackets and two T-plates. Place two 36" aluminum frame members on floor with large slot down. Affix angle brackets to side members by sliding track nuts into aluminum rails. Position as shown in Figure 2, and finger tighten track nuts.

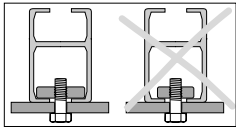

NOTE:
Position short (single bolt) track nuts with long dimension running across opening in aluminum rail.

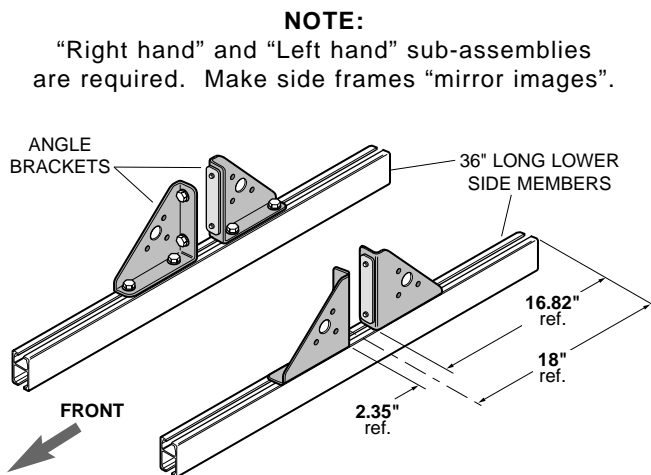

Figure 2.
ASSEMBLING LOWER SIDE MEMBERS

3. Locate two 72" long uprights. Assemble one upright to corresponding lower side frame assembly by sliding onto angle brackets. Be sure upright is centered on lower side member. Tighten all track nuts. Repeat for other side (Fig. 3).
4. Slide a T-plate into each side of uprights (Fig. 4). Allow T-plate to rest on angle bracket. Do not tighten until cross member is installed.

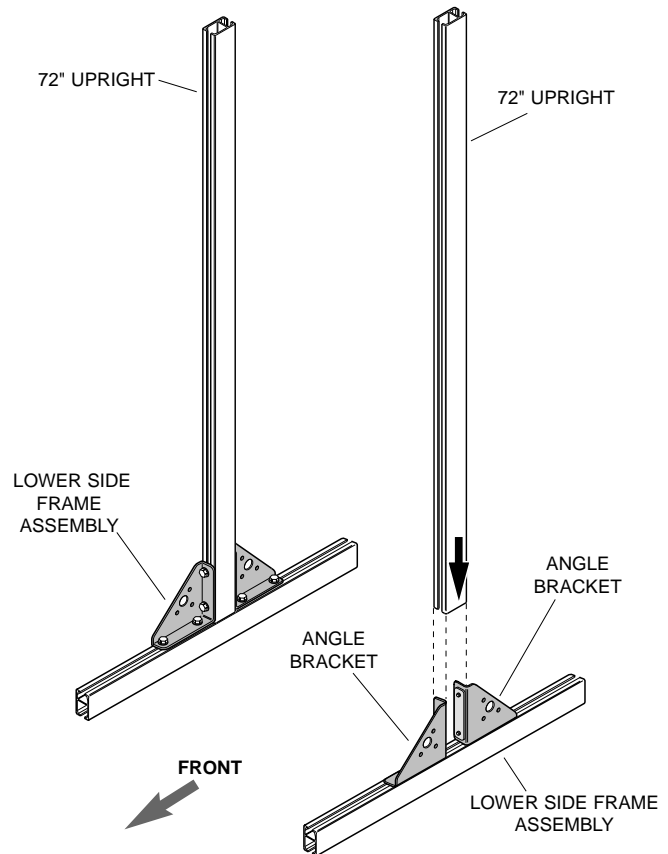

Figure 3.
ASSEMBLING UPRIGHTS TO LOWER SIDE MEMBERS

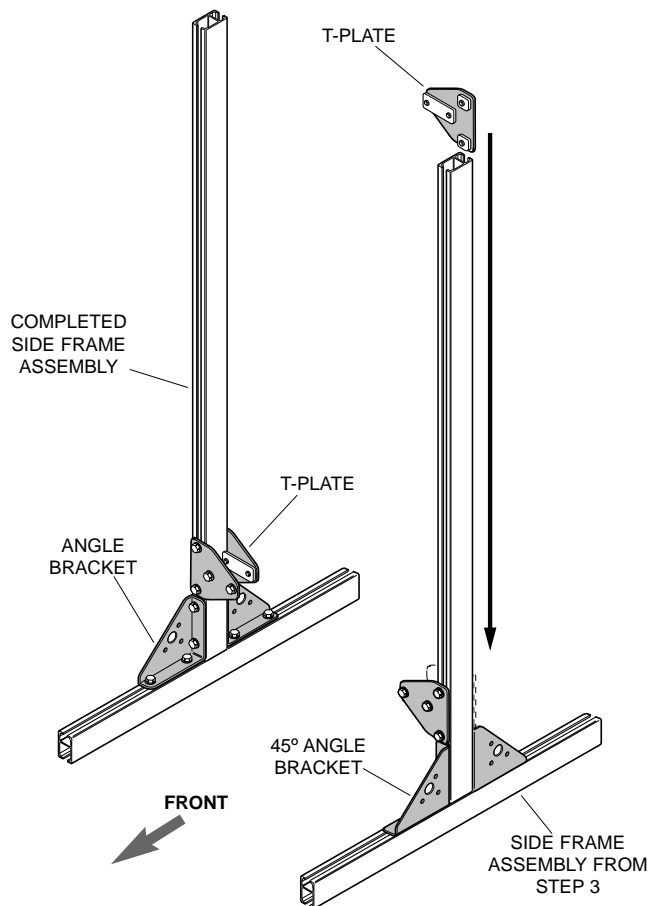

Figure 4.
INSTALLING T-PLATES

- Lay one side frame flat and slide cross member into T-plates. Slide cross member tight against side frame member and securely tighten track nut bolts (Fig 5).

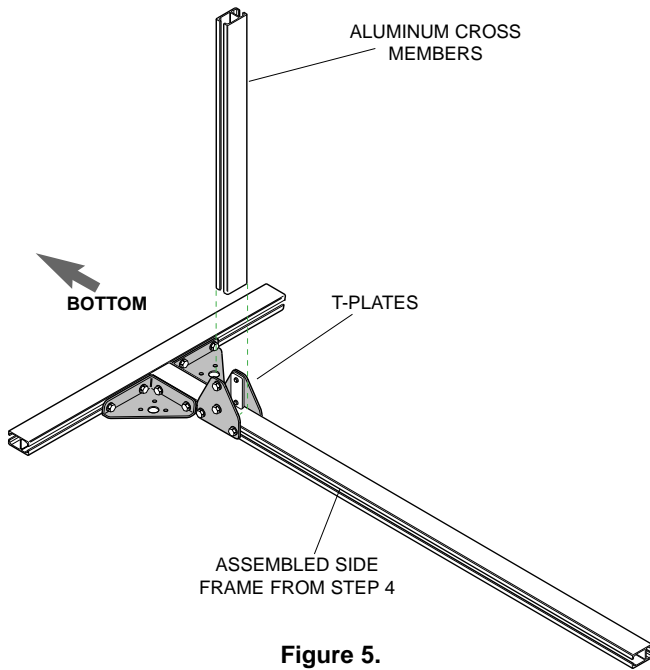

Figure 5.
INSTALLING CROSS MEMBER

- Stand assembly upright and attach other side frame (Fig 6). Square unit and securely tighten all bolts.

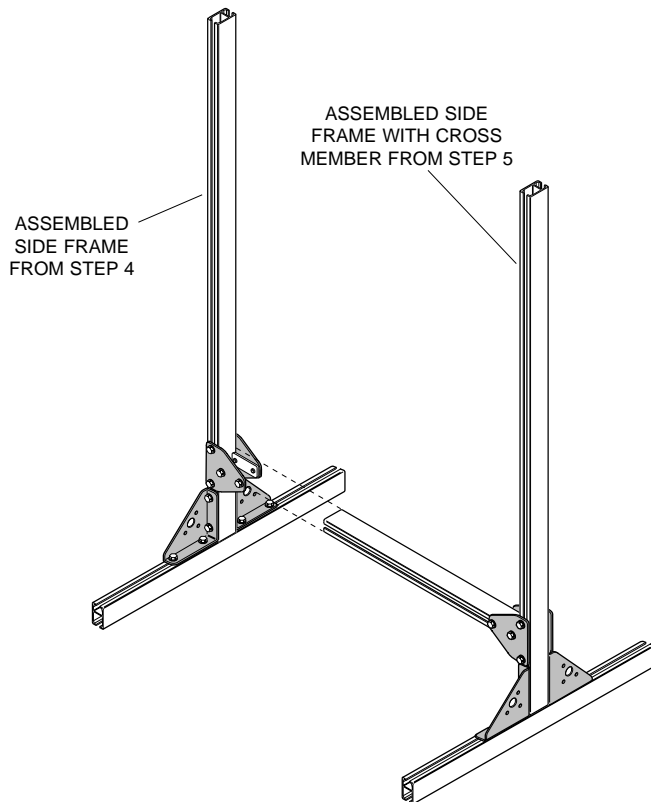

Figure 6.
COMPLETING FRAME

- Mount three bin bars to each side of frame uprights by sliding down from top with track nuts inside extrusion (Fig 7). Position as desired. Tighten securely.

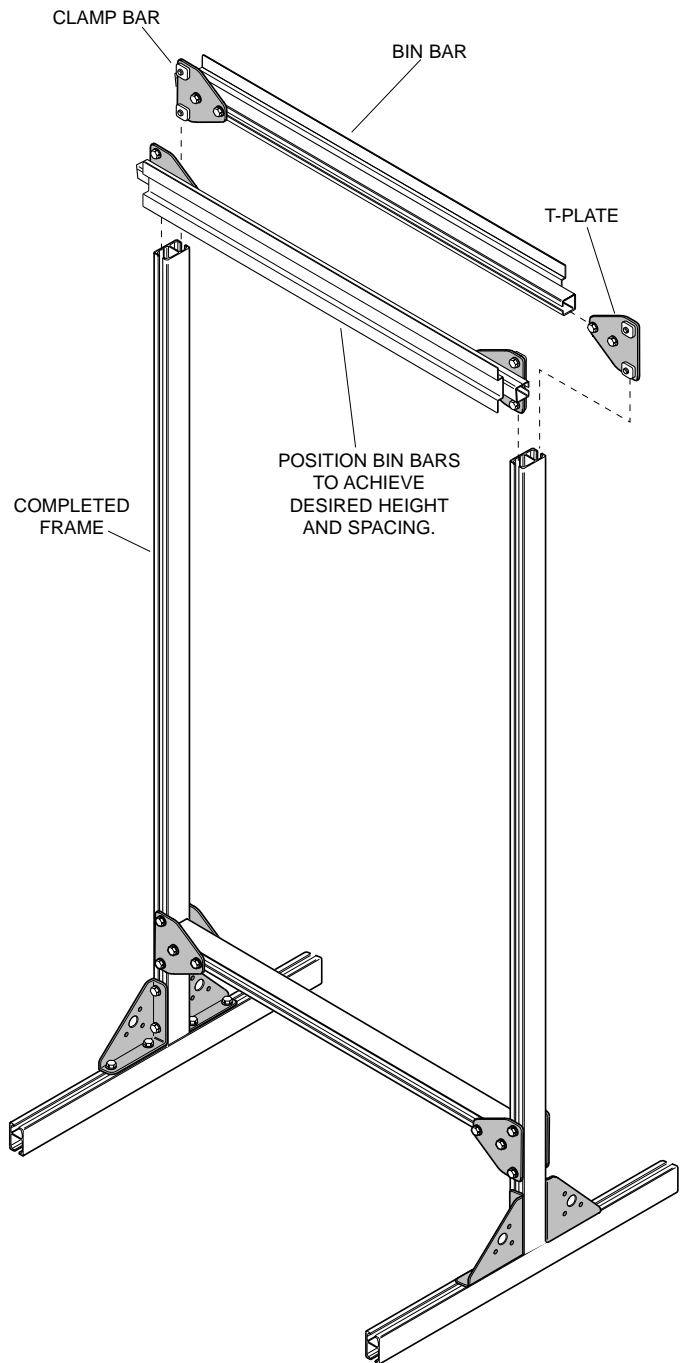
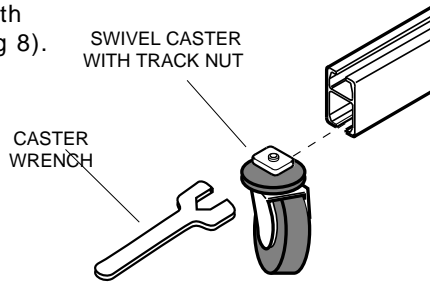

Figure 7.
ATTACHING BIN BARS

8. Install casters with wrench included (Fig 8).

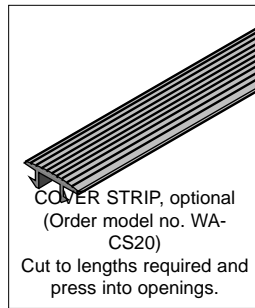

**Figure 8
INSTALLING CASTERS**

9. Install end caps and cover strip (Fig 9).

NOTE: Cover strip is optional extra and must be ordered separately (order number WA-CS20).

10. Check to make sure all bolts are tight and that unit is square (all four casters firmly on floor). Adjust as necessary.



**Figure 9.
COMPLETED UNIT**



Workplace Solutions

P.O. Box 26 • 600 South Clark St.
Mayville, WI 53050
Phone 920-387-5195