

Workplace Solutions



P.O. Box 26 • 600 South Clark St.  
Mayville, WI 53050  
Phone: 920-387-5195

For use on Wire Rope  
from 3/16"(5mm) thru 3/8"(9mm) O.D.

Includes Brass Hose Connector

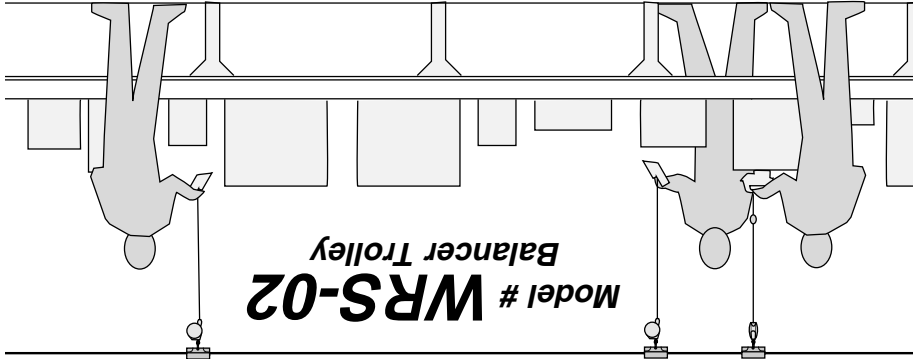

Model # **WRS-02**  
Balancer Trolley

### Contents: One model # WRS-02

Workstation trolley with hose connector.  
Provides convenient 1/4" air hose connector to  
control supply and drop hose. LABYRINTH hook  
design allows easy, safe balancer attachment.

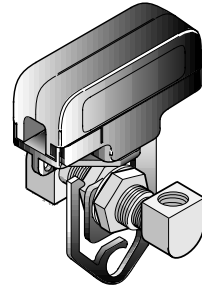

### 8 MODELS AVAILABLE

- |                                   |  |  |   |   |  |   |
|-----------------------------------|--|--|---|---|--|---|
|                                   |  |  |   |   |  |   |
| #WRS-01<br>Trolley with tool hook | #FRT-04<br>Trolley for round cable or hose, 0.3" to 0.6" OD. | #FRT-24<br>Trolley for two round cables or hoses, 0.3" to 0.6" OD. | #FRT-05<br>Trolley for round cable or hose, 0.6" to 0.94" OD. | #FRT-25<br>Trolley for two round cables or hoses, 0.6" to 0.94" OD. | #FRT-06<br>Trolley for round cable or hose, 0.95" to 1.25" OD. | #FFT-08<br>Trolley for flat cable to 2.1" wide. |

Products to make your workplace more efficient and safe.  
**Ask for FREE CATALOG.**

## • TROLLEY INSTALLATION •

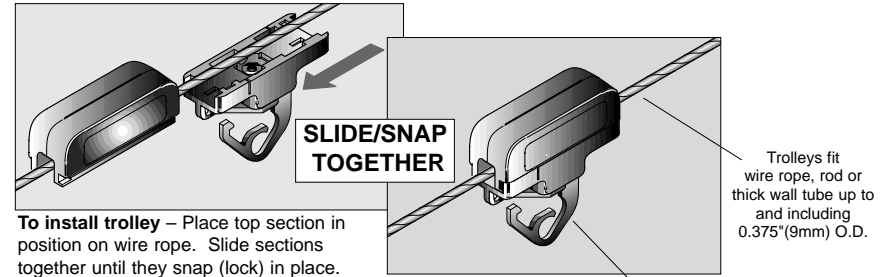

**To install trolley** – Place top section in position on wire rope. Slide sections together until they snap (lock) in place.  
**NOTE: Sections can be assembled in only one way. Slide "un-blocked" end into "un-blocked" end. Do not force.**

Trolleys fit wire rope, rod or thick wall tube up to and including 0.375"(9mm) O.D.

Labyrinth tool hook.

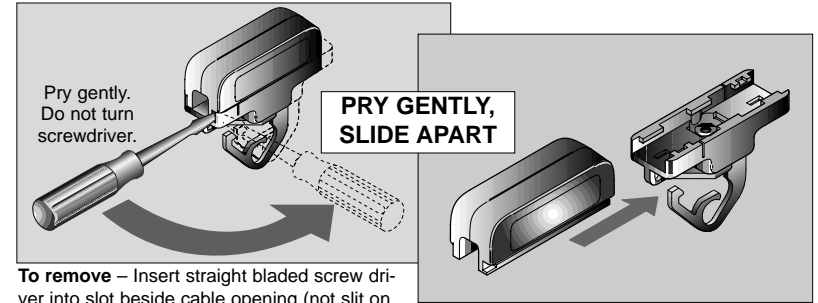

**To remove** – Insert straight bladed screw driver into slot beside cable opening (not slit on side of trolley) and pry gently as shown above. Do not turn screwdriver. **Slide Apart.**

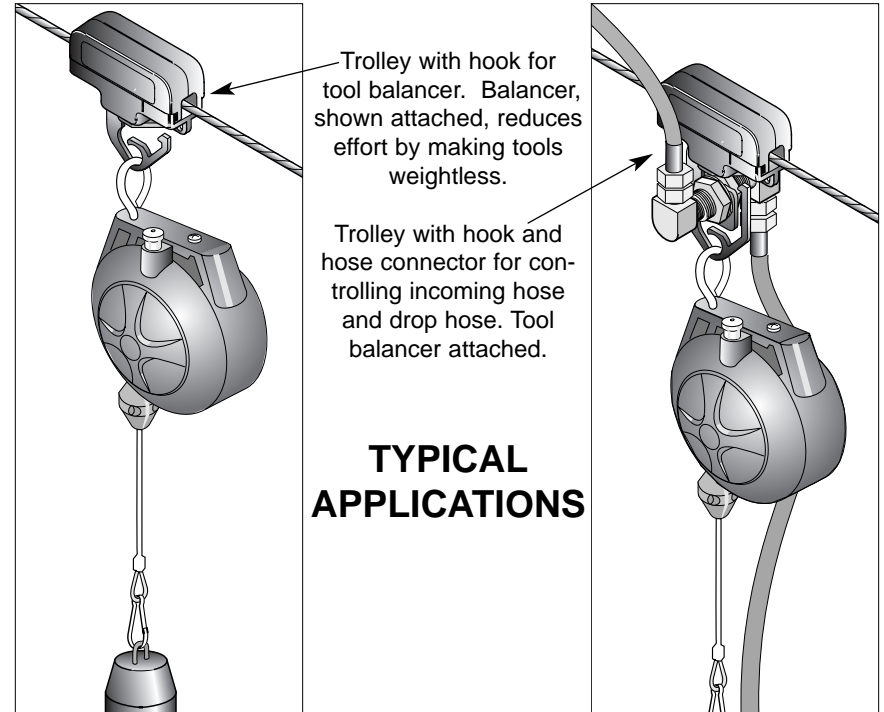

Trolley with hook for tool balancer. Balancer, shown attached, reduces effort by making tools weightless.

Trolley with hook and hose connector for controlling incoming hose and drop hose. Tool balancer attached.

### TYPICAL APPLICATIONS