

# HEAVY-DUTY TOOL RAIL HANGER

## 250 POUND CAPACITY HANDLES EVEN HEAVIEST TOOLS

Listed here are the components needed for a hanging 250 lb. capacity tool or festoon rail. Three of them are new... the WS60-MB Mounting Base, the WS60-HC Hanger Coupler, and the WS60-HW Bolt Kit. The rest are listed in WS-5 catalog. Thru bolts both top and bottom (see photo) act as a safety net. Thru bolts are included with the mounting bases. These components will not be sold as a kit because the galvanized C-60 Track, both vertical and horizontal, can vary greatly in length. Track must be supported every six feet to preserve 250 lb. capacity rating.

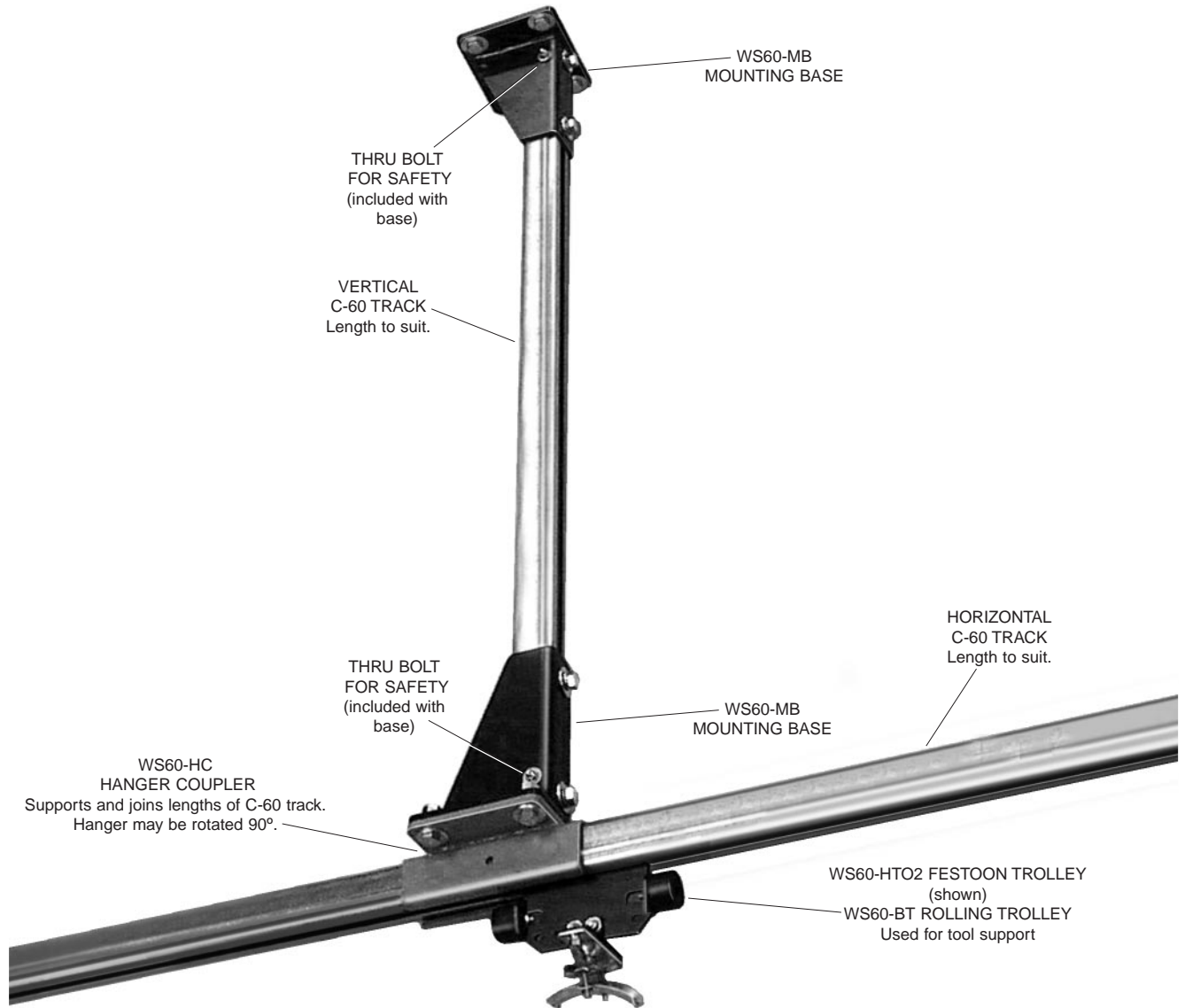

DESCRIPTION	MODEL NO.
Mounting Base for C-60 Track	WS60-MB
C-60 Hanger Coupler	WS60-HC
Hardware Kit*	WS60-HW

\*Hardware Kit includes (4) 1/2 x 1 1/2 bolts, nuts, lock washers and flat washers required to attach hanger coupler to mounting base.



**Workplace Solutions**

P.O. Box 26 • 600 South Clark St. • Mayville, WI 53050-0026 • Phone 920-387-5195