

SHELF FITS ANY UPRIGHT SPACING

POSITIVE FOUR POSITION TILT ADDS FLEXIBILITY

New design positions shelf in front of, not between, supporting uprights. This allows almost unlimited upright spacing, dictated by the bench design not shelf length. Shelf attaches to uprights with track nuts (like old style) and has adjustable tilt (also like old style). New design, however, features positive four position tilt with holes rather than slots. Brackets attach to shelf with track nuts into lateral rail welded to underside of shelf. Four models are available, fitting workstations with upright column center-to-center spacing to 68" (1727mm). Baked polyester finish is beige on shelf and matt black on brackets. Shelf includes black end caps.

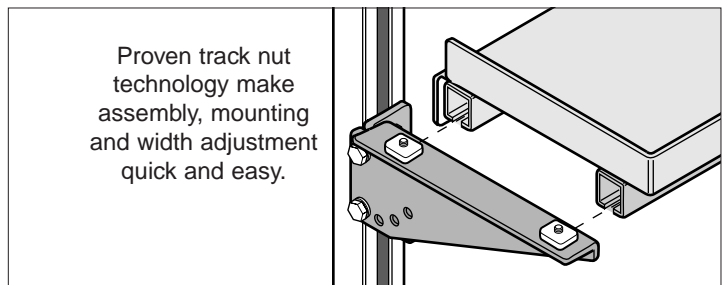
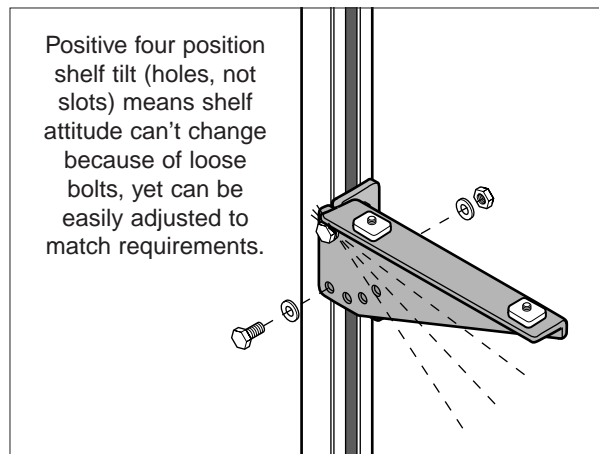
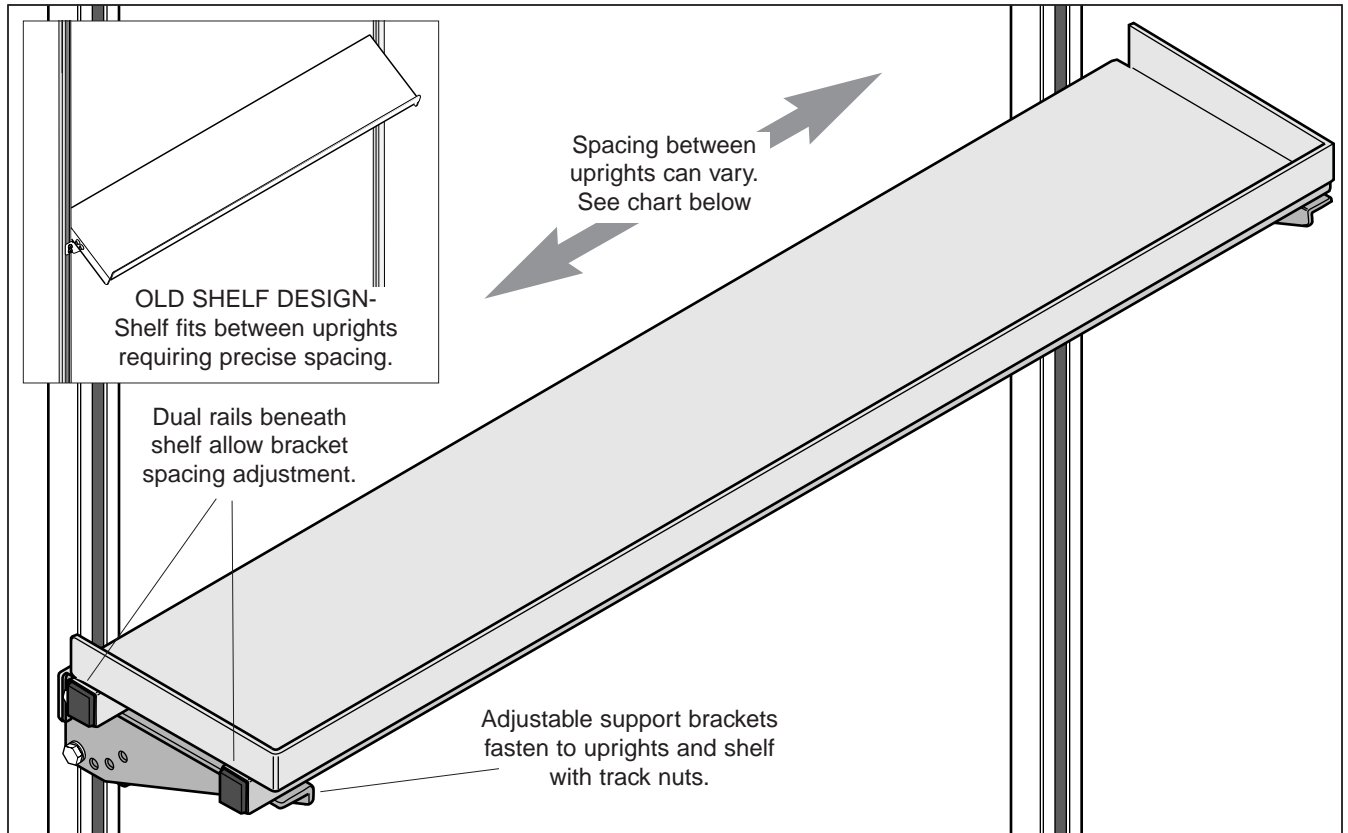

MODEL NUMBER	MAX. UPRIGHT SPACING center-to-center	
WS50-SS03A	32"	(812mm)
WS50-SS04A	44"	(1117mm)
WS50-SS05A	56"	(1422mm)
WS50-SS06A	68"	(1727mm)



Workplace Solutions

P.O. Box 26 • 600 South Clark St. • Mayville, WI 53050-0026 • Phone 920-387-5195