

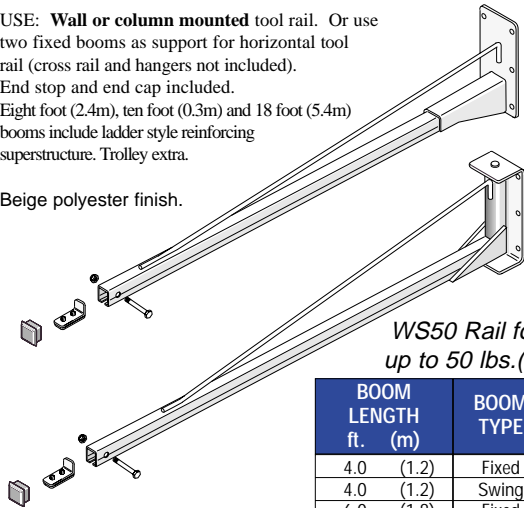

Workplace Solutions

FIXED OR 180° SWINGING WS50 BOOMS

USE: **Wall or column mounted** tool rail. Or use two fixed booms as support for horizontal tool rail (cross rail and hangers not included). End stop and end cap included. Eight foot (2.4m), ten foot (0.3m) and 18 foot (5.4m) booms include ladder style reinforcing superstructure. Trolley extra. Beige polyester finish.



WS50 Rail for loads up to 50 lbs. (22.5 kg)

| BOOM LENGTH ft. (m) | BOOM TYPE | MODEL NO. |
|---------------------|-----------|------------|
| 4.0 (1.2) | Fixed | #WF50-WS04 |
| 4.0 (1.2) | Swing | #WS50-WS04 |
| 6.0 (1.8) | Fixed | #WF50-WS06 |
| 6.0 (1.8) | Swing | #WS50-WS06 |
| 8.0* (2.4) | Fixed | #WF50-WS08 |
| 8.0* (2.4) | Swing | #WS50-WS08 |
| 10.0* (3.0) | Fixed | #WF50-WS10 |
| 10.0* (3.0) | Swing | #WS50-WS10 |
| 18.0* (5.4) | Swing | #WS50-WS18 |

*Features ladder style reinforcing rather than tie rod. Model WS50-WS18 has stacked (doubled) rail for additional strength.

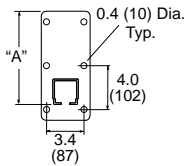

| TYPE | Dim. A in. (mm) |
|-------|-----------------|
| Swing | 8.12 (206) |
| Fixed | 7.75 (197) |

MOUNTING HOLE LAYOUT
4'-10' BOOMS

MOUNTING HOLE LAYOUT 18' BOOM

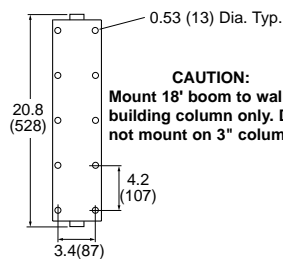

CAUTION:
Mount 18' boom to wall or building column only. Do not mount on 3" column.

Rail Mounted Fixed or Swing Booms

USE: **Tool rail mounted** to WS50 or WA50 vertical column. End stop, end cap, safety bolt and all hardware included. Trolley extra. Beige polyester finish.

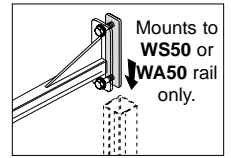
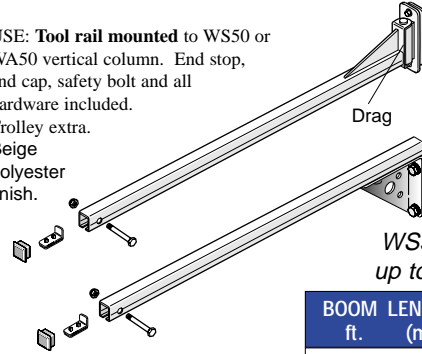

WS30 Rail for loads up to 30 lbs. (13.5 kg)

| BOOM LENGTH ft. (m) | BOOM TYPE | MODEL NO. |
|---------------------|-----------|------------|
| 3.0 (0.9) | Fixed | #WF30-DS03 |
| 3.0 (0.9) | Swing | #WS30-DS03 |

Wall Mounted Booms

USE: **Wall mounted** tool rail. End stop, end cap and safety bolt included. Trolley extra. Beige polyester finish

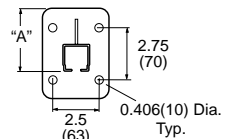
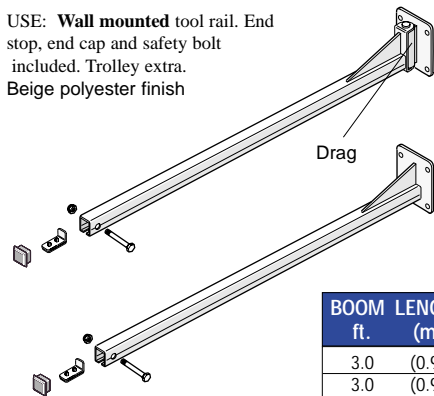

| TYPE | Dim. A in. (mm) |
|-------|-----------------|
| Swing | 3.38 (85) |
| Fixed | 3.19 (81) |

WS30 Rail for loads up to 30 lbs. (13.5 kg)

| BOOM LENGTH ft. (m) | BOOM TYPE | MODEL NO. |
|---------------------|-----------|------------|
| 3.0 (0.9) | Fixed | #WF30-WS03 |
| 3.0 (0.9) | Swing | #WS30-WS03 |

#WS-UB U-BOLT ASSEMBLY

USE: Secures 4'-10' booms or other flat plates to 3" dia. vertical column. Three required to mount boom. Do not use for mounting 18' boom (#WS50-WS18). Zinc plated steel



Bases and Supports

These bases are larger than those listed with the track components and are used primarily when a more rigid structure is desired. All bases include hardware for mounting rail to base.

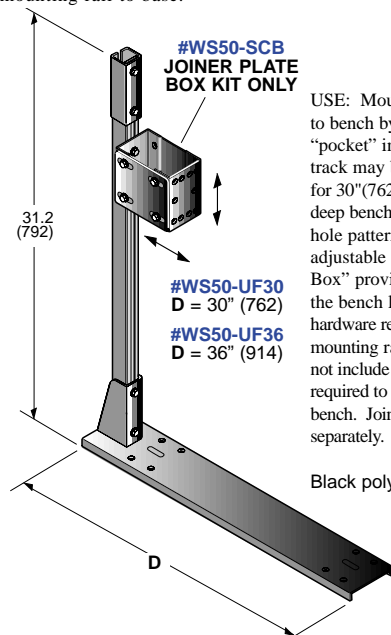

#WS50-SCB
JOINER PLATE
BOX KIT ONLY

#WS50-UF30
D = 30" (762)
#WS50-UF36
D = 36" (914)

BENCH LEG BASE

USE: Mounts workstation to bench by providing a "pocket" into which WS50 track may be fitted. Models for 30"(762) or 36"(914) deep benches. Universal hole pattern in foot plus adjustable "Joiner Plate Box" provide solid grip to the bench leg. Includes hardware required for mounting rail to base. Does not include hardware required to mount base to bench. Joiner plate box included and also available separately.

Black polyester finish.

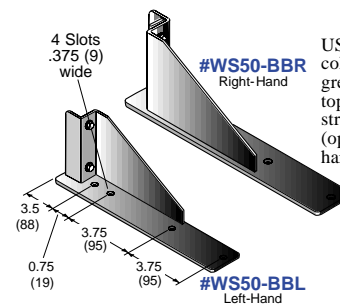
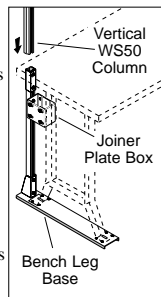

TABLE BRACKETS

Black polyester finish. USE: Mounts WS50 or WA50 vertical support columns to typical work bench. Provides greater rigidity when mounted to sheet metal tops than standard bases. For even greater strength, use model #WS50-BBS backing plate (optional) beneath bench top. Includes hardware for mounting rail to bracket. Does not include hardware for mounting base to bench.

SUPPORT CLAMP
WS50-SC-For WS50 (steel) Rail
WA50-SC-For WA50 (Aluminum) Rail
Black polyester finish.
USE: Fasten rail to back of bench for added stability. Typically used with WS50-MB base.
WS60-SC-For WS60 (steel) Rail
also available. Mounting dimensions differ from WS50-SC.

