

# **GLEASON** **PowerTrak**®

## ***Cable/Hose Carrier Reference Guide***

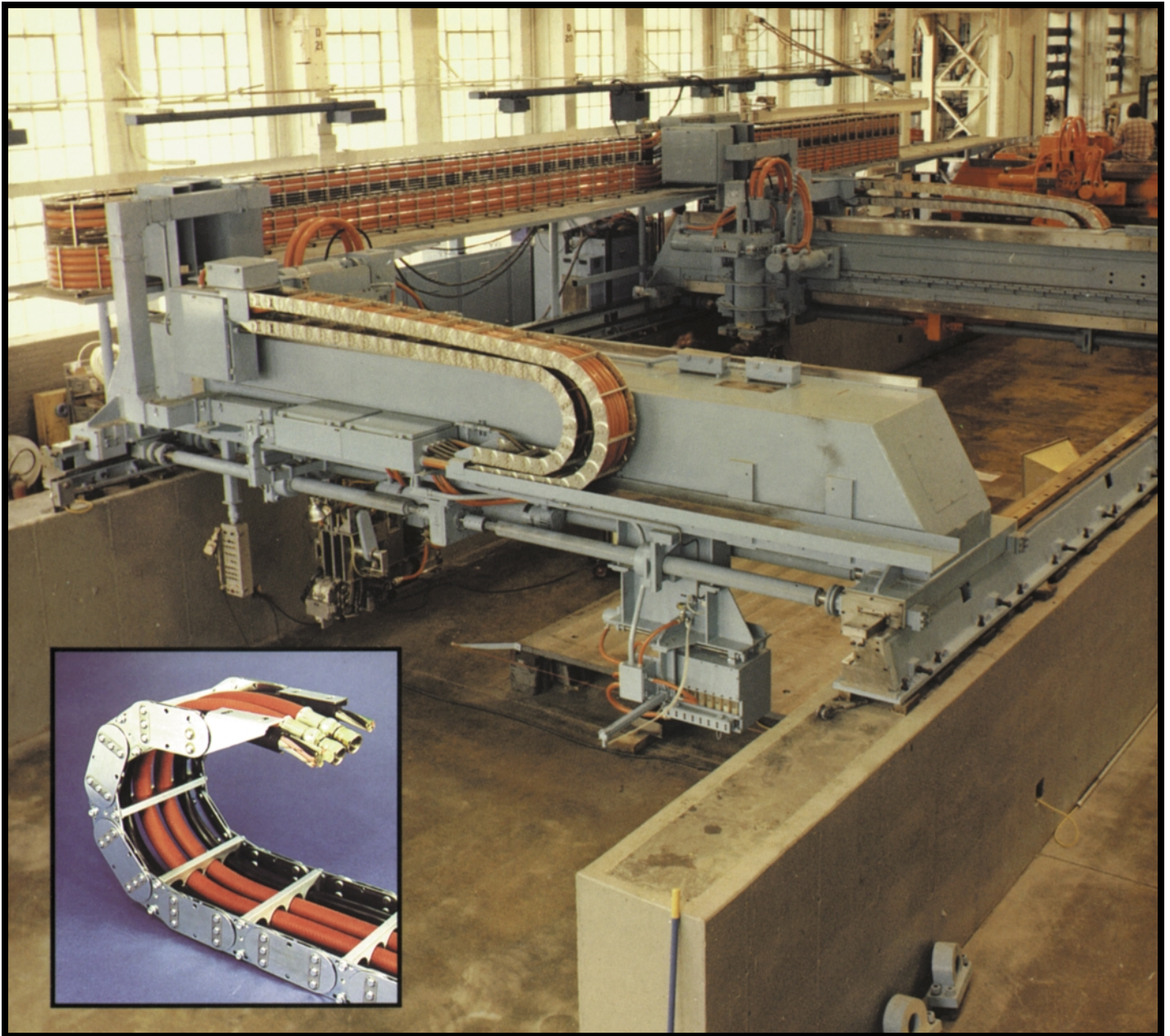

### ***Standard Duty, Heavy Duty and Mill Duty Steel Link PowerTrak***



# Where to Begin...

This catalog is organized to help you properly size and apply Type "E" PowerTrak.

1. Become familiar with the various ways in which PowerTrak can be applied, pages 5–7.
2. Pages 8 & 9 show the various carrier styles. Carriers separate the side links and support the cables/hoses.
3. Pages 10–23 provide dimensions and capacity data for the various types of PowerTrak and accessories.
4. Use pages 24–29 to develop the complete model number for the PowerTrak that best fits your needs.  
Use the Selection Guide (page 26), Weight Calculations (page 30) and Cable & Hose Data to help you.

FOR FURTHER ASSISTANCE, your local representative has a computerized PowerTrak Application program that will calculate the most logical model for your application based on data you provide.

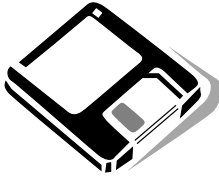

TO HELP YOU incorporate PowerTrak into your design, DXF and DWG files are available on disks. They are designed to eliminate the task of detailing PowerTrak on your drawings. In addition, the Gleason engineering staff is available to assist you with application or to generate custom Cad drawings to your specifications. Please contact Gleason for more information.

## Contents

<b>General Information</b>	<b>Page</b>
Construction and Features .....	.4
Applying PowerTrak .....	.5–7
Carrier Options .....	.8–9
Carriage Systems .....	.20–21
Accessories .....	.22
Cable/ Hose Clamps .....	.23
Cable Tie Strips .....	.23
<b>Technical Data</b>	<b>Page</b>
Dimensional Data by Size	
PT25E .....	.10
PT28E .....	.11
PT35E .....	.12
PT38E .....	.13
PT45E .....	.14
PT48E .....	.15
PT55E & PT55EF .....	.16
PT60E & PT60EF .....	.17
PT80E & PT80EF .....	.18
PT100E & PT100EF .....	.19
PowerTrak Carriage Systems .....	.20–21
Weights for all types .....	.30
Mounting Bracket Arrangements .....	.30
Cable & Hose Data .....	.31
<b>Ordering</b>	<b>Page</b>
Determining PowerTrak Size .....	.24–29
Travel Capability Tables .....	.25
PowerTrak Selection Guide .....	.26

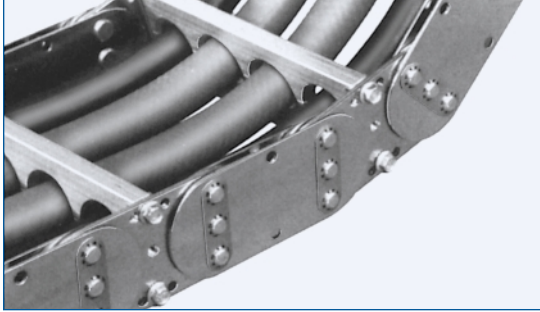

## STANDARD DUTY E-TYPE

**E**<sup>TYPE</sup>

**MODELS PT25E - PT48E**

Standard Duty PowerTrak (E-Type) offers outstanding value and high performance for industrial cable/hose protection on machinery in motion.

Features include high strength, low alloy flat link design, PowerTrak's unique anti-friction disc system for smooth operation and rugged, low-maintenance one-piece push-on fasteners.

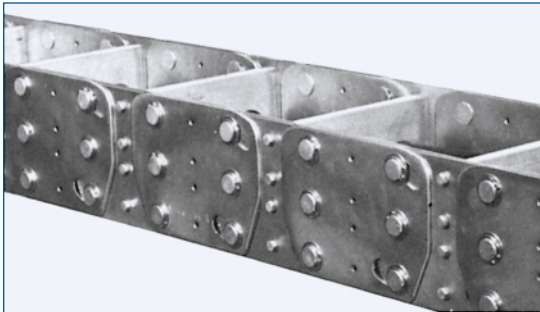

## HEAVY DUTY E-TYPE

**E**<sup>TYPE</sup>

**MODELS PT55E - PT100E**

Heavy Duty PowerTrak (E-Type) has a full range of sizes for LARGE cables and hoses.

A heavy gauge flat link is standard together with PowerTrak's unique anti-friction disc system and retaining ring fasteners. Heavy Duty PowerTrak may be used with roller supports for heavy loads and extended travel lengths.

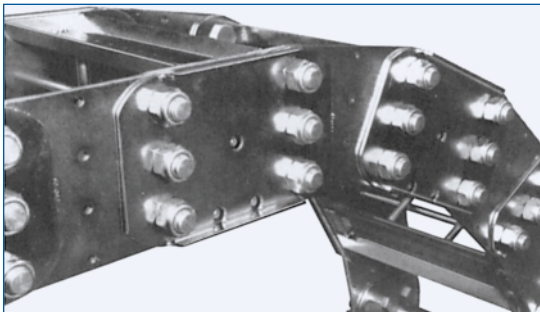

## MILL DUTY EF-TYPE

**EF**  
TYPE

**MODELS PT55EF - PT100EF**

Mill Duty PowerTrak (EF-Type) is designed with the most demanding industrial applications and harsh environments in mind.

Standard features include high strength, low alloy, heavy gauge steel links with reinforcing flanges, PowerTrak's self-lubricating system and bolted construction for maximum strength and serviceability.

*Also Available...*

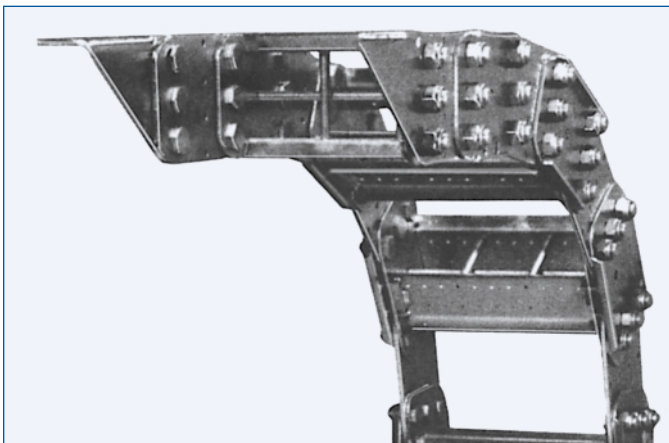

## SUPER DUTY EF-TYPE

**EF**  
TYPE

**MODELS PT120EF - PT240EF**

Super Duty PowerTrak (EF-Type) is available for Off-Shore Rigs and other applications where "oversized" cables and hoses are used.

Standard features include high strength, low alloy, heavy gauge steel links with reinforcing flanges, PowerTrak's self-lubricating system and bolted construction for maximum strength and serviceability.

**NOTE: Super Duty PowerTrak sizes are not detailed in this catalog. Please contact the factory for complete application information and product specifications.**



**SIDE CHAINS -**  
Two per trak

**MOUNTING BRACKETS -** Two pair per trak

**CARRIERS -**  
Many styles available

**HINGE PINS**

**CARRIER BOLTS**

**ANTI-FRICTION DISCS**

**LINKS**

**ONE-PIECE PUSH-ON FASTENERS**  
*Standard Duty Only*

## Standard Duty

**FOR RUGGED SERVICE  
MODELS PT25E - PT48E**

**High Strength Steel Links**  
Manufactured from high-strength, low-alloy steel, the highest material standard in the industry. Stainless steel links available for special needs.

**Anti-friction Discs**  
Unique discs placed between the links to reduce friction while at the same time permitting tighter tolerances. PowerTrak runs quietly and efficiently because the nylon used to make the discs is a natural bearing material. Extreme temperature discs are available for special requirements.

**Fasteners**  
Rugged hinge pins secured by ONE-PIECE, PUSH-ON FASTENERS. These unique fasteners *cannot be over tightened*.

**Flat Link Design**  
PowerTrak employs a 2:2 flat link design for maximum strength and durability. Two inner links are "sandwiched" between two outer links with Anti-friction Discs as bearing material.

## Heavy Duty

**FOR HEAVIER LOADS AND LARGER CABLES/HOSES  
MODELS PT55E - PT100E**

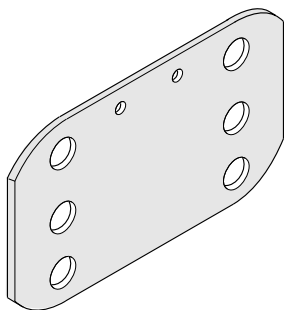

### TYPICAL APPLICATIONS

- Machine Tools
- Robotics
- Automated Stackers
- Rail Mounted Equipment
- Gas Cutting Torches
- Extending Arms
- Gantry Cranes
- Loaders
- Crane Service
- Shuttle Cars

## E-TYPE

### STANDARD FEATURES

- 2:2 Flat Link Design
- Retaining Ring Fasteners
- High Strength, Low Alloy Steel Construction
- Anti Friction Discs
- Multiple Carrier Types
- Full Range of Sizes
- Multiple Radii
- Variable Widths

### OPTIONAL FEATURES

- Bolted Construction (*EB-Type*)
- Available for Extended Travel
- Available for High Speeds
- Roller Supports for Extended Travel Lengths
- Sliding Mounting Brackets

## Mill Duty

**OPTIONAL CONSTRUCTION FOR ALL HEAVY DUTY  
MODELS PT55EF - PT100EF**

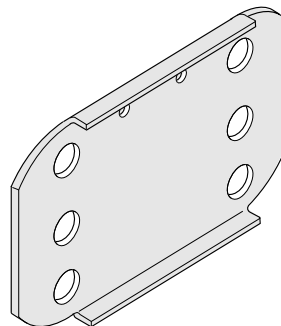

### TYPICAL APPLICATIONS

- Heavy Machines
- Automated Stackers
- Equipment Moving on Rails
- Gas Cutting Torches
- Extending Arms
- Gantry Cranes
- Harsh Environments
- Off-Shore Rigs

## EF-TYPE

### STANDARD FEATURES

- 2:2 FLANGED Link Design
- Bolted Construction
- High Strength, Low Alloy Steel Construction
- Anti Friction Discs
- Multiple Carrier Types
- Full Range of Sizes
- Multiple Radii
- Variable Widths

### OPTIONAL FEATURES

- Retaining Ring Fasteners (*EFP-Type*)
- High-Temp Anti-Friction Discs
- Sliding Mounting Brackets (for high pressure hoses, etc.)
- Roller Supports for Extended Travel Lengths

# Applying type “E” PowerTrak®

PowerTrak is most often used in the horizontal Standard Travel configurations, described on this page. TWO-WAY PAYOUT is normally used with Standard Travel.

Two-way payout means locating the cable/hose source at the CENTER of machine travel so that cables/hoses are used in TWO directions. Thus, using two-way payout, the PowerTrak you order will be just one-half of the Total Travel distance that you require, plus a little more to form the curve, as illustrated below.



## STANDARD TRAVEL

- Two-way payout (center-fed)
- Upper section is self-supported, roller supported, or for extended travel, may ride on itself or on a carriage
- Lower section is supported by a surface

## Adding Roller Supports

Roller supports present a useful option when applying PowerTrak. While larger sizes of PowerTrak have greater Total Travel capabilities, smaller sizes can have their capabilities increased by adding roller supports.

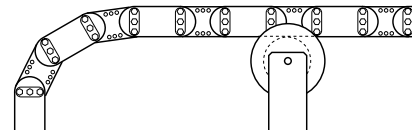

Stationary roller supports increase the travel or weight capacity capabilities of PowerTrak by supporting the upper, or “free hanging” section.

## STANDARD TRAVEL Plus ONE Roller

- Two-way payout (center-fed)
- Upper section is supported by ONE roller support
- Lower section is supported by a surface
- ➔ Total Travel capability increases by 50%

## STANDARD TRAVEL Plus TWO Rollers

- Two-way payout (center-fed)
- Upper section is supported by TWO roller supports
- Lower section is supported by a surface
- ➔ Total Travel capability increases by 100% (doubles)

## Variations

Opposed Travel is the most common variation to Standard Travel. Two smaller PowerTraks in the Opposed configuration can do the same work as a larger size using Standard Travel. Opposed Travel is a valid option when there are width restrictions or when cables and hoses must be separated.



Opposed Travel involves TWO PowerTraks opposed to one another, each operating in the Standard Travel configuration. Cables/hoses are distributed between the two PowerTraks increasing operating life. Length of each trak is same as one standard travel trak in given application, but type and width of trak may be smaller.

## OPPOSED TRAVEL

- TWO PowerTraks, two-way payout on each
- Upper sections self-supported or may ride on lower section or carriage
- Lower sections are supported by a surface
- Roller supports are not available
- ➔ Overall width may be reduced
- ➔ Cables and hoses may be separated

# Other Variations

## One-Way Travel

Applied where situation prohibits center-feeding of cables/hoses. Roller supports may be added to increase Total Travel capabilities.

- ONE-WAY payout (end-fed in relation to machine travel)
- Upper section is SELF-SUPPORTING
- Lower section is supported by a surface
- Roller supports may be added — consult factory

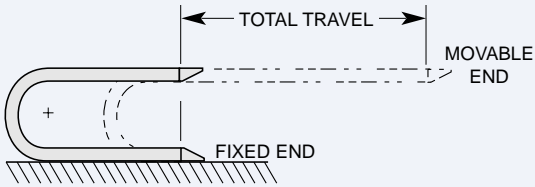

## Nested Travel

Two PowerTraks having different bend radii allowing one to nest within the other. Cables/hoses are distributed between the two PowerTraks increasing operating life.

- TWO PowerTraks, two-way payout on each
- Upper sections must be SELF-SUPPORTING
- Lower sections are supported by a guide tray
- Both PowerTraks must be same width
- ⇒ Overall width may be reduced
- ⇒ Cables and hoses may be separated

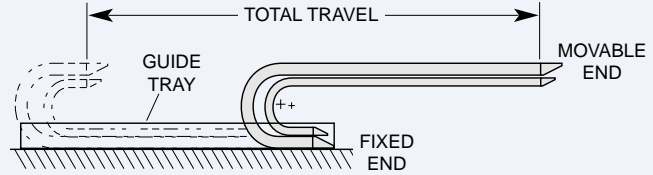

## CURVE AT TOP

## Vertical Travel

Vertical Travel in the Curve at Top or Curve at Bottom configuration is possible when PowerTrak is properly supported:

- A back-up SURFACE ① is preferred for one side of the PowerTrak.
- A back-up PLATE ② must extend a minimum of four (4) links.

- Typically two-way payout (center-fed)
- Back-up surface ① and back-up plate ② used to support PowerTrak
- ⇒ Curve at Bottom provides greater Total Travel capabilities than Curve at Top.

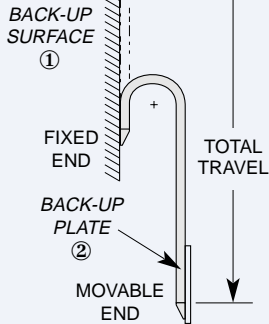

## CURVE AT BOTTOM

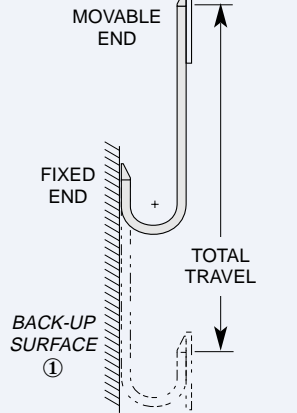

## Lift

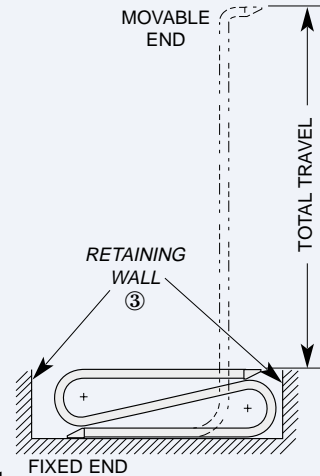

Lifting is possible when PowerTrak is properly supported:

- Vertical retaining walls Æ extending the full height of PowerTrak in the stored position are required.

- ONE-WAY payout
- END-FED (“Bottom Fed”) in relation to machine travel
- Upper section is SELF-SUPPORTING
- Lower section is fully supported
- Vertical retaining walls ③ required
- Special reverse bend links are required

## Combination Travel

PowerTrak can travel the full vertical and horizontal range of motion illustrated.

- Vertical & horizontal payout
- Typically CENTER-FED
- Upper section is SELF-SUPPORTING
- Lower section is fully supported

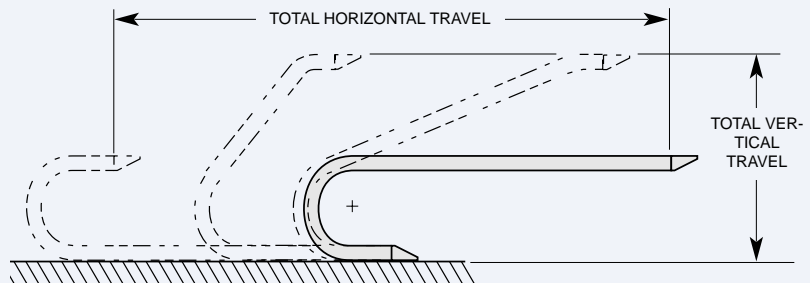

# Other Variations

## Linked Side-by-side Travel

PowerTrak side chains may be modified to allow for Double-Wide or Triple-Wide configurations. Contiguous Travel is a useful option when PowerTrak exceeds its Total Travel capabilities in the Standard Travel configuration.

- TWO or THREE PowerTraks, two-way payout on each
- Upper sections are self-supporting
- Lower sections are supported by a surface
- Not for use with all carriers. Consult factory.
- ⇒ Overall height may be reduced
- ⇒ Cables and hoses may be separated

**DOUBLE-WIDE**

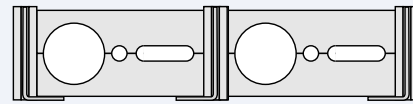

**TRIPLE-WIDE**

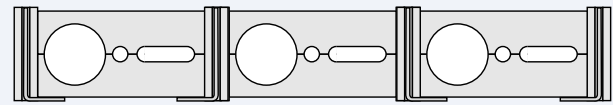

## Traveling on Edge

PowerTrak will travel on its edge with the addition of a guide tray. Edge-travel distributes cable/hose weight over a greater support area for improved life expectancy and is typically chosen when height restrictions apply.

- Two-way payout (center-fed)
- PowerTrak is fully supported by guide tray
- ⇒ Overall height may be reduced
- ⇒ Improved life expectancy for PowerTrak

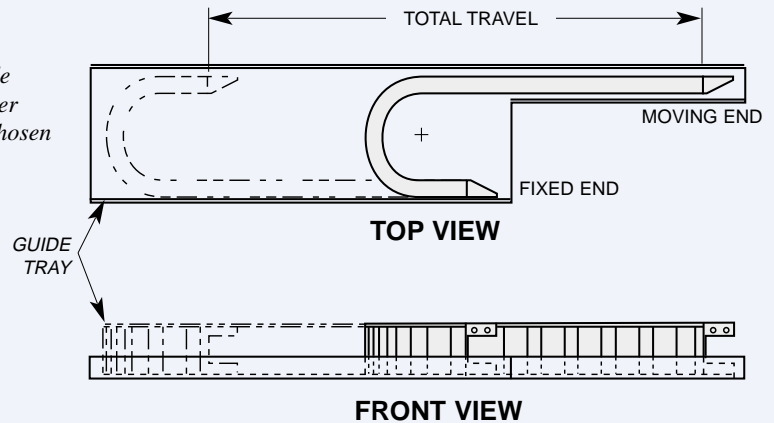

## Circular Travel

Circular Travel is possible when PowerTrak is modified to bend in two directions. PowerTrak travels on its edge on a two-piece, circular guide tray. The inner tray (light shading) rotates while the outer tray (dark shading) remains fixed. TYPICAL APPLICATIONS INCLUDE stacker cranes and stacker-reclaimer machines.

- Typically two-way payout (center-fed)
- PowerTrak is fully supported by guide tray
- Two-piece Guide Tray for free rotation
- PowerTrak is modified to bend in two directions

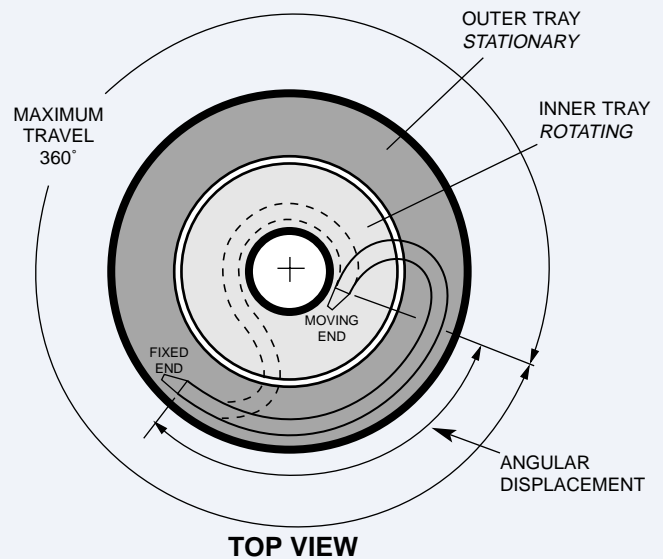

# Carrier Options

## Standard Duty – Sizes 25E - 48E

### TYPE BC MACHINED BAR CARRIER

**Most efficient carrier design available.** Machined aluminum bar provides maximum protection for cables and hoses in PowerTrak® by placing each, regardless of size, on a common centerline. Removable two-piece bar allows easy access.

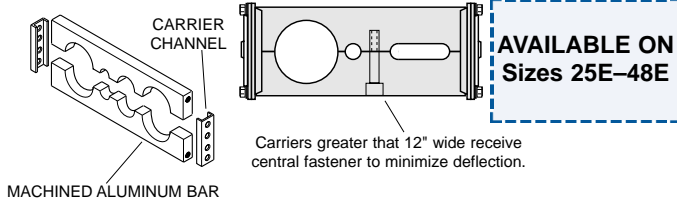

### TYPE RR REMOVABLE ROD CARRIER

Sold as a set, the removable rod, or "quick access" carrier, features a removable ROLLING rod on top and an aluminum channel on the bottom. The rod is spring-loaded for quick removal using a standard screwdriver and is securely fixed when in use. **The rolling rod reduces wear on cables/hoses.** Type RR carriers are limited to a width of 10".

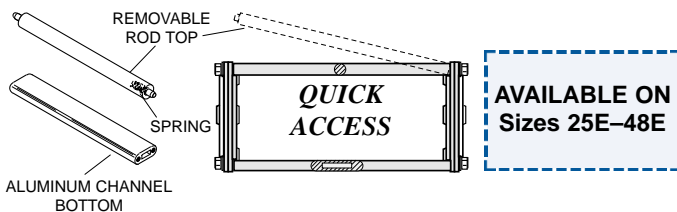

### TYPES AC & A1\* (A2\*, A3\*, etc.) ALUMINUM CHANNEL CARRIER

Aluminum channel carrier features a **wide support area and light weight.** Four-point fastening on both channels creates an **extremely rigid and stable** PowerTrak®, rivaling welded carriers. Type A1 (A2, A3, etc.) includes molded nylon separator(s) which may be positioned to prevent cable/hose entanglement and allow grouping of various types of conductors.

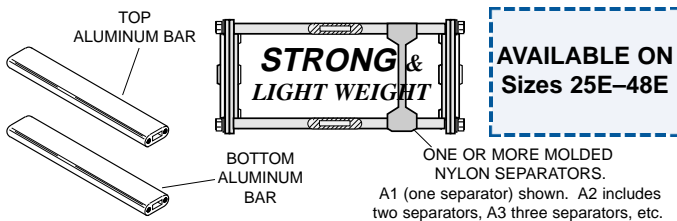

### TYPE SS STEEL STRAP CARRIER

Largest window area of any carrier makes the steel strap an alternative for cables/hoses with large outside diameters. When SS carrier is used, Total Travel of the trak is limited to 70% of the TT values listed in Tables 1-3 in the "Sizing" section. Type SS carriers are limited to a width of 10.00".



### TYPE SR STEEL ROD CARRIER

Provides basic support for cables and hoses. Steel rods are **economical, light weight and are easily removed** for cable/hose access.

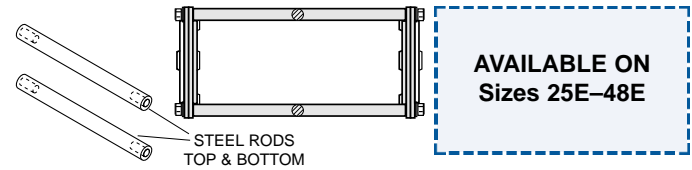

### TYPE R1\* (R2\*, R3\*, etc.) STEEL ROD CARRIER with NYLON SEPARATORS

**Tough molded nylon separators** provide partitions to prevent cable/hose entanglement and allow conductor grouping. One or more separators may be used as needed. Spacing of separators adjustable along complete length of rods.

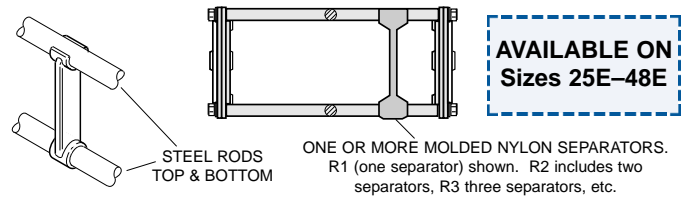

### TYPE RN STEEL ROD CARRIER with NYLON SLEEVES

Nylon sleeves roll when in contact with jacketed cable and hoses, increasing useful carrier life and decreasing wear to cables and hoses.

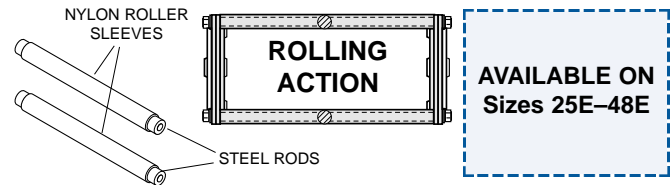

### FIXED TYPES RB & RB1\* (RB2\*, RB3\*, etc.) TWIST-OUT TYPES TRB & TR1\* (TR2\*, TR3\*, etc.) ALUMINUM CHANNEL CARRIER with NYLON ROLLERS

**The ultimate carrier.** Cables and hoses move smoothly on top and bottom nylon rollers. Available in either fully bolted design or with one twist-out bar to facilitate cable/hose installation.

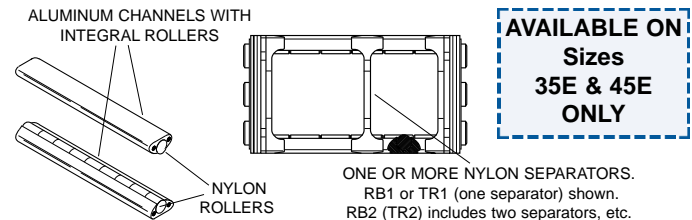

### CUSTOM DESIGNED CARRIERS WITH HORIZONTAL SEPARATORS

**Horizontally divided carriers** are desirable when very large and very small cables are mixed within the carrier or when there are numerous small cables/hoses. Consult factory for more information.

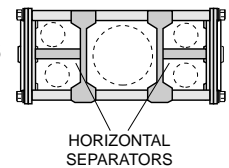

\* Numeral denotes number of vertical separators.



# Carrier Options

## Heavy Duty—Sizes 55E - 100E

## Mill Duty—Sizes 55EF - 100EF

### TYPE BC MACHINED BAR CARRIER

Most efficient carrier design available. Machined aluminum bar provides maximum protection for cables and hoses in PowerTrak® by placing each, regardless of size, on a common centerline. Removable two-piece bar allows easy access.

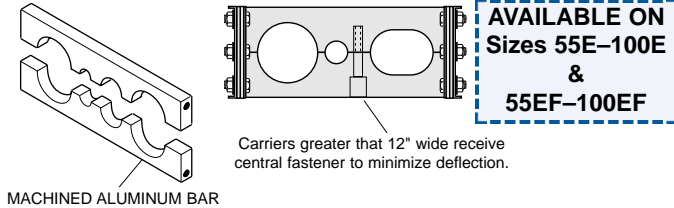

### TYPE WC WELDED CHANNEL CARRIER

Welded channels combine "brute strength" and a large surface area for cable/hose contact. The top channel is easily removed for immediate access to cables/hoses. The bottom channel is fixed.

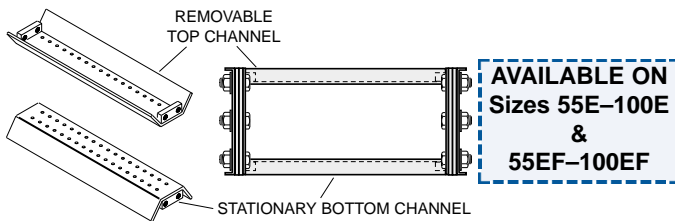

### TYPES WV1\* (WV2\*, WV3\*, etc.) WELDED CHANNEL CARRIER with MULTIPLE VERTICAL SEPARATORS

Multiple vertical separators may be added to the welded channel carriers. They are adjustable in one inch increments allowing precise grouping of cables and hoses. Vertical separators have a rolling action which prolongs cable/hose life.

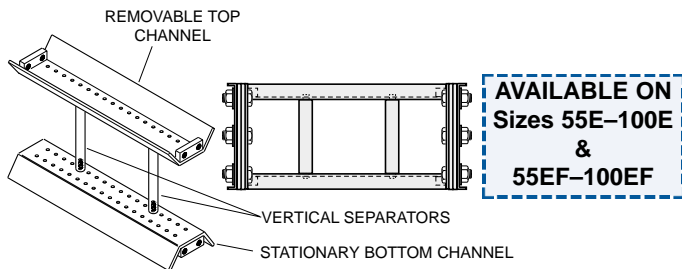

\* Numeral denotes number of vertical separators.

### TYPE WH WELDED CHANNEL CARRIER with ONE HORIZONTAL SEPARATOR

A single centrally located horizontal separator allows cable/hose grouping into two "compartments". Horizontal separators are fixed and *only one* may be used per welded channel carrier.

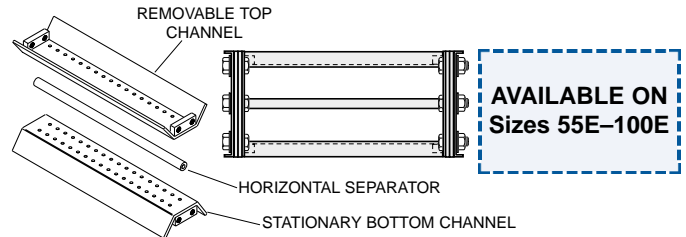

### TYPE HN ONE HORIZONTAL SEPARATOR with NYLON SLEEVE

Nylon sleeve can be added to the horizontal separator of a welded channel carrier. The nylon sleeve rotates freely over the separator giving it a rolling action which prolongs cable/hose life.

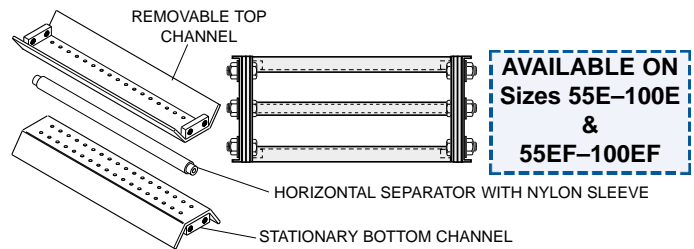

### TYPES HV1\* (HV2\*, HV3\*, etc.) ONE HORIZONTAL SEPARATOR and MULTIPLE VERTICAL SEPARATORS

Combines vertical and horizontal separators for complex grouping of cables and hoses. The horizontal separator is fixed (one only) while multiple vertical separators have a rolling action.

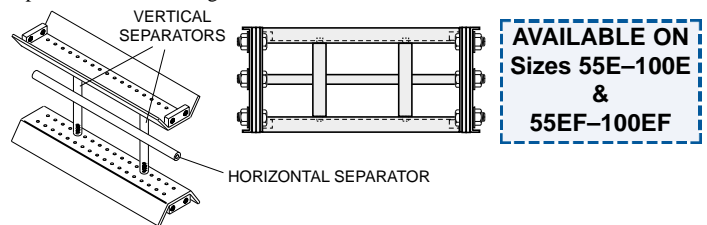

### TYPES NV1\* (NV2\*, NV3\*, etc.) ONE HORIZONTAL SEPARATOR with NYLON SLEEVE and MULTIPLE VERTICAL SEPARATORS

Nylon sleeve can be added to the horizontal separator giving it a rolling action which prolongs cable/hose life.

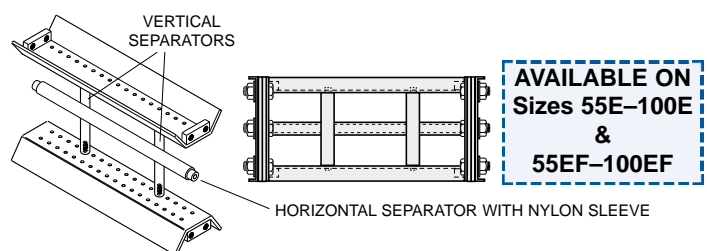

- Standard Duty
- High Strength, Low Alloy Steel
- E-type Standard Duty Links
- Rugged One-piece Push-on Fasteners
- Standard or Custom Radii
- Total Travel w/o Supports = 20.0 ft. ①
- Maximum Speed = 300 fpm
- Maximum Acceleration = 5.0 ft/sec<sup>2</sup>
- Maximum Cable/Hose O.D. = 1.11"
- PowerTrak Weight Unloaded = 3.04lbs/ft. ②

### GENERAL LAYOUT

(Dimensions in Inches unless otherwise specified)

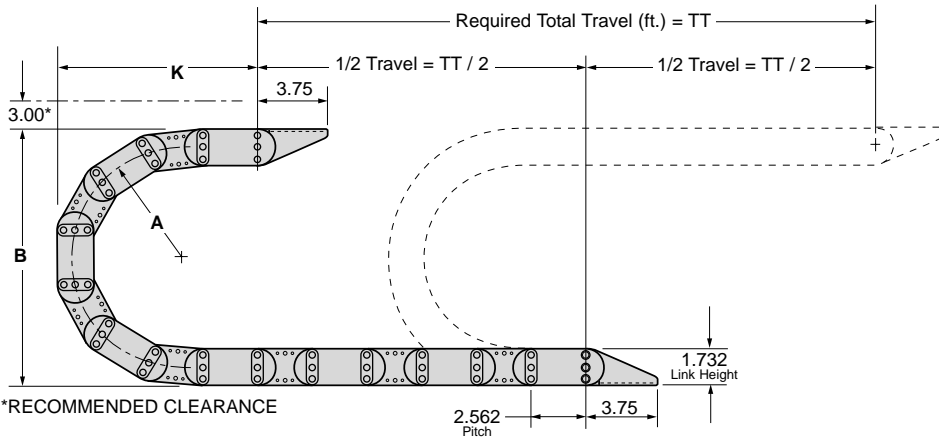

### MOUNTING BRACKETS

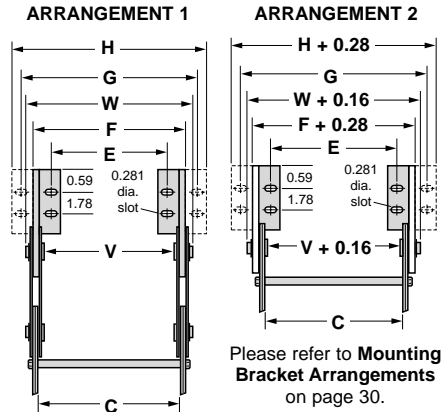

Radius A	Height B	Minimum K	Curve L ④
2.95	7.63	8.19	1.5 ft.
5.16	12.06	9.94	2.0 ft.
8.00	17.75	14.30	3.0 ft.
11.72	25.17	15.18	3.5 ft.

Carrier Width C	Feet Turned IN		Feet Turned OUT	
	Mtg. Location E ± .44	Brkt. O/A F ± .070	Mtg. Location G ± .44	Brkt. O/A H
4.00	3.19	4.24	5.44	6.38
6.00	5.19	6.24	7.44	8.38
8.00	7.19	8.24	9.44	10.38
10.00	9.19	10.24	11.44	12.38
12.00	11.19	12.24	13.44	14.38
FORMULA	C - .81	C + .24	C + 1.44	C + 2.38

Required Length (ft.)<sup>③</sup> =  $\frac{TT}{2} + L$

### NOTES REGARDING TRAK

- ① Based on standard travel with cable/hose package weight of 2.00 lbs/ft.
- ② Based on average carrier weight @ 8.00" width. For detailed information, please see "Weight Calculations".
- ③ Based on standard travel, i.e. two-way payout as pictured above.
- ④ L = minimum length in FEET required to form PowerTrak curve.

### CABLE/HOSE CARRIER OPTIONS (Dimensions in Inches)

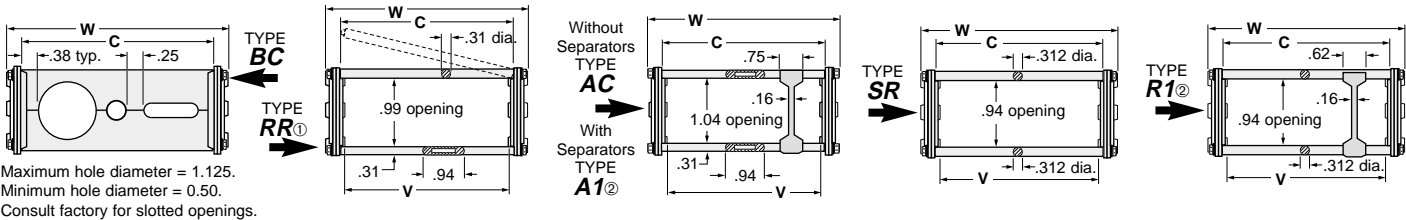

Maximum hole diameter = 1.125.  
Minimum hole diameter = 0.50.  
Consult factory for slotted openings.

Carrier Width C	Usable Window Width V	Overall PowerTrak Width W
4.00	3.75	4.72
6.00	5.75	6.72
8.00	7.75	8.72
10.00	9.75	10.72
12.00	11.75	12.72
Formula	C - .25	C + 0.72

### NOTES REGARDING CARRIERS

- ① Carrier types RR and SS limited to "C" dimension no greater than 10.00".
- ② Numeral "1" refers to number of vertical separators desired (2 = two separators, 3 = three separators, etc.). Number must be included in the model number when ordering.

- Standard Duty
- High Strength, Low Alloy Steel
- E-type Standard Duty Links
- Rugged One-piece Push-on Fasteners
- Standard or Custom Radii

- Total Travel w/o Supports = 22.0 ft. ①
- Maximum Speed = 300 fpm
- Maximum Acceleration = 5.0 ft/sec<sup>2</sup>
- Maximum Cable/Hose O.D. = 1.36"
- PowerTrak Weight Unloaded = 3.64 lbs/ft. ②

### GENERAL LAYOUT

(Dimensions in Inches unless otherwise specified)

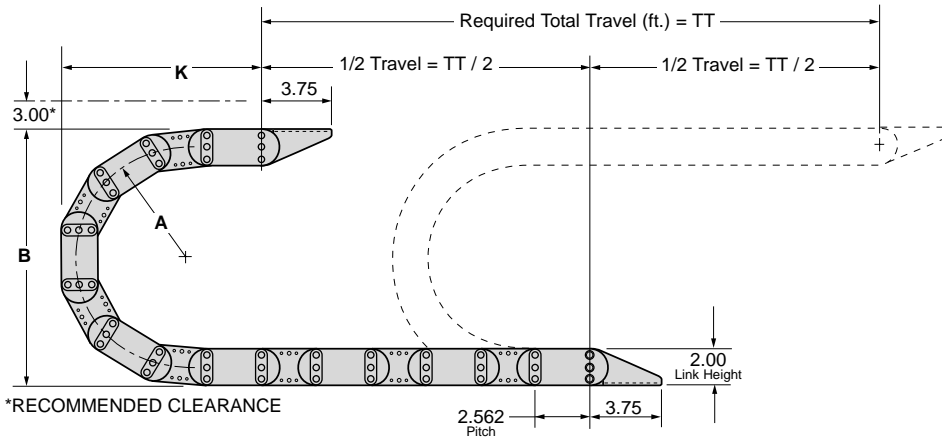

### MOUNTING BRACKETS

#### ARRANGEMENT 1

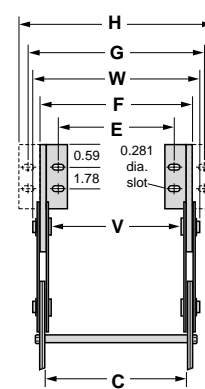

#### ARRANGEMENT 2

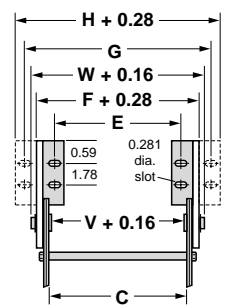

Please refer to Mounting Bracket Arrangements on page 30.

Radius A	Height B	Minimum K	Curve L ④
2.95	7.90	8.31	1.5 ft.
4.53	11.06	10.42	2.0 ft.
6.10	14.20	12.52	2.5 ft.

Carrier Width C	Feet Turned IN		Feet Turned OUT	
	Mtg. Location E ± .44	Brkt. O/A F ± .070	Mtg. Location G ± .44	Brkt. O/A H
4.00	3.19	4.24	5.44	6.38
6.00	5.19	6.24	7.44	8.38
8.00	7.19	8.24	9.44	10.38
10.00	9.19	10.24	11.44	12.38
12.00	11.19	12.24	13.44	14.38
FORMULA	C - .81	C + .24	C + 1.44	C + 2.38

Required Length (ft.) ③ =  $\frac{TT}{2} + L$

### NOTES REGARDING TRAK

- ① Based on standard travel with cable/hose package weight of 2.00 lbs/ft.
- ② Based on average carrier weight @ 8.00" width. For detailed information, please see "Weight Calculations".
- ③ Based on standard travel, i.e. two-way payout as pictured above.
- ④ L = minimum length in FEET required to form PowerTrak curve.

### CABLE/HOSE CARRIER OPTIONS (Dimensions in Inches)

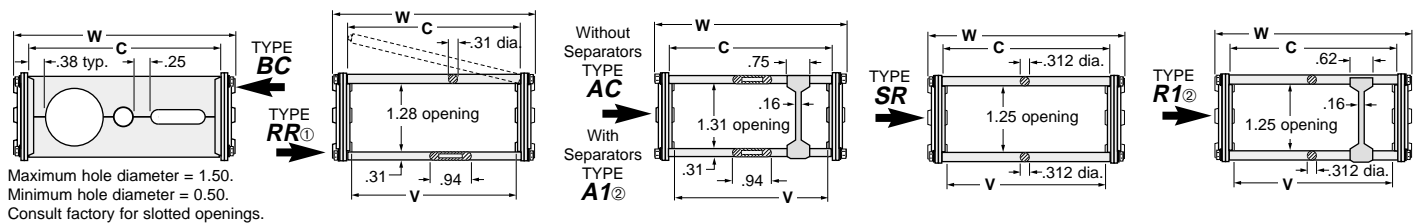

Carrier Width C	Usable Window Width V	Overall PowerTrak Width W
4.00	3.69	5.01
6.00	5.69	7.01
8.00	7.69	9.01
10.00	9.69	11.01
12.00	11.69	13.01
Formula	C - .31	C + 1.01

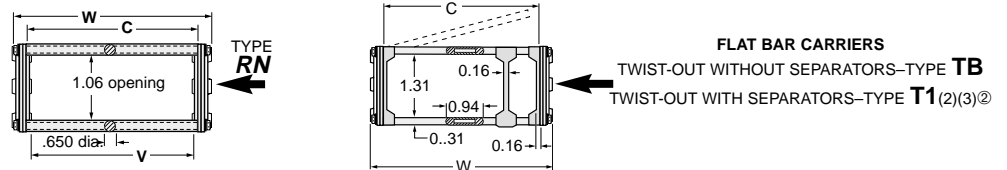

### NOTES REGARDING CARRIERS

- ① Carrier type RR limited to "C" dimension no greater than 10.00".
- ② Numeral "1" refers to number of vertical separators desired (2 = two separators, 3 = three separators, etc.). Number must be included in the model number when ordering.

- Standard Duty
- High Strength, Low Alloy Steel
- E-type Standard Duty Links
- Rugged One-piece Push-on Fasteners
- Standard or Custom Radii

- Total Travel w/o Supports = 28.0 ft. ①
- Maximum Speed = 400 fpm
- Maximum Acceleration = 5.0 ft/sec<sup>2</sup>
- Maximum Cable/Hose O.D. = 1.92"
- PowerTrak Weight Unloaded = 4.53 lbs/ft. ②

### GENERAL LAYOUT

(Dimensions in Inches unless otherwise specified)

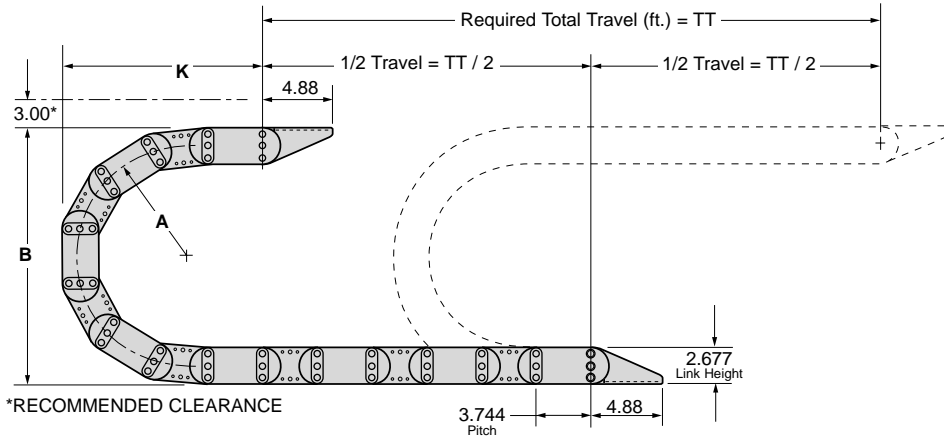

### MOUNTING BRACKETS

#### ARRANGEMENT 1

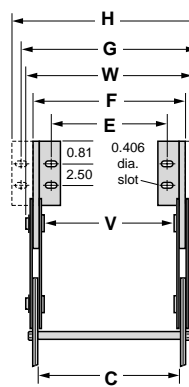

#### ARRANGEMENT 2

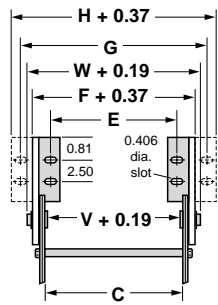

Please refer to Mounting Bracket Arrangements on page 30.

Radius A	Height B	Minimum K	Curve L ④
5.22	13.12	10.36	2.0 ft.
7.50	17.68	15.06	3.0 ft.
11.12	24.93	19.00	4.0 ft.
15.00	32.68	22.78	5.0 ft.
24.31	51.31	29.47	7.0 ft.

Required Length (ft.)<sup>③</sup> =  $\frac{TT}{2} + L$

Carrier Width C	Feet Turned IN		Feet Turned OUT	
	Mtg. Location E ± .38	Brkt. O/A F ± .070	Mtg. Location G ± .38	Brkt. O/A H
4.00	2.00	4.30	6.69	8.14
6.00	4.00	6.30	8.69	10.14
8.00	6.00	8.30	10.69	12.14
10.00	8.00	10.30	12.69	14.14
12.00	10.00	12.30	14.69	16.14
14.00	12.00	14.30	16.69	18.14
16.00	14.00	16.30	18.69	20.14
FORMULA	C - 2.00	C + .30	C + 2.69	C + 4.14

### NOTES REGARDING TRAK

- ① Based on standard travel with cable/hose package weight of 2.00 lbs/ft.
- ② Based on average carrier weight @ 8.00" width. For detailed information, please see "Weight Calculations".
- ③ Based on standard travel, i.e. two-way payout as pictured above.
- ④ L = minimum length in FEET required to form PowerTrak curve.

### CABLE/HOSE CARRIER OPTIONS (Dimensions in Inches)

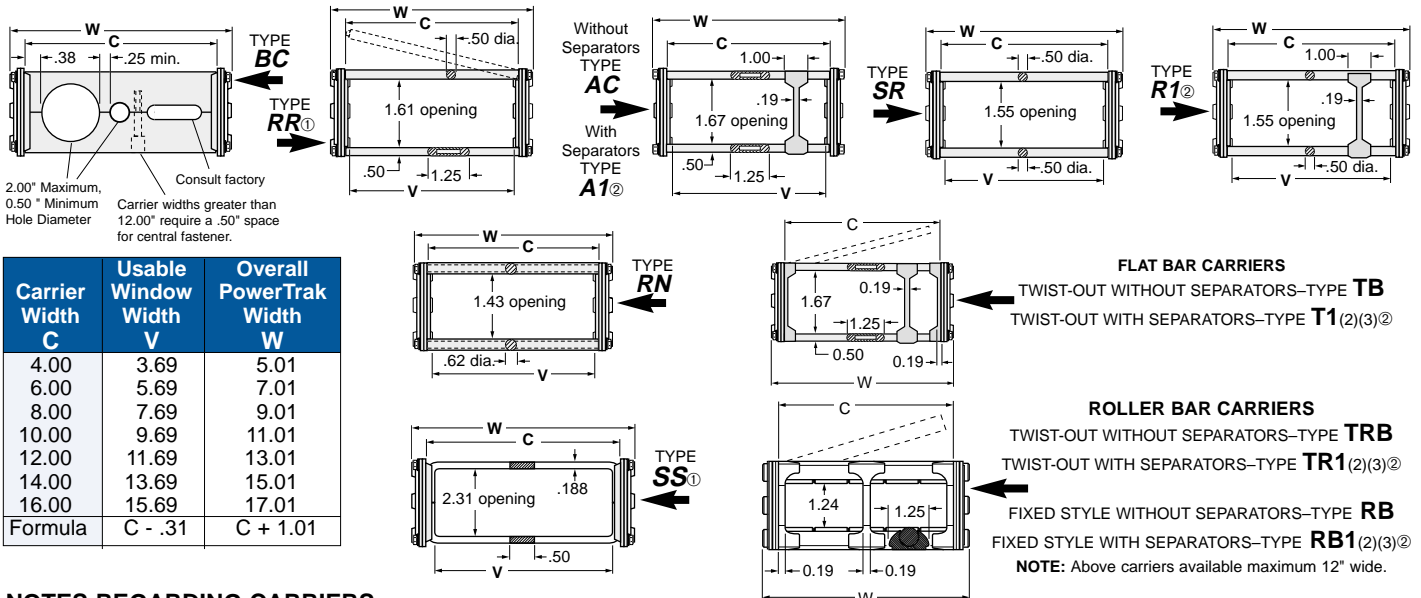

Carrier Width C	Usable Window Width V	Overall PowerTrak Width W
4.00	3.69	5.01
6.00	5.69	7.01
8.00	7.69	9.01
10.00	9.69	11.01
12.00	11.69	13.01
14.00	13.69	15.01
16.00	15.69	17.01
Formula	C - .31	C + 1.01

### NOTES REGARDING CARRIERS

- ① Carrier types RR and SS limited to "C" dimension no greater than 10.00".
- ② Numeral "1" refers to number of vertical separators desired (2 = two separators, 3 = three separators, etc.). Number must be included in the model number when ordering.



- Standard Duty
- High Strength, Low Alloy Steel
- E-type Standard Duty Links
- Rugged One-piece Push-on Fasteners
- Standard or Custom Radii

- Total Travel w/o Supports = 37.0 ft. ①
- Maximum Speed = 400 fpm
- Maximum Acceleration = 5.0 ft/sec<sup>2</sup>
- Maximum Cable/Hose O.D. = 2.28"
- PowerTrak Weight Unloaded = 8.42 lbs/ft. ②

## GENERAL LAYOUT

(Dimensions in Inches unless otherwise specified)

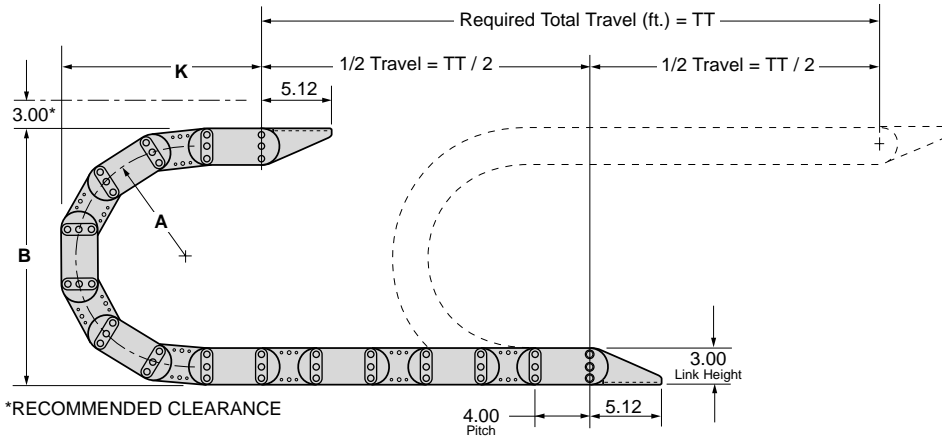

## MOUNTING BRACKETS

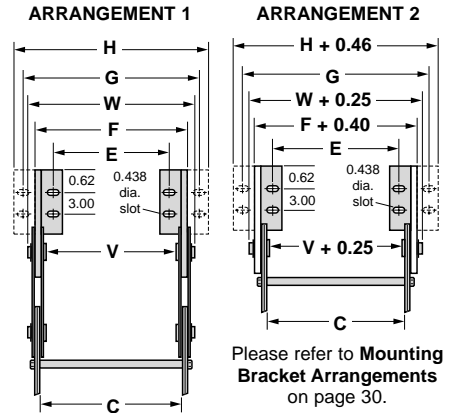

Please refer to Mounting Bracket Arrangements on page 30.

Radius A	Height B	Minimum K	Curve L ④
3.50	10.00	11.50	2.0 ft.
5.00	13.00	10.65	2.0 ft.
6.00	15.00	13.08	2.5 ft.
7.88	18.75	15.00	3.0 ft.
11.38	25.75	19.00	4.0 ft.
15.38	33.75	22.72	5.0 ft.

Carrier Width C	Feet Turned IN		Feet Turned OUT	
	Mtg. Location E ± .75	Brkt. O/A F ± .070	Mtg. Location G ± .75	Brkt. O/A H
4.00	2.56	4.42	6.38	7.68
6.00	4.56	6.42	8.38	9.68
8.00	6.56	8.42	10.38	11.68
10.00	8.56	10.42	12.38	13.68
12.00	10.56	12.42	14.38	15.68
14.00	12.56	14.42	16.38	17.68
16.00	14.56	16.42	18.38	19.68
FORMULA	C - 1.44	C + .42	C + 2.38	C + 3.68

Required Length (ft.)<sup>③</sup> =  $\frac{TT}{2} + L$

## NOTES REGARDING TRAK

- ① Based on standard travel with cable/hose package weight of 2.00 lbs/ft.
- ② Based on average carrier weight @ 8.00" width. For detailed information, please see "Weight Calculations".
- ③ Based on standard travel, i.e. two-way payout as pictured above.
- ④ L = minimum length in FEET required to form PowerTrak curve.

## CABLE/HOSE CARRIER OPTIONS (Dimensions in Inches)

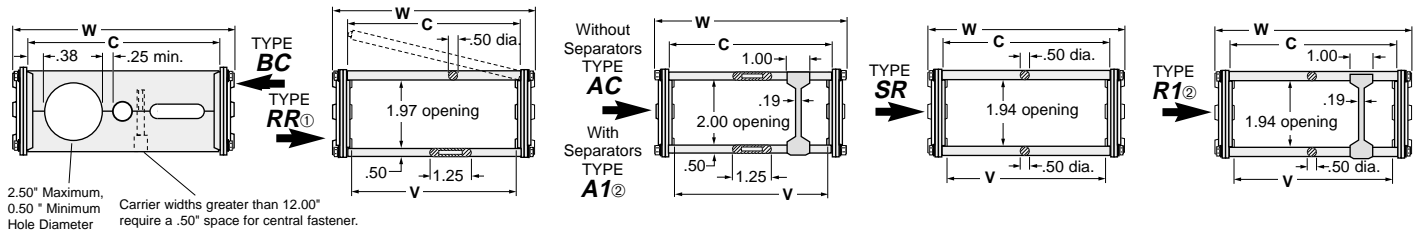

Carrier Width C	Usable Window Width V	Overall PowerTrak Width W
4.00	3.62	5.21
6.00	5.62	7.21
8.00	7.62	9.21
10.00	9.62	11.21
12.00	11.62	13.21
14.00	13.62	15.21
16.00	15.62	17.21
Formula	C - .38	C + 1.21

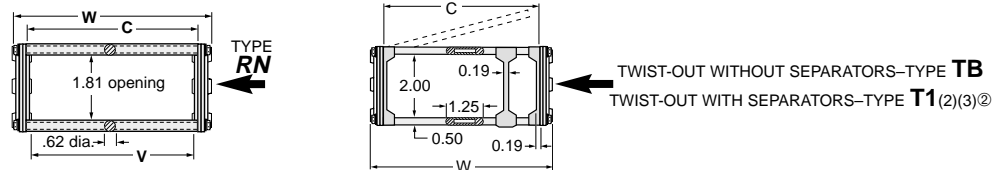

## NOTES REGARDING CARRIERS

- ① Carrier type RR limited to "C" dimension no greater than 10.00".
- ② Numeral "1" refers to number of vertical separators desired (2 = two separators, 3 = three separators, etc.). Number must be included in the model number when ordering.

- Standard Duty
- High Strength, Low Alloy Steel
- E-type Standard Duty Links
- Rugged One-piece Push-on Fasteners
- Standard or Custom Radii

- Total Travel w/o Supports = 43.0 ft. ①
- Maximum Speed = 500 fpm
- Maximum Acceleration = 5.0 ft/sec<sup>2</sup>
- Maximum Cable/Hose O.D. = 2.73"
- PowerTrak Weight Unloaded = 10.48 lbs/ft. ②

## GENERAL LAYOUT

(Dimensions in Inches unless otherwise specified)

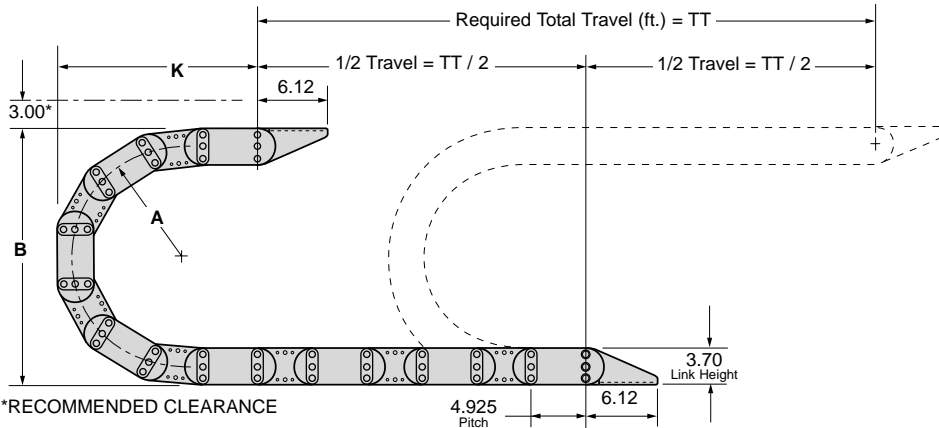

\*RECOMMENDED CLEARANCE

## MOUNTING BRACKETS

### ARRANGEMENT 1

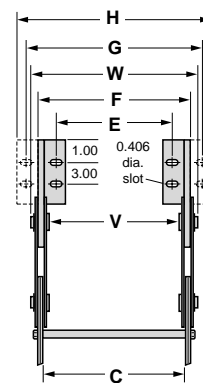

### ARRANGEMENT 2

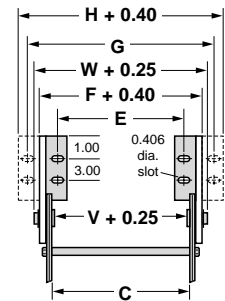

Please refer to **Mounting Bracket Arrangements** on page 30.

Radius A	Height B	Minimum K	Curve L ④
5.71	15.12	13.59	2.5 ft.
7.50	18.70	15.56	3.0 ft.
11.22	26.14	19.44	4.0 ft.
15.00	33.70	23.28	5.0 ft.
24.31	52.33	32.97	7.5 ft.

Carrier Width C	Feet Turned IN		Feet Turned OUT	
	Mtg. Location E ± .38	Brkt. O/A F ± .070	Mtg. Location G ± .38	Brkt. O/A H
4.00	2.25	4.42	6.62	8.00
6.00	4.25	6.42	8.62	10.00
8.00	6.25	8.42	10.62	12.00
10.00	8.25	10.42	12.62	14.00
12.00	10.25	12.42	14.62	16.00
14.00	12.25	14.42	16.62	18.00
16.00	14.25	16.42	18.62	20.00
FORMULA	C - 1.75	C + .42	C + 2.62	C + 4.00

$$\text{Required Length (ft.)}^{\textcircled{3}} = \frac{TT}{2} + L$$

## NOTES REGARDING TRAK

- ① Based on standard travel with cable/hose package weight of 2.00 lbs/ft.
- ② Based on average carrier weight @ 8.00" width. For detailed information, please see "Weight Calculations".
- ③ Based on standard travel, i.e. two-way payout as pictured above.
- ④ L = minimum length in FEET required to form PowerTrak curve.

## CABLE/HOSE CARRIER OPTIONS (Dimensions in Inches)

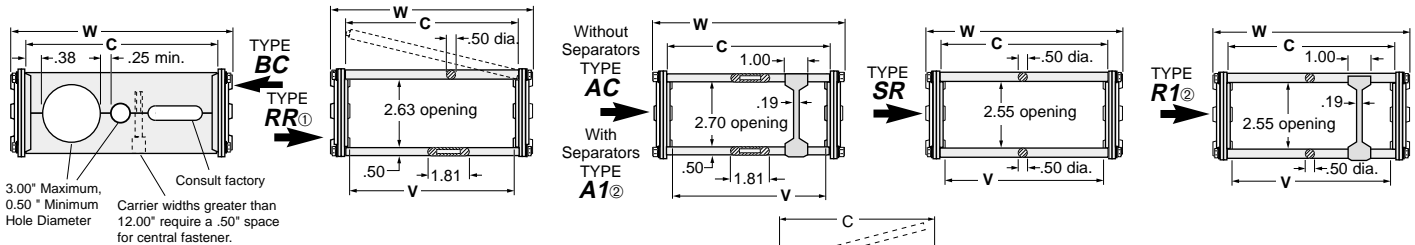

Carrier Width C	Usable Window Width V	Overall PowerTrak Width W
4.00	3.50	5.09
6.00	5.50	7.09
8.00	7.50	9.09
10.00	9.50	11.09
12.00	11.50	13.09
14.00	13.50	15.09
16.00	15.50	17.09
Formula	C - 0.50	C + 1.09

## NOTES REGARDING CARRIERS

- ① Carrier type RR limited to "C" dimension no greater than 10.00".
- ② Numeral "1" refers to number of vertical separators desired (2 = two separators, 3 = three separators, etc.). Number must be included in the model number when ordering.

- Standard Duty
- High Strength, Low Alloy Steel
- E-type Standard Duty Links
- Rugged One-piece Push-on Fasteners
- Standard or Custom Radii

- Total Travel w/o Supports = 46.0 ft. ①
- Maximum Speed = 500 fpm
- Maximum Acceleration = 5.0 ft/sec<sup>2</sup>
- Maximum Cable/Hose O.D. = 3.41"
- PowerTrak Weight Unloaded = 14.62 lbs/ft. ②

### GENERAL LAYOUT

(Dimensions in Inches unless otherwise specified)

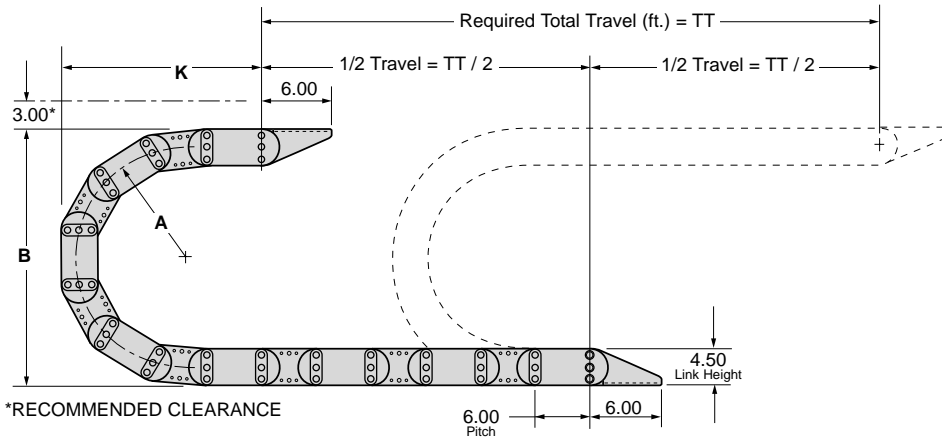

### MOUNTING BRACKETS

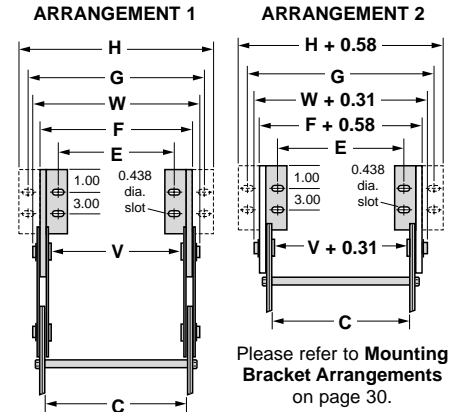

Please refer to Mounting Bracket Arrangements on page 30.

Radius A	Height B	Minimum K	Curve L ④
5.75	16.00	16.97	3.0 ft.
7.50	19.50	15.97	3.0 ft.
11.25	27.00	19.83	4.0 ft.
15.00	34.50	23.69	5.0 ft.
24.25	53.00	33.41	7.5 ft.

Carrier Width C	Feet Turned IN		Feet Turned OUT	
	Mtg. Location E ± .75	Brkt. O/A F ± .070	Mtg. Location G ± .75	Brkt. O/A H
4.00	2.50	4.54	6.38	7.75
6.00	4.50	6.54	8.38	9.75
8.00	6.50	8.54	10.38	11.75
10.00	8.50	10.54	12.38	13.75
12.00	10.50	12.54	14.38	15.75
14.00	12.50	14.54	16.38	17.75
16.00	14.50	16.54	18.38	19.75
FORMULA	C - 1.50	C + .54	C + 2.38	C + 3.75

Required Length (ft.) ③ =  $\frac{TT}{2} + L$

### NOTES REGARDING TRAK

- ① Based on standard travel with cable/hose package weight of 2.00 lbs/ft.
- ② Based on average carrier weight @ 8.00" width. For detailed information, please see "Weight Calculations".
- ③ Based on standard travel, i.e. two-way payout as pictured above.
- ④ L = minimum length in FEET required to form PowerTrak curve.

### CABLE/HOSE CARRIER OPTIONS (Dimensions in Inches)

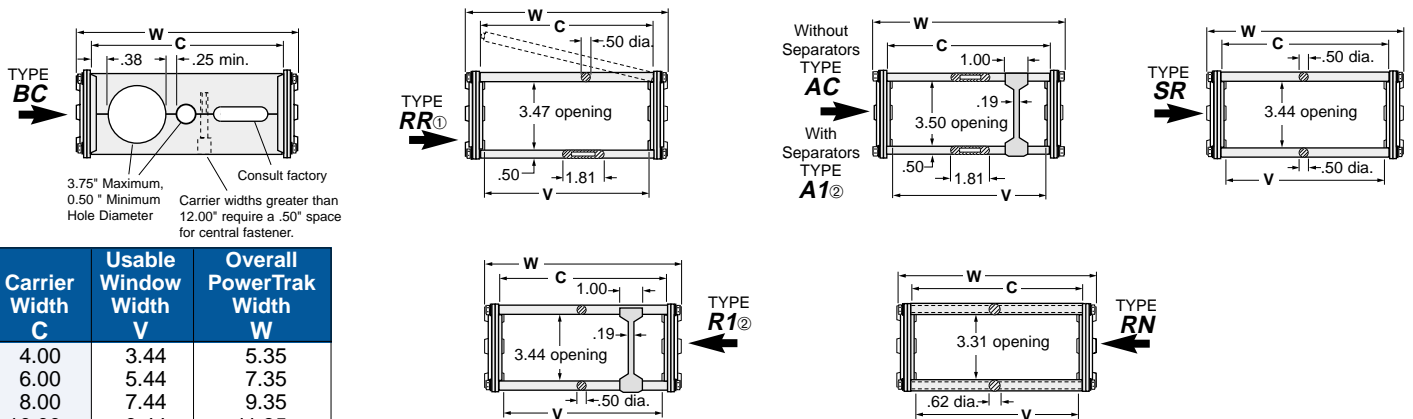

Carrier Width C	Usable Window Width V	Overall PowerTrak Width W
4.00	3.44	5.35
6.00	5.44	7.35
8.00	7.44	9.35
10.00	9.44	11.35
12.00	11.44	13.35
14.00	13.44	15.35
16.00	15.44	17.35
Formula	C - .56	C + 1.35

### NOTES REGARDING CARRIERS

- ① Carrier type RR limited to "C" dimension no greater than 10.00".
- ② Numeral "1" refers to number of vertical separators desired (2 = two separators, 3 = three separators, etc.). Number must be included in the model number when ordering.

- Heavy Duty or Mill Duty
- High Strength, Low Alloy Steel
- E-type or EF-Type (flanged) Links
- Retaining Ring or Bolted Construction<sup>⑤</sup>
- Standard or Custom Radii
- Total Travel w/o Supports = 48.0 ft. <sup>①</sup>
- Maximum Speed = 500 fpm
- Maximum Acceleration = 5.0 ft/sec<sup>2</sup>
- Maximum Cable/Hose O.D. = 4.10"
- PowerTrak Weight Unloaded = 22.10 lbs/ft. <sup>②</sup>

### GENERAL LAYOUT

(Dimensions in Inches unless otherwise specified)

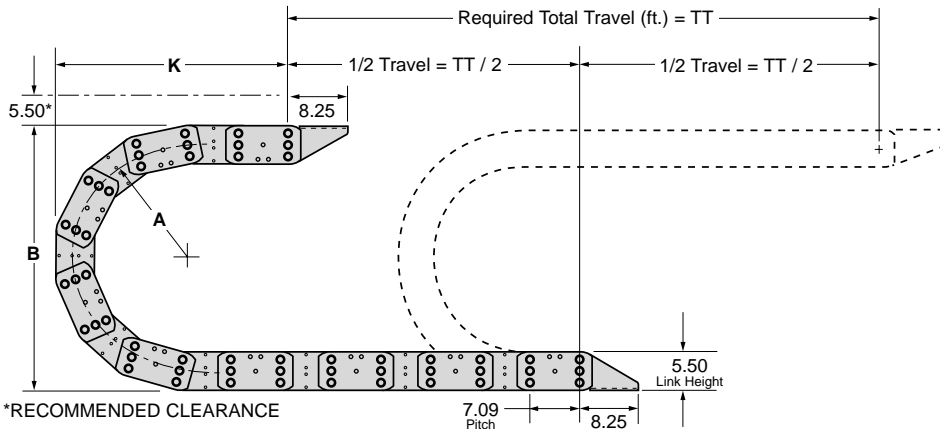

\*RECOMMENDED CLEARANCE

### MOUNTING BRACKETS

#### ARRANGEMENT 1

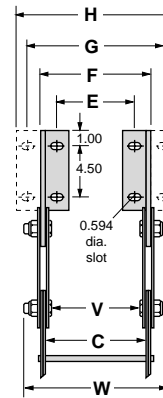

Only mounting bracket arrangement 1 can be used with types PT55E & PT55EF. Please refer to Mounting Bracket Arrangements on page 30.

Radius A	Height B	Minimum K	Curve L <sup>④</sup>
11.22	27.94	26.35	5.0 ft.
15.00	35.50	30.19	6.0 ft.
18.69	42.88	34.08	7.0 ft.
24.31	54.12	39.87	8.5 ft.
30.00	65.50	45.63	10.0 ft.
36.00	77.50	51.20	11.5 ft.

Required Length (ft.) <sup>③</sup> =  $\frac{TT}{2} + L$

PowerTrak length will be rounded to "odd" number of links.

#### NOTES REGARDING TRAK

- ① Based on standard travel with cable/hose package weight of 2.00 lbs/ft.
- ② Based on average carrier weight @ 14.00" width. For detailed information, please see "Weight Calculations".
- ③ Based on standard travel, i.e. two-way payout as pictured above.
- ④ L = minimum length in FEET required to form PowerTrak curve.
- ⑤ Retaining Ring construction standard on Heavy Duty (E-type) PowerTrak. Bolted construction standard on Mill Duty (EF-type) PowerTrak.

Carrier Width C	Feet Turned IN		Feet Turned OUT	
	Mtg. Location E ± .44	Brkt. O/A F ± .070	Mtg. Location G ± .44	Brkt. O/A H
6.00	3.72	6.54	8.82	10.75
8.00	5.72	8.54	10.82	12.75
10.00	7.72	10.54	12.82	14.75
12.00	9.72	12.54	14.82	16.75
14.00	11.72	14.54	16.82	18.75
16.00	13.72	16.54	18.82	20.75
18.00	15.72	18.54	20.82	22.75
20.00	17.72	20.54	22.82	24.75
22.00	19.72	22.54	24.82	26.75
24.00	21.72	24.54	26.82	28.75
FORMULA	C - 2.28	C + .54	C + 2.82	C + 4.75

### CABLE/HOSE CARRIER OPTIONS – (Dimensions in Inches)

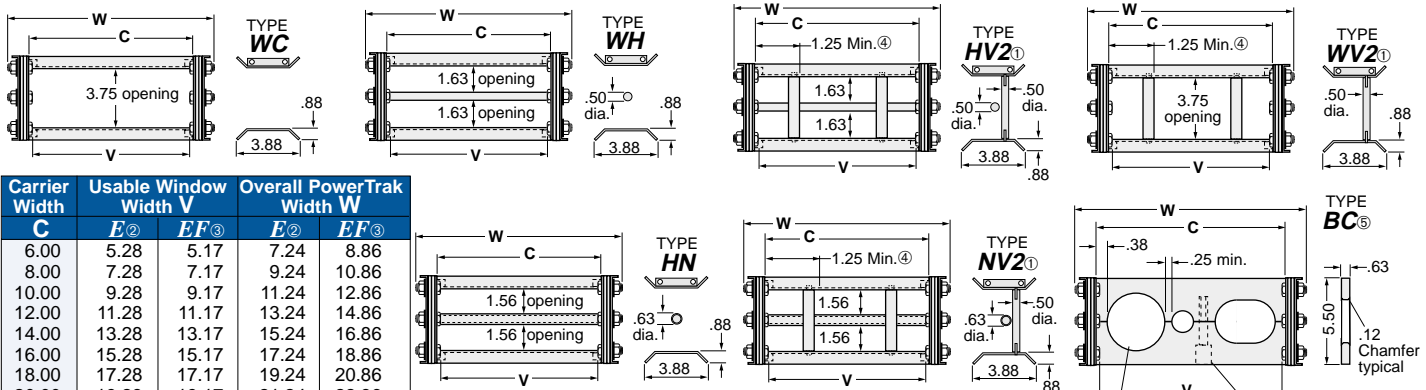

Carrier Width C	Usable Window Width V		Overall PowerTrak Width W	
	E <sup>②</sup>	EF <sup>③</sup>	E <sup>②</sup>	EF <sup>③</sup>
6.00	5.28	5.17	7.24	8.86
8.00	7.28	7.17	9.24	10.86
10.00	9.28	9.17	11.24	12.86
12.00	11.28	11.17	13.24	14.86
14.00	13.28	13.17	15.24	16.86
16.00	15.28	15.17	17.24	18.86
18.00	17.28	17.17	19.24	20.86
20.00	19.28	19.17	21.24	22.86
22.00	21.28	21.17	23.24	24.86
24.00	23.28	23.17	25.24	26.86
Formula	C - 0.72	C - 0.83	C + 1.24	C + 2.86

Mill Duty (EF-Type) with standard bolted construction shown. Heavy Duty (E-Type) has pins with retaining ring standard. Dimensions vary slightly. See page 4 and notes below.

4.50" Maximum, 0.50" Minimum Hole Diameter  
Carrier widths greater than 12.00" require a .50" space for central fastener.

#### NOTES REGARDING CARRIERS

- ① Numeral "2" refers to number of vertical separators desired (2 = two separators, 3 = three separators, etc.). Number must be included in the model number when ordering.
- ② Bolted option for PT55E (PT55EB) alters dimensions slightly: V = C - 0.83 and W = C + 2.86.
- ③ Retaining Ring option for PT55EF (PT55EFP) alters dimensions slightly: V = C - 0.72 and W = C + 1.86.
- ④ Separators adjustable in 1.00" increments.
- ⑤ Custom milled carriers. Maximum hole diameter = 4.5". Minimum hole diameter = 0.50". Consult factory for slotted openings.



- Heavy Duty or Mill Duty
- High Strength, Low Alloy Steel
- E-type or EF-Type (flanged) Links
- Retaining Ring or Bolted Construction<sup>⑤</sup>
- Standard or Custom Radii
- Total Travel w/o Supports = 54.0 ft. <sup>①</sup>
- Maximum Speed = 500 fpm
- Maximum Acceleration = 5.0 ft/sec<sup>2</sup>
- Maximum Cable/Hose O.D. = 4.55"
- PowerTrak Weight Unloaded = 25.89 lbs/ft. <sup>②</sup>

### GENERAL LAYOUT

(Dimensions in Inches unless otherwise specified)

### MOUNTING BRACKETS

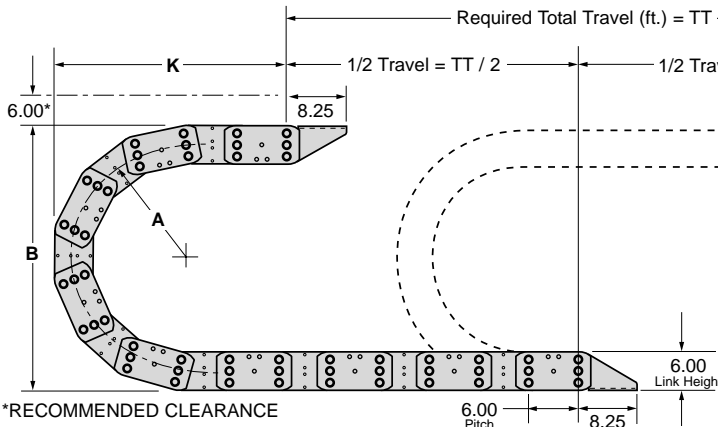

#### ARRANGEMENT 1

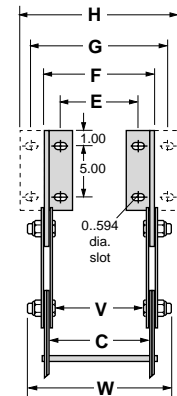

Only mounting bracket arrangement 1 can be used with types PT60E & PT60EF. Please refer to **Mounting Bracket Arrangements** on page 30.

\*RECOMMENDED CLEARANCE

Radius A	Height B	Minimum K	Curve L <sup>④</sup>
11.00	28.00	23.72	4.5 ft.
14.81	35.63	27.55	5.5 ft.
20.50	47.00	33.30	7.0 ft.
24.12	54.25	37.22	8.0 ft.
29.50	65.00	43.16	9.5 ft.

Carrier Width C	Feet Turned IN		Feet Turned OUT	
	Mtg. Location E ± .44	Brkt. O/A F ± .070	Mtg. Location G ± .44	Brkt. O/A H
6.00	3.72	6.54	8.82	10.75
8.00	5.72	8.54	10.82	12.75
10.00	7.72	10.54	12.82	14.75
12.00	9.72	12.54	14.82	16.75
14.00	11.72	14.54	16.82	18.75
16.00	13.72	16.54	18.82	20.75
18.00	15.72	18.54	20.82	22.75
20.00	17.72	20.54	22.82	24.75
22.00	19.72	22.54	24.82	26.75
24.00	21.72	24.54	26.82	28.75
FORMULA	C - 2.28	C + .54	C + 2.82	C + 4.75

$$\text{Required Length (ft.)}^{\text{③}} = \frac{\pi}{2} L + L$$

PowerTrak length will be rounded to "odd" number of links.

### NOTES REGARDING TRAK

- ① Based on standard travel with cable/hose package weight of 2.00 lbs/ft.
- ② Based on average carrier weight @ 14.00" width. For detailed information, please see "Weight Calculations".
- ③ Based on standard travel, i.e. two-way payout as pictured above.
- ④ L = minimum length in FEET required to form PowerTrak curve.
- ⑤ Retaining Ring construction standard on Heavy Duty (E-type) PowerTrak. Bolted construction standard on Mill Duty (EF-type) PowerTrak.

### CABLE/HOSE CARRIER OPTIONS – (Dimensions in Inches)

Carrier Width C	Usable Window Width V	Overall PowerTrak Width W
6.00	5.28	5.17
8.00	7.28	7.17
10.00	9.28	9.17
12.00	11.28	11.17
14.00	13.28	13.17
16.00	15.28	15.17
18.00	17.28	17.17
20.00	19.28	19.17
22.00	21.28	21.17
24.00	23.28	23.17
Formula	C - 0.72	C + 2.86

**Mill Duty (EF-Type) with standard bolted construction shown. Heavy Duty (E-Type) has pins with retaining ring standard. Dimensions vary slightly. See page 4 and notes below.**

5.00" Maximum, 0.50 Minimum Hole Diameter  
Carrier widths greater than 12.00" require a .50" space for central fastener.

### NOTES REGARDING CARRIERS

- ① Numeral "2" refers to number of vertical separators desired (2 = two separators, 3 = three separators, etc.). Number must be included in the model number when ordering.
- ② Bolted option for PT60E (PT60EB) alters dimensions slightly: V = C - 0.83 and W = C + 2.86.
- ③ Retaining Ring option for PT60EF (PT60EFP) alters dimensions slightly: V = C - 0.72 and W = C + 1.86.
- ④ Separators adjustable in 1.00" increments.
- ⑤ Custom milled carriers. Maximum hole diameter = 5.00". Minimum hole diameter = 0.50". Consult factory for slotted openings.

- Heavy Duty or Mill Duty
- High Strength, Low Alloy Steel
- E-type or EF-Type (flanged) Links
- Retaining Ring or Bolted Construction®
- Standard or Custom Radii
- Total Travel w/o Supports = 61.0 ft. ①
- Maximum Speed = 500 fpm
- Maximum Acceleration = 5.0 ft/sec<sup>2</sup>
- Maximum Cable/Hose O.D. = 5.45"
- PowerTrak Weight Unloaded = 33.14 lbs/ft. ②

## GENERAL LAYOUT

(Dimensions in Inches unless otherwise specified)

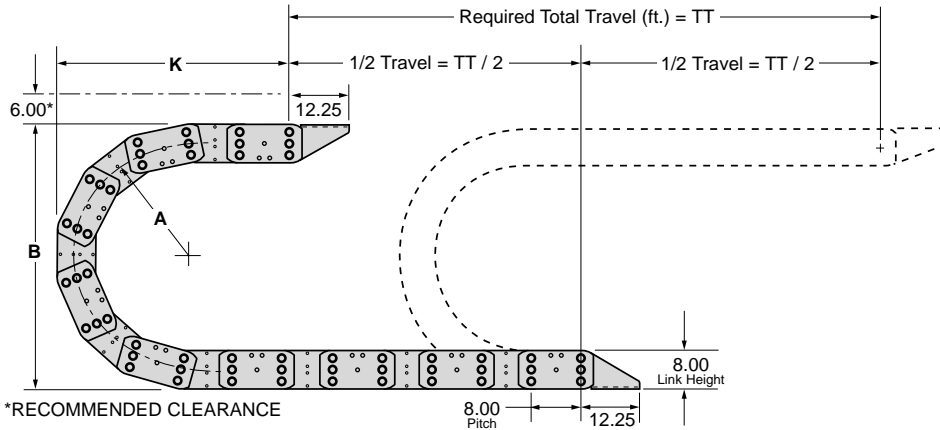

## MOUNTING BRACKETS

### ARRANGEMENT 1

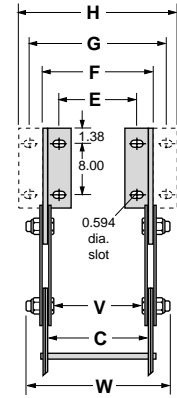

Only mounting bracket arrangement 1 can be used with types PT80E & PT80EF. Please refer to **Mounting Bracket Arrangements** on page 30.

Radius A	Height B	Minimum K	Curve L ④
10.50	29.00	28.00	5.0 ft.
12.50	33.00	29.87	5.5 ft.
19.50	47.00	37.87	7.5 ft.
23.12	54.25	38.80	8.0 ft.

Carrier Width C	Feet Turned IN		Feet Turned OUT	
	Mtg. Location E ± .69	Brkt. O/A F ± .070	Mtg. Location G ± .69	Brkt. O/A H
8.00	5.72	8.54	10.82	12.75
10.00	7.72	10.54	12.82	14.75
12.00	9.72	12.54	14.82	16.75
14.00	11.72	14.54	16.82	18.75
16.00	13.72	16.54	18.82	20.75
18.00	15.72	18.54	20.82	22.75
20.00	17.72	20.54	22.82	24.75
22.00	19.72	22.54	24.82	26.75
24.00	21.72	24.54	26.82	28.75
FORMULA	C - 2.28	C + .54	C + 2.82	C + 4.75

$$\text{Required Length (ft.)}^{\textcircled{3}} = \frac{\text{TT}}{2} + \text{L}$$

PowerTrak length will be rounded to "odd" number of links.

## NOTES REGARDING TRAK

- ① Based on standard travel with cable/hose package weight of 2.00 lbs/ft.
- ② Based on average carrier weight @ 14.00" width. For detailed information, please see "Weight Calculations".
- ③ Based on standard travel, i.e. two-way payout as pictured above.
- ④ L = minimum length in FEET required to form PowerTrak curve.
- ⑤ Retaining Ring construction standard on Heavy Duty (E-type) PowerTrak. Bolted construction standard on Mill Duty (EF-type) PowerTrak.

## CABLE/HOSE CARRIER OPTIONS – (Dimensions in Inches)

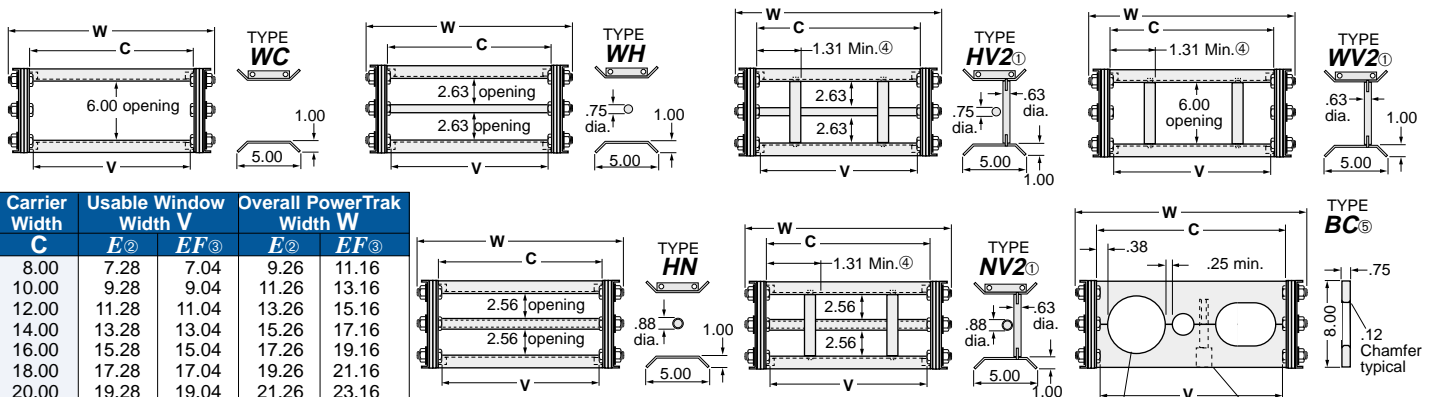

Carrier Width C	Usable Window Width V		Overall PowerTrak Width W	
	E②	EF③	E②	EF③
8.00	7.28	7.04	9.26	11.16
10.00	9.28	9.04	11.26	13.16
12.00	11.28	11.04	13.26	15.16
14.00	13.28	13.04	15.26	17.16
16.00	15.28	15.04	17.26	19.16
18.00	17.28	17.04	19.26	21.16
20.00	19.28	19.04	21.26	23.16
20.00	21.28	21.04	23.26	25.16
24.00	23.28	23.04	25.26	27.16
Formula	C - 0.72	C - 0.96	C + 1.26	C + 3.16

Mill Duty (EF-Type) with standard bolted construction shown. Heavy Duty (E-Type) has pins with retaining ring standard. Dimensions vary slightly. See page 4 and notes below.

6.50" Maximum, 0.50" Minimum Hole Diameter  
Carrier widths greater than 12.00" require a .50" space for central fastener.

## NOTES REGARDING CARRIERS

- ① Numeral "2" refers to number of vertical separators desired (2 = two separators, 3 = three separators, etc.). Number must be included in the model number when ordering.
- ② Bolted option for PT80E (PT80EB) alters dimensions slightly: V = C - 0.96 and W = C + 3.16.
- ③ Retaining Ring option for PT80EF (PT80EFP) alters dimensions slightly: V = C - 0.72 and W = C + 2.24.
- ④ Separators adjustable in 1.00" increments.
- ⑤ Custom milled carriers. Maximum hole diameter = 6.50". Minimum hole diameter = 0.50". Consult factory for slotted openings.

- Heavy Duty or Mill Duty
- High Strength, Low Alloy Steel
- E-type or EF-Type (flanged) Links
- Retaining Ring or Bolted Construction®
- Standard or Custom Radii

- Total Travel w/o Supports = 73.0 ft. ①
- Maximum Speed = 500 fpm
- Maximum Acceleration = 5.0 ft/sec<sup>2</sup>
- Maximum Cable/Hose O.D. = 7.30"
- PowerTrak Weight Unloaded = 38.52 lbs/ft. ②

### GENERAL LAYOUT

(Dimensions in Inches unless otherwise specified)

### MOUNTING BRACKETS

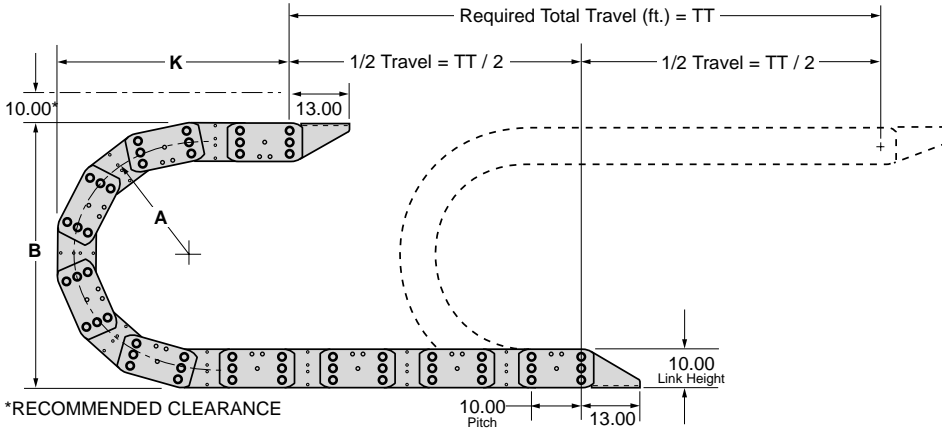

#### ARRANGEMENT 1

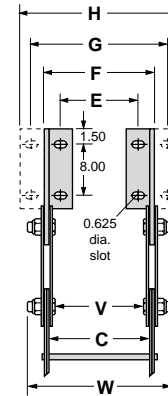

Only mounting bracket arrangement 1 can be used with types PT100E & PT100EF. Please refer to Mounting Bracket Arrangements on page 30.

Radius A	Height B	Minimum K	Curve L ④
19.00	48.00	39.15	7.5 ft.
25.00	60.00	44.73	9.0 ft.

Carrier Width C	Feet Turned IN		Feet Turned OUT	
	Mtg. Location E ± .69	Brkt. O/A F ± .070	Mtg. Location G ± .69	Brkt. O/A H
10.00	7.72	10.54	12.82	14.75
12.00	9.72	12.54	14.82	16.75
14.00	11.72	14.54	16.82	18.75
16.00	13.72	16.54	18.82	20.75
18.00	15.72	18.54	20.82	22.75
20.00	17.72	20.54	22.82	24.75
22.00	19.72	22.54	24.82	26.75
24.00	21.72	24.54	26.82	28.75
FORMULA	C - 2.28	C + .54	C + 2.82	C + 4.75

Required Length (ft.) ③ =  $\frac{TT}{2} + L$

PowerTrak length will be rounded to "odd" number of links.

### NOTES REGARDING TRAK

- ① Based on standard travel with cable/hose package weight of 2.00 lbs/ft.
- ② Based on average carrier weight @ 14.00" width. For detailed information, please see "Weight Calculations".
- ③ Based on standard travel, i.e. two-way payout as pictured above.
- ④ L = minimum length in FEET required to form PowerTrak curve.
- ⑤ Retaining Ring construction standard on Heavy Duty (E-type) PowerTrak. Bolted construction standard on Mill Duty (EF-type) PowerTrak.

### CABLE/HOSE CARRIER OPTIONS – (Dimensions in Inches)

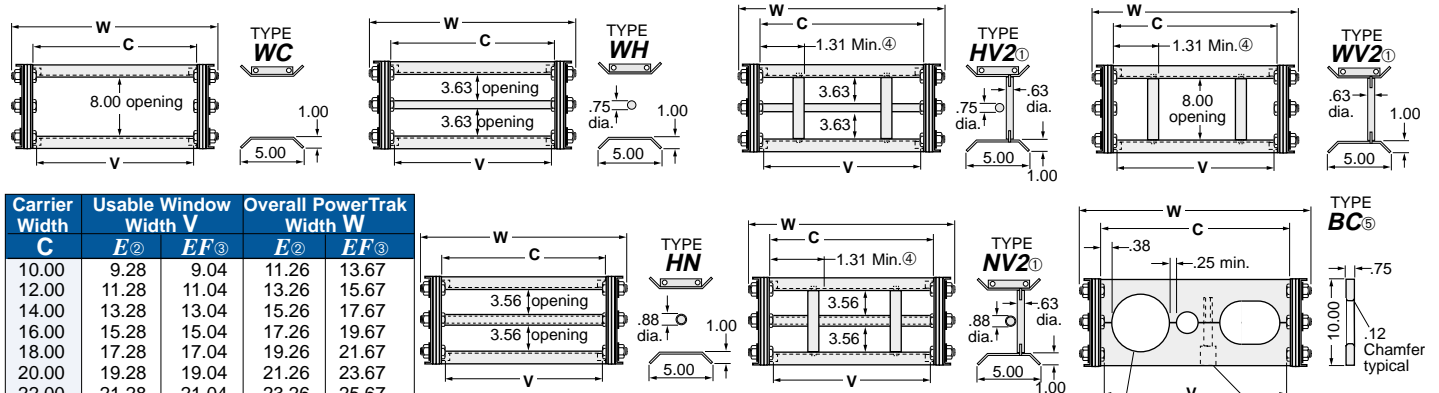

Carrier Width C	Usable Window Width V		Overall PowerTrak Width W	
	E2	EF3	E2	EF3
10.00	9.28	9.04	11.26	13.67
12.00	11.28	11.04	13.26	15.67
14.00	13.28	13.04	15.26	17.67
16.00	15.28	15.04	17.26	19.67
18.00	17.28	17.04	19.26	21.67
20.00	19.28	19.04	21.26	23.67
22.00	21.28	21.04	23.26	25.67
24.00	23.28	23.04	25.26	27.67
Formula	C - 0.72	C - 0.96	C + 1.26	C + 3.67

Mill Duty (EF-Type) with standard bolted construction shown. Heavy Duty (E-Type) has pins with retaining ring standard. Dimensions vary slightly. See page 4 and notes below.

8.50" Maximum, 0.50" Minimum Hole Diameter. Carrier widths greater than 12.00" require a .50" space for central fastener.

### NOTES REGARDING CARRIERS

- ① Numeral "2" refers to number of vertical separators desired (2 = two separators, 3 = three separators, etc.). Number must be included in the model number when ordering.
- ② Bolted option for PT100E (PT100EB) alters dimensions slightly: V = C - 0.96 and W = C + 3.67.
- ③ Retaining Ring option for PT100EF (PT100EFP) alters dimensions slightly: V = C - 0.72 and W = C + 2.54.
- ④ Separators adjustable in 1.00" increments.
- ⑤ Custom milled carriers. Maximum hole diameter = 8.50". Minimum hole diameter = 0.50". Consult factory for slotted openings.

# Carriage Systems

## For LONG TRAVELS – HIGH SPEEDS

Carriage Systems support PowerTrak throughout the entire travel length and allow longer travels and higher speeds than PowerTrak supported by rollers. Three types of systems cover a broad range of requirements.

These pages provide information to help you specify a system. Please contact the factory for additional details or a recommendation.

**STANDARD TRAVEL**

**OPPOSED TRAVEL**

Carriage Systems may be used on either Standard Travel or Opposed Travel PowerTrak systems. Opposed Travel, which utilizes TWO PowerTraks, allows for separation of cables and hoses and may reduce overall system width. See **Applying type "E" PowerTrak**, page 5.

## System Specifications

SYSTEM TYPE	MAXIMUM TRAVEL	MAXIMUM SPEED	MAXIMUM ACCELERATION	POWERTRAK SIZE(S) AVAILABLE
222	500 FT.	400 FPM	5 FPS <sup>2</sup>	PT35E (5.22" radius only)
224	500 FT.	600 FPM	5 FPS <sup>2</sup>	PT35E, PT45E <sup>①</sup>
225	1000 FT. <sup>②</sup>	1000 FPM	10 FPS <sup>2</sup>	PT35E, PT45E <sup>①</sup>

① Carriage systems for other PowerTrak sizes are available. Please consult factory.

② Longer travels are possible. Please consult factory.

## 222 Carriage System

DRAWING BELOW SHOWS STANDARD TRAVEL.  
Dimensions in inches unless otherwise noted.

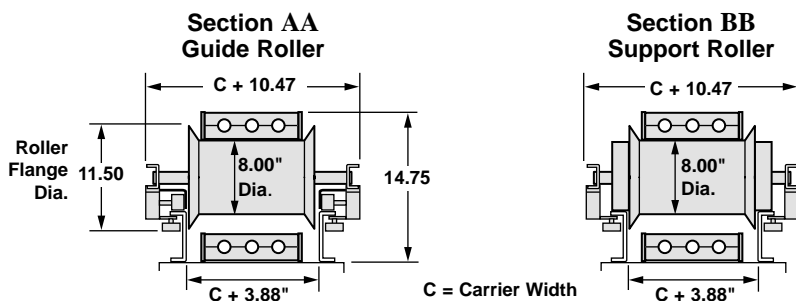
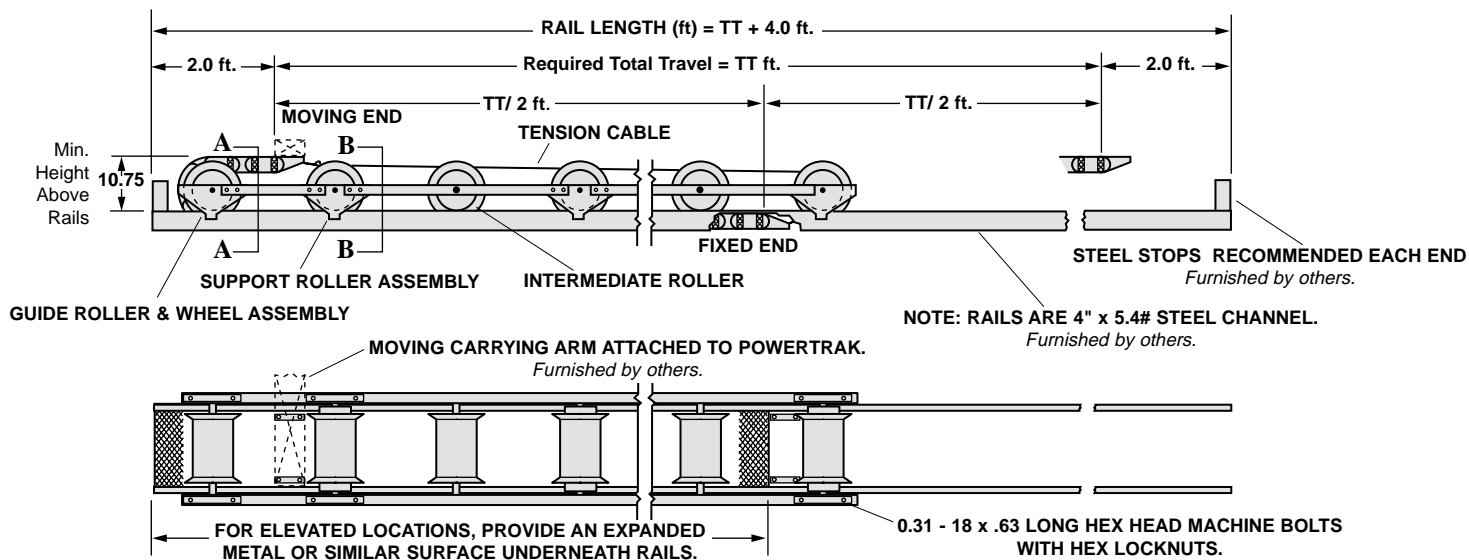

**Application Note**

Type 222 Carriage is available for use with PT35E PowerTrak with a radius of 5.22" only. Carriage length will be adjusted to suit PowerTrak length. Additional PowerTrak length is required when using carriage, as follows:

**STANDARD TRAVEL**  
PowerTrak Length = (TT / 2) + 3.5 ft.

**OPPOSED TRAVEL**  
PowerTrak Length = (TT / 2) + 2.5 ft.



# 224 Carriage System

DRAWING BELOW SHOWS STANDARD TRAVEL

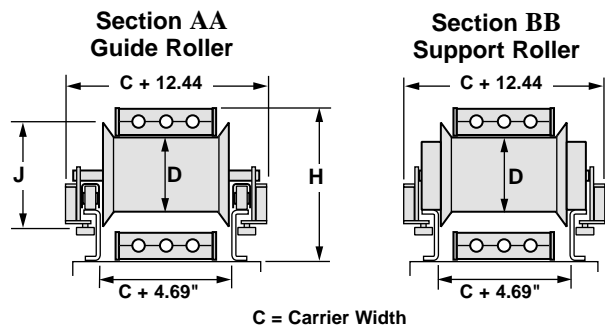
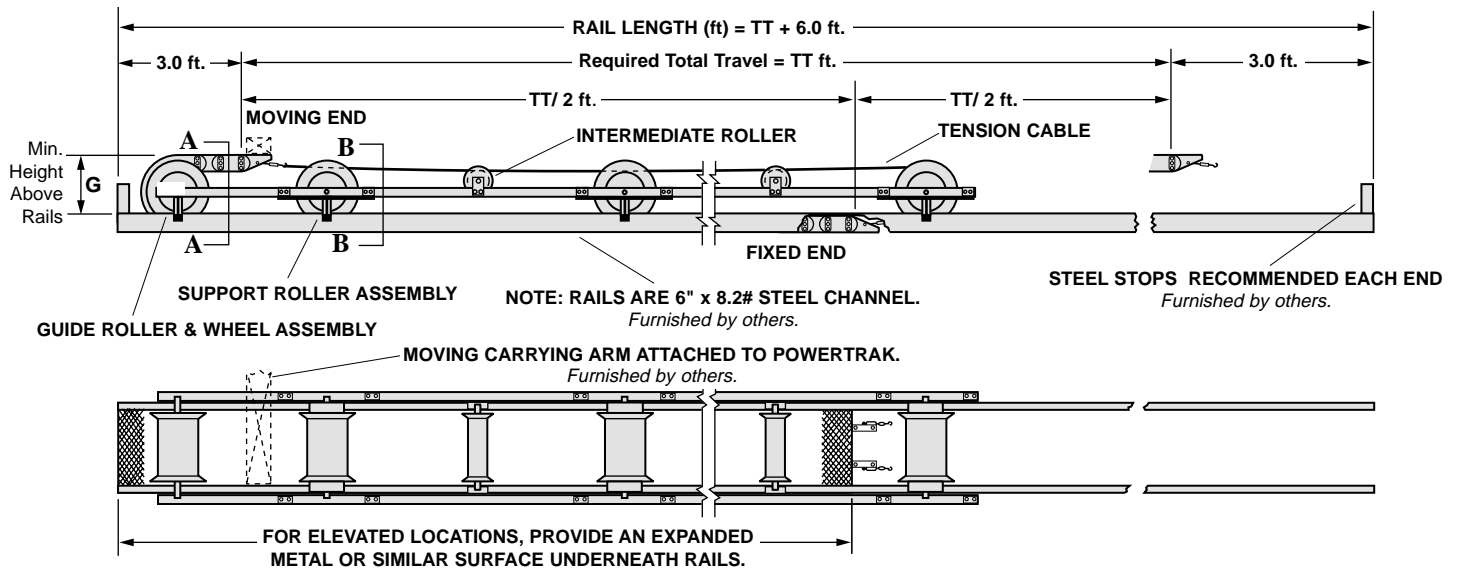

DIMENSIONS IN INCHES

POWERTRAK SIZE & RADIUS	DRUM DIA. D	FLANGE DIA. J	CARRIAGE HEIGHT H <sup>①</sup>	ABOVE RAILS G <sup>①</sup>	STANDARD CURVE L	OPPOSED CURVE L
PT35E-7.5	13.00	17.72	21.69	15.81	5.5 ft.	4.5 ft.
PT45E-7.5	13.00	17.72	22.72	16.88	5.5 ft.	4.5 ft.
PT35E-11.12	20.00	24.72	28.69	22.81	6.5 ft.	5.5 ft.
PT45E-11.2	20.00	24.72	29.72	23.88	6.5 ft.	5.5 ft.

①Minimum Clearance

PowerTrak Length = (TT / 2) + L

# 225 Carriage System

DRAWING BELOW SHOWS STANDARD TRAVEL

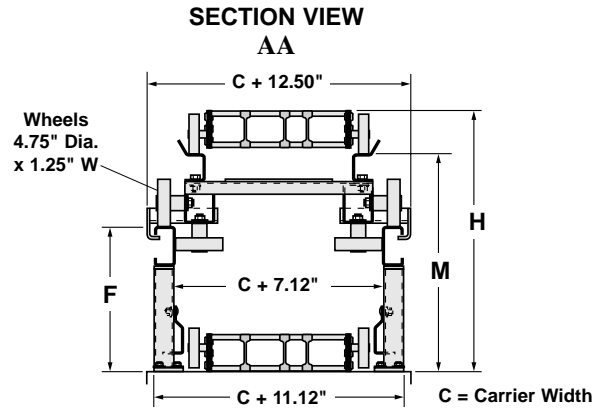
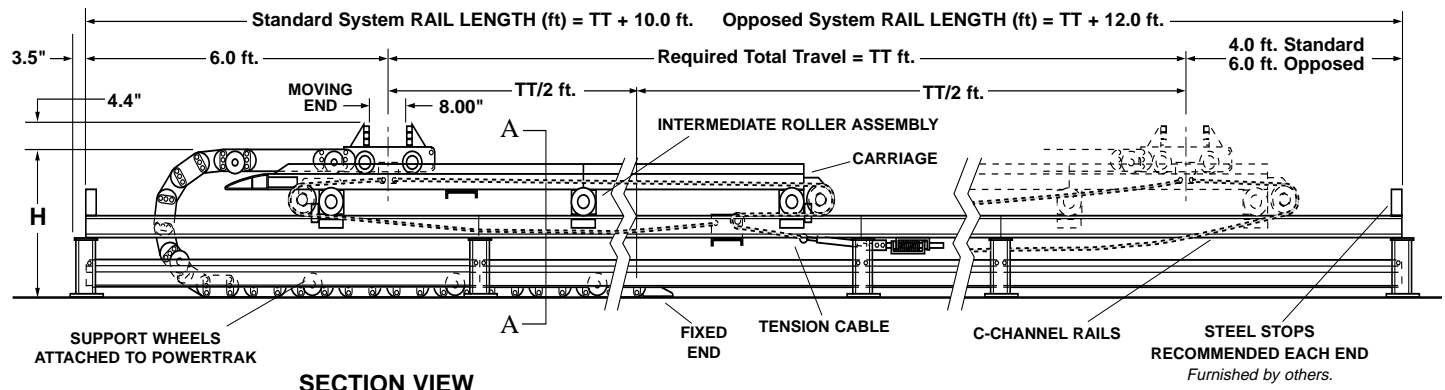

DIMENSIONS IN INCHES

POWERTRAK SIZE & RADIUS	F	CARRIAGE HEIGHT H <sup>①</sup>	M	STANDARD CURVE L	OPPOSED CURVE L
PT35E-7.5	8.76	19.35	16.17	7.5 ft.	5.0 ft.
PT45E-7.5	9.79	21.40	17.05	7.5 ft.	5.0 ft.
PT35E-11.12	15.76	26.35	23.17	8.5 ft.	6.0 ft.
PT45E-11.2	16.78	28.40	24.04	8.5 ft.	6.0 ft.

①Minimum Clearance

PowerTrak Length = (TT / 2) + L



PT-8

# Optional Accessories

## Roller Supports

Roller supports are mounted in a stationary position to increase the total travel capability of PowerTrak. For example, a given PowerTrak size may not handle the total weight of your cables and hoses when self-supported. Adding one or two supports may solve the problem.

See additional information under “Applying type “E” PowerTrak” in the front of this catalog. Roller supports are not recommended for use with sizes 25E and 28E.

PART NUMBER	CARRIER WIDTH C	A	D	E
090165	4.00	5.63	12.63	11.13
090166	6.00	7.63	14.63	13.13
090167	8.00	9.63	16.63	15.13
090168	10.00	11.63	18.63	17.13
090169	12.00	13.63	20.63	19.13
090170	14.00	15.63	22.63	21.13
090171	16.00	17.63	24.63	23.13
090172	18.00	19.63	26.63	25.13

\* Stand height may be calculated using the formula:

$$B = \text{PowerTrak Height} - \text{see "Dimensional Data" for "B" dimension of different Types and radii.}$$

$B = \text{PowerTrak Height} - \text{see "Dimensional Data" for "B" dimension of different Types and radii.}$

Link Height may be found in “Dimensional Data” as well.

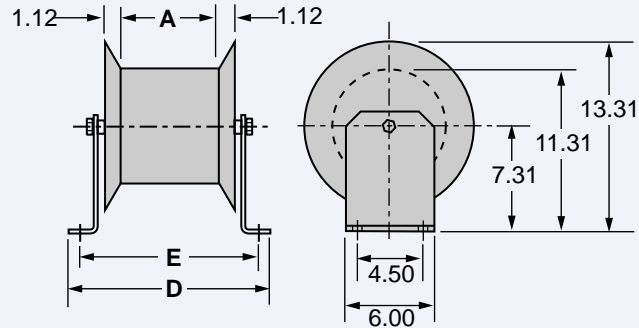
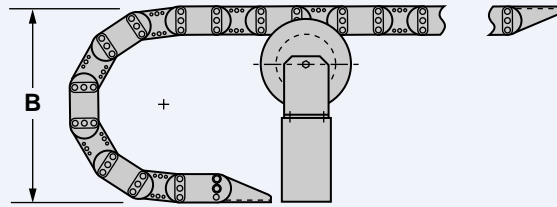

Roller Support shown here for sizes 35E - 48E only. For sizes 55E - 100E, please consult the factory.

## Sliding Mounting Brackets

Sliding mounting brackets assemblies are recommended when PowerTrak is required to handle medium and high pressure hoses. Normally attached to the movable end of the PowerTrak, Sliding Mounting Brackets absorb any shrinkage or expansion of hoses caused by hydraulic surge. Refer to hose manufacturers data for specific information.

PART NO.	FITS MODELS	A	B	C	D	E	F	G
PL20-10	25E-48E	12.50	7.50	1.50	2.50	1.25	4.50	5.00
014875	55E-100E	16.00	12.00	2.00	2.75	1.38	4.00	4.87

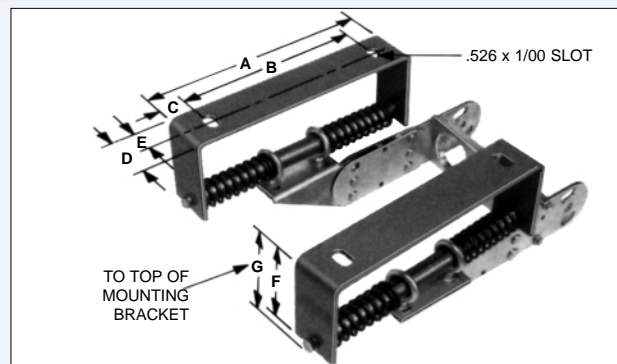

## Chip Covers

Stainless steel chip covers on both sides of the PowerTrak protect cables and hoses against hot chips and mechanical damage.

For use in the standard travel configuration only. Not for use with roller supports or for long travels. Not available for sizes 55E-100E. Please consult factory for recommendations.

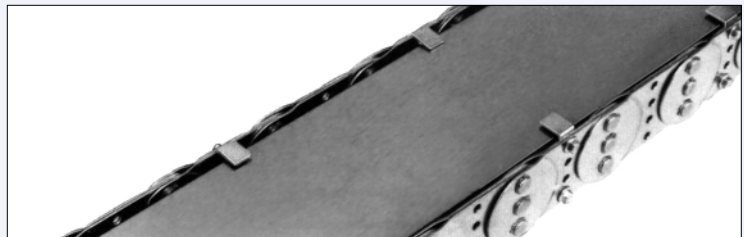

# Cable/hose Anchor Clamps

- Affixes hoses or cables at ends of trak to prevent undue wear or stress.\*
- Six sizes, for hose or cable 0.38" to 2.18" O.D.
- Rugged zinc plated steel for long life.
- Heavy duty steel mounting bracket.
- All clamps fit one mounting bracket. Simply attach proper size clamp when changing cable.

\* Clamps not recommended for fixed end on long trak runs in guide tray. Use bar clamp in this application. Consult factory for details.

CLIP MODEL CHART-TABLE A

CABLE / HOSE O.D. in. (mm)	WIDTH W in. (mm)	HEIGHT H in. (mm)	CLIP PART NUMBER
0.38-0.62 (10-16)	1.1 (28)	2.1 (54)	04095101
0.63-0.88 (16-22)	1.4 (36)	2.3 (59)	04095102
0.89-1.12 (22-28)	1.6 (41)	2.4 (62)	04095103
1.13-1.38 (28-35)	2.1 (53)	2.7 (70)	04095104
1.39-1.75 (35-44)	2.3 (58)	3.0 (77)	04095105
1.76-2.18 (44-55)	2.7 (69)	3.5 (90)	04095106

MOUNTING BRACKET  
MODEL CHART-TABLE B

CARRIER WIDTH in. (mm)	MOUNTING BRACKET PART NO.
4.00 (102)	03946501
6.00 (152)	03946502
8.00 (203)	03946503
10.00 (254)	03946504
12.00 (305)	03946505
14.00 (356)	03946506
16.00 (406)	03946507
18.00 (457)	03946508

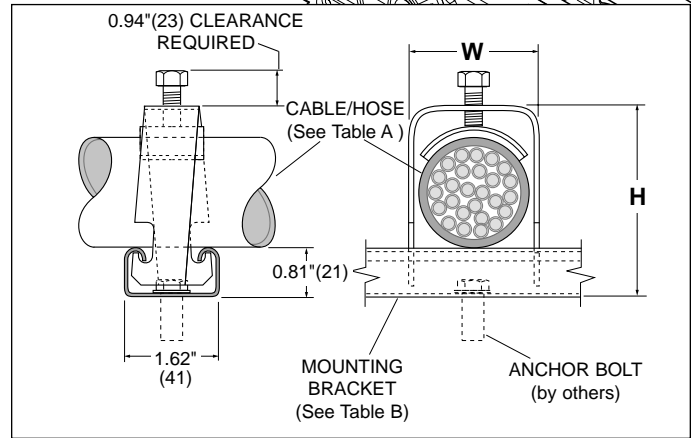
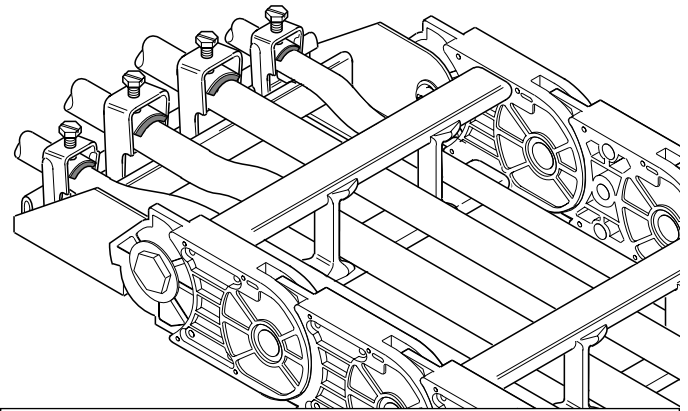

# Heavy Duty Cable/hose Tie Bracket

- Affixes hoses or cables at ends of trak to prevent undue wear or stress.
- Dual tie system holds more securely than single ties. Ties not included.
- Rugged baked polyester finished steel with zinc plated hardware.

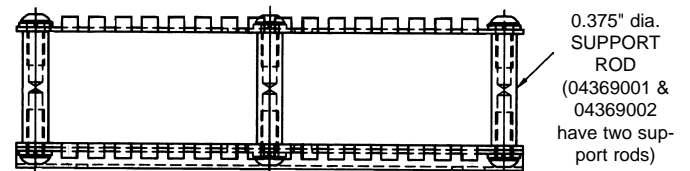
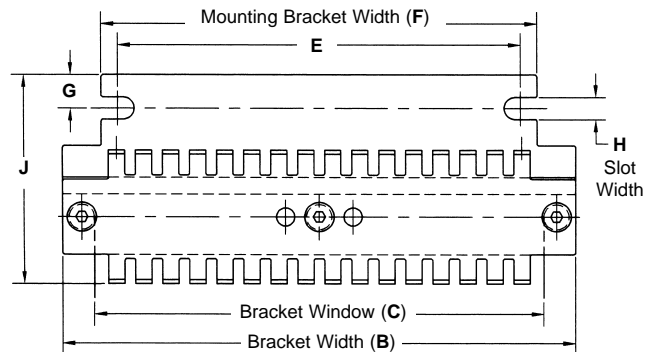
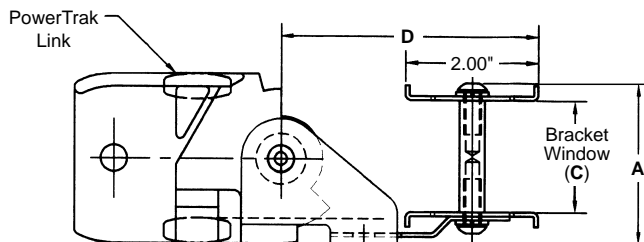
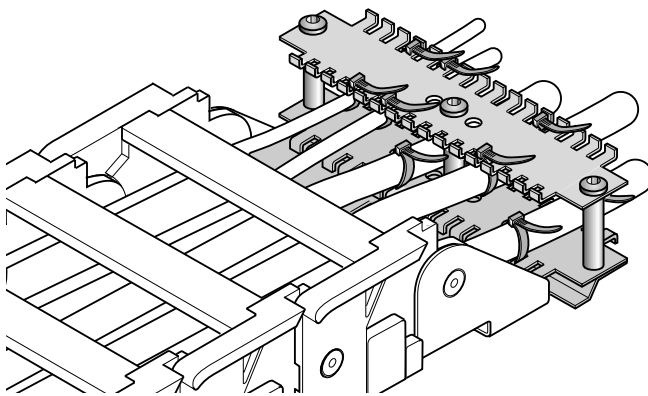

PART NO	CABLE/HOSE MAX. O.D.	A	B	C Ht. x Wd.	D	E	F	G	H	J
04369005	2.12	3.26	9.60	2.50 x 8.66	7.18	6.84 ± 0.68	7.96	0.88	0.438	3.81
04369004	1.46	2.40	7.20	1.65 x 6.26	6.18	5.08 ± 0.62	6.11	0.63	0.406	3.44
04369003	1.46	2.38	7.60	1.65 x 6.66	3.87	5.96 ± 0.16	6.45	0.50	0.344	3.15
04369002	1.46	2.38	5.20	1.65 x 4.26	3.87	3.62 ± 0.16	4.11	0.50	0.344	3.15
04369001	1.46	2.38	3.60	1.65 x 2.66	3.87	1.96 ± 0.16	2.45	0.50	0.344	3.15

All dimensions in inches.



PT-8

Gleason Reel Corp., 600 S. Clark St., Mayville, WI 53050 • 920-387-4120

# Ordering Type “E” PowerTrak

## BUILDING MODEL NUMBER

For specific information, please refer to pages 8–19 and the following pages.

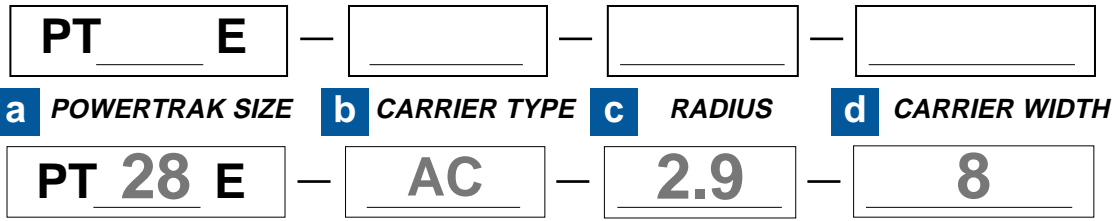

Bend radius shortened when used in model number. Example: 2.95 = 2.9

### a ENTER POWERTRAK SIZE

PowerTrak size should be suitable for the travel length required for your application and for the cable/hose package it is expected to carry. If it is not, you must choose another size or type PowerTrak. See pages 10–19 for specifications on each size PowerTrak. Use of a guide tray or guide tray & carriage, if available for a given size PowerTrak, can increase travel. See page 29 for help calculating travel in your application and page 28 for more information about defining your cable/hose “package”.

### c ENTER BEND “RADIUS”

Each PowerTrak size is available with several radii (pages 10–19 and Selection Guide, page 26). Radius chosen should be equal to or greater than the minimum bend radius of your LEAST FLEXIBLE cable or hose (page 28). If this condition is not met, you must choose a PowerTrak size with a larger bend radius. Consult your cable/hose supplier or manufacturer for specific information if you are not sure of the bending radius of each cable or hose to be used in the PowerTrak.

### b ENTER CARRIER TYPE

Carrier Type should be suitable for the cable/hose package (page 28), machine duty cycle and PowerTrak size chosen. Refer to Carrier Selection Guides, pages 8 & 9, and PowerTrak Specifications, pages 10–19.

### d ENTER CARRIER WIDTH

Carrier width should be cable/hose package width x 1.20 (refer to page 28) and be compatible with PowerTrak size chosen. See Pages 10–19 for carrier window dimensions and compatibility with each size trak.

## ADD THE FOLLOWING—Required, but not part of model number

### e POWERTRAK LENGTH (page 29)

**NOTE:** “Length to order” is computed differently if “two-way payout” is not possible. See “Applying PowerTrak” on the previous pages for details and consult a factory representative if necessary.

### f OPTIONAL ACCESSORIES

Mounting brackets **are not automatically included** and must be ordered here if required. Specify type of bracket. Refer to pages 10–19 and page 30. If roller supports or carriage are required and are available for the size PowerTrak you are ordering, also enter that information here. Carriage length will be calculated by factory.



**INFORMATION COMPLETE!**





## DETERMINING TRAK SIZE

Trak size must be carefully chosen to provide maximum life for both cable/hose package and trak. When selecting trak, pay close attention to the following:

A. Radius...trak must have bend radius **greater** than least flexible cable/hose bend radius. See [page 28](#) and [PowerTrak Selection Guide](#), page 26.

B. Total travel...be sure total travel required does not exceed specifications for chosen trak size. See graphs at right and [PowerTrak Selection Guide](#).

C. Carrier type...although carrier type and size may not have yet been chosen, consider width of total cable/hose package ([pages 27 & 28](#)), as well as diameter of largest cable or hose.

D. Choose trak that will allow use of a carrier of sufficient size to contain cable/hose. Refer to pages 10 – 19 for more information. With the above in mind, use graphs at right to select PowerTrak size. Draw horizontal line for weight (lbs/ft.) of cable package and vertical line for required total travel. Choose only PowerTrak sizes whose “curves” are above and to the right of the point at which these lines intersect. See example below. Refer to [PowerTrak Selection Guide](#).

### Sample Plot

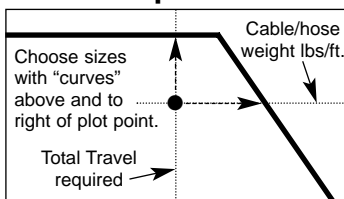

See  
**“CARRIAGE SYSTEMS”**  
 or ask for  
 more information on  
**“SUPER DUTY  
 POWERTRAK”**  
 if your needs exceed  
 the capabilities offered  
 in the graphs at right.

### PowerTrak Travel Capabilities-SELF SUPPORTED

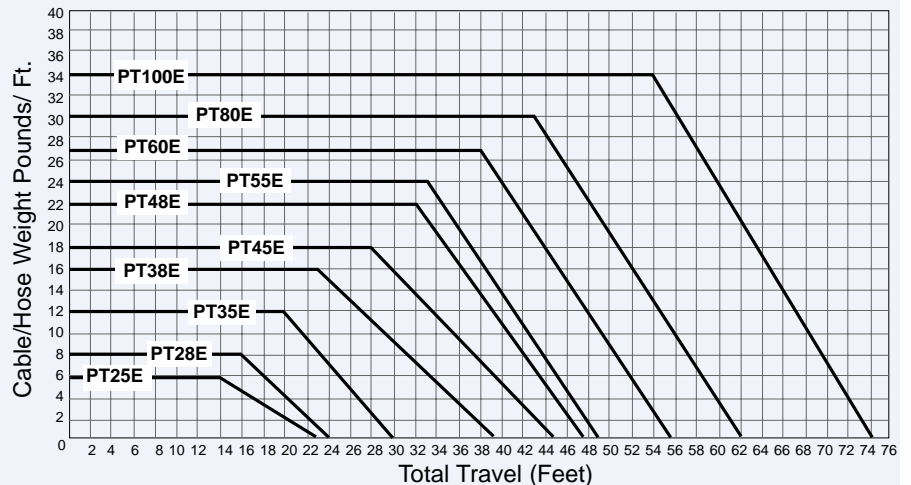

### PowerTrak Travel Capabilities-ONE ROLLER SUPPORT

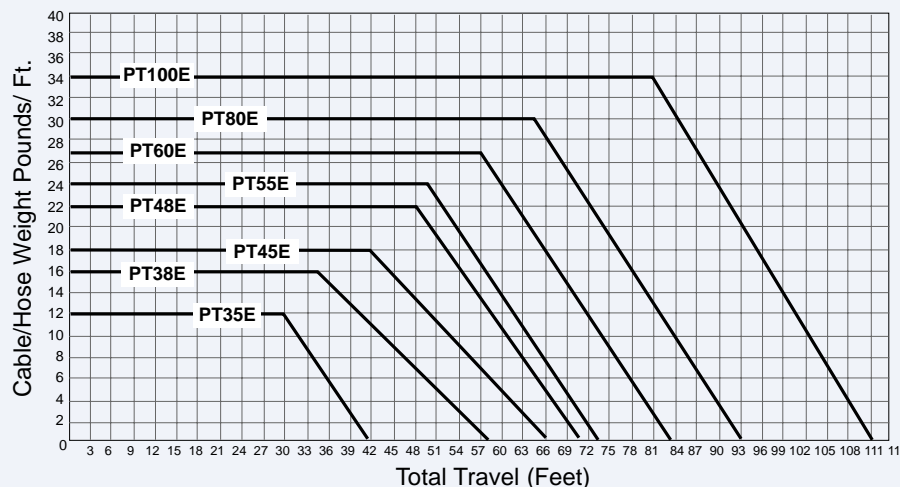

### PowerTrak Travel Capabilities-TWO ROLLER SUPPORTS

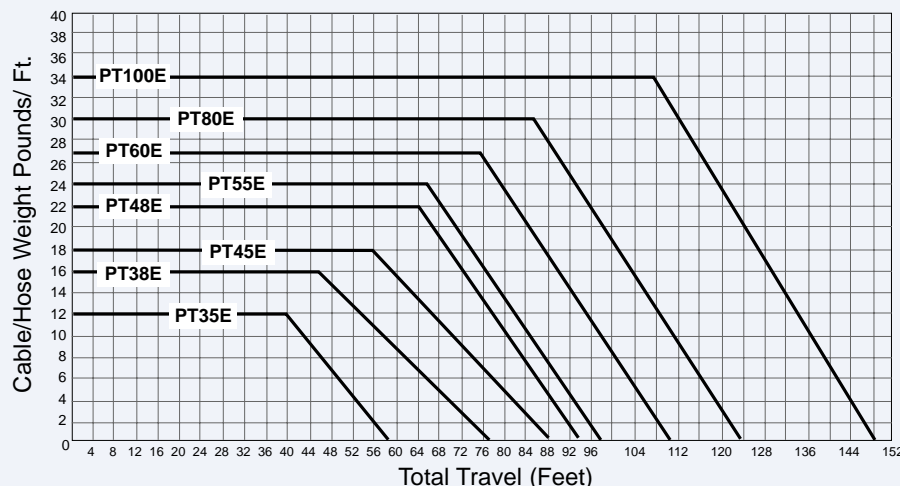

# Type "E" PowerTrak Selection Guide

POWERTRAK SIZE	CABLE/HOSE	CARRIER TYPE ③	POWERTRAK BEND RADII		CARRIER WIDTH		TOTAL TRAVEL (ft) ①			MAX SPEED (fpm)②	SEE PAGE NUMBER
	MAX O.D.		STANDARD	OPTIONAL	STANDARD	OPTIONAL	NO SUPPORT	ONE SUPPORT	TWO SUPPORTS		
	ALLOWED				"C"	WIDTHS					
PT25E	1.00	BC SR,R1 AC,A1,TB,T1 RN SS ⑧ RR ⑧	2.95, 5.16 8.00, 11.72	Unlimited ④ over 2.95	4, 6, 8, 10, 12	Unlimited ④ from 2.00–12.00	20	NA ⑤	NA ⑤	300	10
	0.78										
	0.87										
	0.62										
	1.11										
0.82											
PT28E	1.36	BC SR,R1 AC,A1,TB,T1 RN RR ⑧	2.95, 4.53 6.10	Unlimited ④ over 2.95	4, 6, 8, 10, 12	Unlimited ④ from 2.00–12.00	22	NA ⑤	NA ⑤	300	11
	1.04										
	1.09										
	0.88										
	1.07										
PT35E	1.81	BC SR,R1 AC,A1,TB,T1 RN SS ⑧ RR ⑧ RB, RB1 TRB, TR1	5.22, 7.50 11.12, 15.00 24.31	Unlimited ④ over 5.22	4, 6, 8, 10, 12, 14, 16	Unlimited ④ from 4.00–18.00	28	42 ⑥	56 ⑥	400	12
	1.29										
	1.39										
	1.19										
	1.92										
	1.34										
	1.03										
1.03											
PT38E	2.28	BC SR,R1 AC,A1 RN RR ⑧	3.5, 5.00 6.00, 7.88 11.38, 15.38	Unlimited ④ over 3.5	4, 6, 8, 10, 12, 14, 16	Unlimited ④ from 4.00–18.00	37	55 ⑥	74 ⑥	400	13
	1.62										
	1.67										
	1.51										
	1.64										
PT45E	2.73	BC SR,R1 AC,A1,TB,T1 RN RR ⑧ RB, RB1 TRB, TR1	5.71, 7.50 11.22, 15.00 24.31	Unlimited ④ over 5.71	4, 6, 8, 10, 12, 14, 16	Unlimited ④ from 4.00–24.00	43	64 ⑥	86 ⑥	500	14
	2.12										
	2.25										
	2.02										
	2.19										
	1.88										
	1.88										
PT48E	3.41	BC SR,R1 AC,A1 RN RR ⑧	5.75, 7.50 11.25, 15.00 24.25	Unlimited ④ over 5.75	4, 6, 8, 10, 12, 14, 16	Unlimited ④ from 4.00–24.00	46	69 ⑥	92 ⑥	500	15
	2.87										
	2.92										
	2.76										
	2.89										
PT55E & PT55EF	4.10	BC WC WV WH HN HV NV	11.22, 15.00 18.69, 24.31 30.00, 36.00	Unlimited ④ over 11.22	6, 8, 10, 12, 14, 16, 18, 20, 22, 24	Unlimited ④ from 6.00–24.00	48	72	96 ⑦	500	16
	3.12										
	3.12										
	1.36										
	1.30										
	1.36										
1.30											
PT60E & PT60EF	4.55	BC WC WV WH HN HV NV	11.00, 14.81 20.50, 24.12 29.50	Unlimited ④ over 11.00	6, 8, 10, 12, 14, 16, 18, 20, 22, 24	Unlimited ④ from 6.00–24.00	54	81 ⑦	108 ⑦	500	17
	3.54										
	3.54										
	1.57										
	1.51										
	1.57										
1.51											
PT80E & PT80EF	5.91	BC WC WV WH HN HV NV	10.50, 12.50 19.50, 23.012	Unlimited ④ over 10.50	8, 10, 12, 14, 16, 18, 20, 22, 24	Unlimited ④ from 8.00–24.00	61	92 ⑦	122 ⑦	500	18
	5.00										
	5.00										
	2.19										
	2.13										
	2.19										
2.13											
PT100E & PT100EF	7.73	BC WC WV WH HN HV NV	19.00 25.00	Unlimited ④ over 19.00	10, 12 14, 16, 18, 20, 22, 24	Unlimited ④ from 10.00–24.00	73	110 ⑦	146 ⑦	500	19
	6.66										
	6.66										
	3.02										
	2.97										
	3.02										
2.97											

① Total Travel values based upon standard travel (two-way payout) and total cable/hose weight of 2.00 lbs/ft. See this weight applied in Travel Capabilities tables, page 25.

② Speed capabilities may increase for shorter machine travels and/or light loads. Please consult factory.

③ See pages 8–9 for details on Carrier types.

④ Please consult the factory concerning non-standard Bend Radii and non-standard Carrier Widths

⑤ Roller supports not recommended for Types PT25E and PT28E.

⑥ For Standard Duty Total Travel greater than 50 ft., please consult the factory.

⑦ For Heavy Duty and Mill Duty Total Travels greater than 80 ft., please consult the factory.

⑧ Carrier width limited to 10" (max).

# Ordering (continued)



## DETERMINING CARRIER

Refer to Carrier Options, pages 8 & 9, and Trak specifications, pages 10–19. Use the following criteria when selecting a carrier type and width:

- A. Cable/hose package (**JQsum** and **PKG HEIGHT** from calculations, page 28). Multiply each by 1.20 to find minimum carrier length and height that should be used for your application. See Figure 1, right.
- B. CARRIER OPTIONS, pages 8 & 9, for benefits of each style carrier.  
**NOTE: Style BC is most efficient design from an operational standpoint but not necessarily from a capacity standpoint. Do a careful layout. Follow instructions below.**

FIG. 1 PowerTrak Cross Section

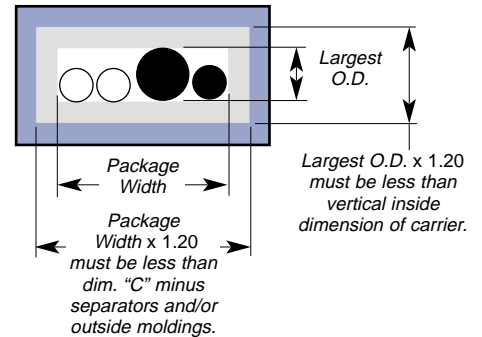

Select carrier style and size. **Selected carrier must fit PowerTrak size chosen.** If it does not, select alternate carrier or go back and select next largest PowerTrak size.

### Special Instructions for Type BC Carrier

Type BC carrier uses a "split" machined aluminum bar which supports the cables/hoses near the true bending radius of the trak. Holes are custom machined to meet the particular application. When designing the hole layout, pay attention to the following:

1. Cables/hoses must be positioned to form a single layer with weight evenly distributed across width of carrier. If there are two or more such cables/hoses, the heaviest and largest should be located near the PowerTrak links (to outside). If there is only one heavy cable/hose, locate it in the center to evenly distribute the weight.
2. Determine clearance for each cable or hose as follows:
  - A. For nominal O.D.'s greater than 1.25", multiply O.D. by 1.1
  - B. For nominal O.D.'s equal to or less than 1.25", add 0.12"
3. Maintain a 0.25" space between holes to facilitate machining. If this is not possible, use a wider carrier or group two or three cables/hoses together in one horizontal slot (Fig 2).
4. Hoses operating at pressure greater than 200 psi should be individually contained in a vertical slot (Fig. 2).

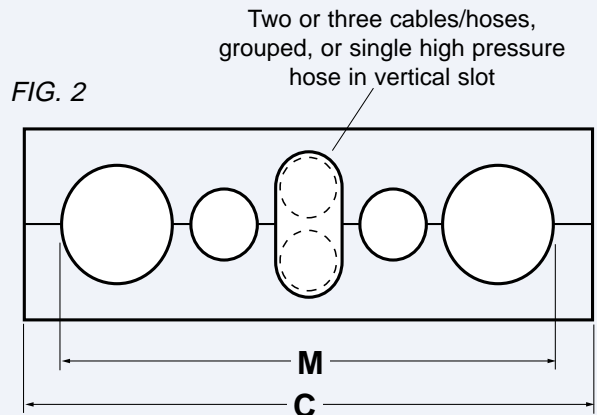

To determine carrier width (C), calculate machining pattern (M) which is sum of hole diameters and spaces between holes plus 0.75" for PT25E thru PT48E and 1.00" for PT55E thru PT100E. Round this factor UP to nearest multiple of 2.

**EXAMPLE:** Sum of all holes ..... 8.75"  
 Sum of spaces between holes ..... 1.00"  
 Trak chosen is PT35E. Add ..... 0.75" (1.00" on larger sizes. See above. Provides minimum 0.35" or 0.50" on each end of carrier.)  
 (M) = 10.50"  
 Round up to nearest 2" ..... (C) = 12.00" (Standard widths in 2" increments.)

**NOTE: Please include sketch of machining pattern with your order. Consult factory for special width requirements.**



## DEFINING YOUR CABLE/HOSE "PACKAGE"

IF YOU WISH, MAKE COPIES OF THIS PAGE FOR WORKING OR FAXING

Picture your cables and hoses as a GROUP, what we call a cable/hose "PACKAGE."

- PowerTrak should **NOT** have a radius less than the minimum bending radius of the least flexible cable or hose in your package, *usually* the recommended minimum bend radius of the largest cable or hose in your package (Fig 1).
- Package must fit into a PowerTrak WINDOW. Allow for at least 20% clearance. See Fig. 2 and refer to pages 10-19.

**IMPORTANT: Information about your cables and hoses is CRITICAL for selecting the correct PowerTrak.**

FIG. 1 Cable/Hose Bend Radius

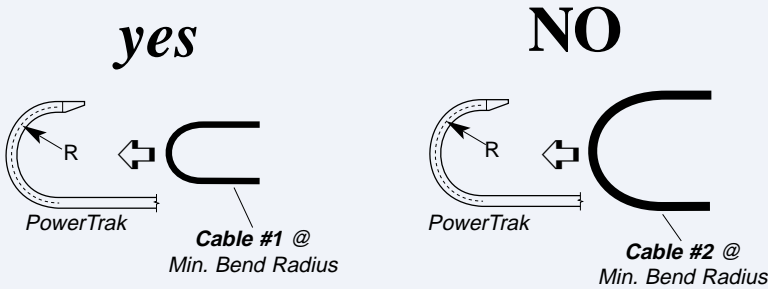

*PowerTrak must have a large enough radius.*

FIG. 2 PowerTrak Cross Section

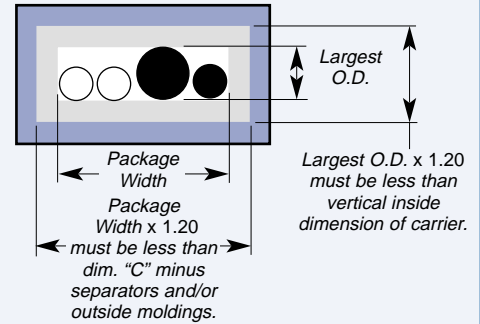

*Your package must fit a window.*

Fill in all of the blanks in the Worksheet below (if necessary, refer to "Cable & Hose Data" at the back of this catalog for diameters and weights of typical cables and hoses).

Cable/Hose Descrip. (Include Qty of each @ right)	J O.D.	D Min. Bend*	A Lbs/Ft	Q Quantity	AQ (A x Q)	JQ (J x Q)
_____	_____	_____	_____	_____	_____	_____
_____	_____	_____	_____	_____	_____	_____
_____	_____	_____	_____	_____	_____	_____
_____	_____	_____	_____	_____	_____	_____
_____	_____	_____	_____	_____	_____	_____
_____	_____	_____	_____	_____	_____	_____
_____	_____	_____	_____	_____	_____	_____
_____	_____	_____	_____	_____	_____	_____
_____	_____	_____	_____	_____	_____	_____
_____	_____	_____	_____	_____	_____	_____

TOTAL NO. OF CABLES/HOSES (for machined bar carrier option) → **QSUM =** \_\_\_\_\_

TOTAL CABLE/ HOSE WEIGHT → **AQSUM =** \_\_\_\_\_ Lbs/ft

PKG WIDTH (Total of all O.D.s) → **JQSUM =** \_\_\_\_\_ In

PKG HEIGHT (Largest O.D. [J] of all) \_\_\_\_\_ Inches

PKG MINIMUM BEND RADIUS\* \_\_\_\_\_ Inches

\*PKG MINIMUM BEND RADIUS: Your package should only bend as tight as the LARGEST recommended min. bend radius of all cables or hoses in your package. Generally, but not always, the minimum bend radius is largest on your LARGEST O.D. cable/hose. Bend radius information should be available from the cable/hose manufacturer. If no information is available, a good method for determining min. bend radius of your package is to multiply your LARGEST O.D. by a factor of 6 (six): [6 x O.D.].







## DETERMINING LENGTH

You need enough PowerTrak to cover:

- The Total Travel (TT) of your machine, for one-way payout (Fig 1), or 1/2 the Total Travel, for two-way payout (fig 2).
- Plus the length to form the PowerTrak curve (L) from Dimension Tables, pages 10–19 (fig 3).

The most cost-effective way to use PowerTrak is to locate the trak's fixed end (cable/hose source) at the CENTER of the machine travel, allowing pay-out in two (2) directions. We refer to this as "Two-way payout", illustrated in figure 4. Travel potential for the same length PowerTrak is DOUBLED when two-way payout is used. In the same way, you minimize the cost of cables and hoses – they need be only about HALF as long as your total travel (TT).

Opposed Travel application (Fig 4) does not shorten the length of PowerTrak required on each side (both must be 1/2 total travel). Rather, an Opposed Travel application is two similar PowerTraks installed in opposite directions. This application may allow use of a smaller trak style, shorter carriers or a single-wide rather than double-wide trak configuration.

See Pages 10–19 for "L" (curve lengths) of various PowerTrak styles.

<b>ONE-WAY PAYOUT</b>	<b>TT (ft.) + L (ft.)</b>	<b>Length to order:</b>	<b>TWO-WAY PAYOUT</b>	<b><math>\frac{TT (ft.)}{2} + L (ft.)</math></b>
---------------------------	---------------------------	---------------------------------	---------------------------	--

**FIG. 1** STANDARD travel with ONE-WAY payout

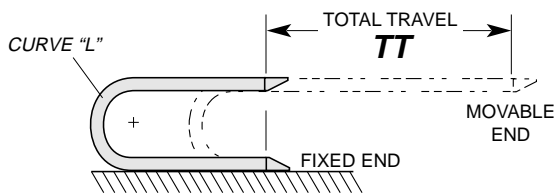

**FIG. 2** STANDARD travel with TWO-WAY payout

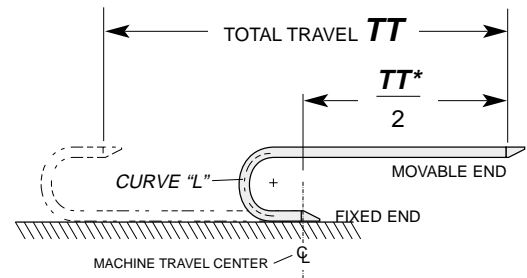

**FIG. 3**

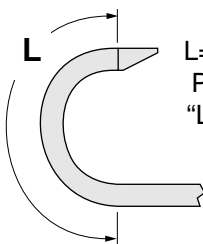

L = Minimum length to form PowerTrak curve. Obtain "L" from Dimension Tables on pages 10–19.

On OPPOSED TRAVEL applications, length of track **must be identical** for both PowerTraks. Style of carrier, including number of dividers, may differ between the two PowerTraks so as to accommodate different cable and hose arrangements. For long travels, use of a GUIDE TRAY is highly recommended. Use of a CARRIAGE is also recommended but not essential. If GUIDE TRAY is used, trak link style and carrier lengths must also be identical for the two PowerTraks.

**FIG. 4**

**OPPOSED travel with TWO-WAY payout**

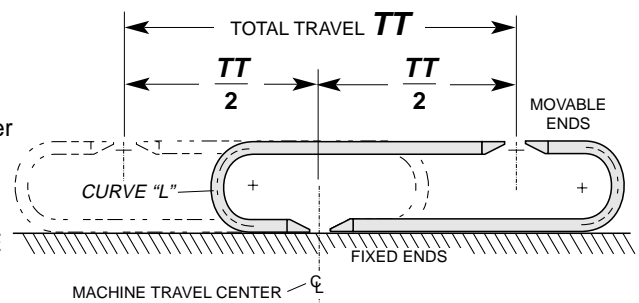

# Weight Calculations

Workspace for calculating PowerTrak® total assembly weight is provided below. Make copies if you wish. Weights for your specified cable/hose should be available from the manufacturer. Typical examples are listed on the facing page.

**POWERTRAK TOTAL ASSEMBLY WEIGHT** = (PowerTrak Weight/ft. + Total Cable/hose Weight/ft.) x PowerTrak Length

$$\text{PowerTrak Ass'y Wgt.} = \left( \text{PowerTrak Weight/ft.} + \text{Total Cable/hose Weight/ft} \right) \times \text{PowerTrak Length}$$

## PowerTrak Weights

### STANDARD DUTY (EMPTY)

SIZE	POUNDS PER FOOT
25E	2.32 + (C x 0.09)
28E	2.76 + (C x 0.11)
35E	4.36 + (C x 0.13)
38E	7.30 + (C x 0.14)
45E	9.36 + (C x 0.14)
48E	13.42 + (C x 0.15)

**NOTE:** Carrier weights among Standard Duty Carrier sizes is very similar. Therefore, NOMINAL carrier weights are used.

C = Carrier Width  
Y = No. of Vertical Separators

### HEAVY & MILL DUTY (EMPTY)

SIZE	CARRIER	POUNDS PER FOOT
55E & EF	BC	18.00 + (C x 0.19)
	WC	18.18 + (C x 0.30)
	WH	18.23 + (C x 0.34)
	HN	18.23 + (C x 0.34)
	WV(Y)	18.18 + (C x 0.30) + (Y x 0.18)
	HV(Y)	18.23 + (C x 0.34) + (Y x 0.18)
60E & EF	NV(Y)	18.23 + (C x 0.34) + (Y x 0.18)
	BC	21.04 + (C x 0.24)
	WC	21.24 + (C x 0.35)
	WH	21.30 + (C x 0.40)
	HN	21.30 + (C x 0.40)
	WV(Y)	21.24 + (C x 0.35) + (Y x 0.24)
80E & EF	HV(Y)	21.30 + (C x 0.40) + (Y x 0.24)
	NV(Y)	21.30 + (C x 0.40) + (Y x 0.24)
	BC	27.57 + (C x 0.29)
	WC	27.92 + (C x 0.33)
	WH	28.00 + (C x 0.42)
	HN	28.00 + (C x 0.42)
100E & EF	WV(Y)	27.92 + (C x 0.33) + (Y x 0.38)
	HV(Y)	28.00 + (C x 0.42) + (Y x 0.38)
	NV(Y)	28.00 + (C x 0.42) + (Y x 0.38)
	BC	33.78 + (C x 0.26)
	WC	33.96 + (C x 0.27)
	WH	34.03 + (C x 0.34)
100E & EF	HN	34.03 + (C x 0.34)
	WV(Y)	33.96 + (C x 0.27) + (Y x 0.41)
	HV(Y)	34.03 + (C x 0.34) + (Y x 0.41)
	NV(Y)	34.03 + (C x 0.34) + (Y x 0.41)

## Mounting Bracket Arrangements

• Even though they are usually required, **mounting brackets are not automatically included** and must be itemized on the order.

• Unless otherwise specified, trak will be manufactured with bracket flanges pointing “in”. Please indicate if flanges must face “out”.

• Arrangement 1 (see drawing at right) will be used on the moving end on all models. If an even number of links is required on models PT25E through PT48E, the fixed end brackets will be mounted using arrangement 2. Arrangement 1 is used on both ends of larger tracks. As an aid to preparing detailed drawings, use the following procedure and refer to Pages 10–19 for mounting bolt location.

1. Convert PowerTrak Length (from previous page) to inches.
2. Determine number of links using the formula:  
Number of Links = PowerTrak Length (inches) ÷ Link Pitch.  
Round UP. (Link pitch found on pages 10–19).

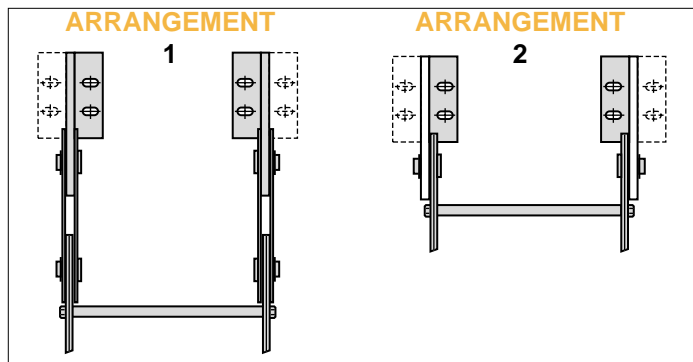

3. If the result is an ODD number of links, mounting brackets on both ends will be installed using ARRANGEMENT 1.

If the result is an EVEN number of links, the “fixed” or stationary end of your PowerTrak will receive ARRANGEMENT 2. The “moving end” will receive ARRANGEMENT 1.

# Cable & Hose Data

## TYPE SO CABLE — 600 VOLT

16 AWG			14 AWG			12 AWG			10 AWG		
No. Cond.	Dia. In.	Weight lb/ft	No. Cond.	Dia. In.	Weight lb/ft	No. Cond.	Dia. In.	Weight lb/ft	No. Cond.	Dia. In.	Weight lb/ft
2	0.374	0.094	2	0.512	0.158	2	0.586	0.204	2	0.638	0.250
3	0.393	0.110	3	0.538	0.184	3	0.616	0.244	3	0.671	0.310
4	0.427	0.144	4	0.584	0.224	4	0.668	0.282	4	0.730	0.371
5	0.510	0.156	5	0.665	0.260	5	0.725	0.322	5	0.796	0.425
6	0.565	0.178	6	0.710	0.302	6	0.805	0.380	6	0.883	0.485
7	0.605	0.202	7	0.710	0.329	7	0.865	0.435	7	0.982	0.593
8	0.645	0.222	8	0.770	0.373	8	0.920	0.475	9	1.127	0.725
9	0.720	0.268	9	0.820	0.414	9	1.020	0.550	10	1.127	0.760
10	0.720	0.278	10	0.885	0.434	10	1.020	0.581	12	1.153	0.850
12	0.740	0.305	12	0.905	0.481	12	1.050	0.645	20	1.455	1.400
14	0.775	0.348	14	1.000	0.556	14	1.105	0.743	24	1.595	1.645
16	0.825	0.386	16	1.050	0.657	16	1.160	0.840	26	1.595	1.740
18	0.860	0.430	18	1.110	0.715	18	1.227	0.925	28	1.725	1.880
20	0.900	0.466	20	1.150	0.785	20	1.287	1.005	32	1.830	2.180
22	0.940	0.503	22	1.210	0.857	22	1.370	1.140	36	1.890	2.400
24	1.015	0.564	24	1.320	0.920	24	1.443	1.225	40	2.030	2.660
26	1.015	0.604	26	1.350	0.986	26	1.443	1.290	44	2.115	2.890
28	1.070	0.654	28	1.370	1.098	28	1.523	1.400	48	2.150	3.100
30	1.070	0.677	30	1.390	1.138	30	1.523	1.450	52	2.200	3.330
32	1.120	0.714	32	1.450	1.220	40	1.820	1.990	56	2.275	3.550
34	1.155	0.807	34	1.495	1.300	44	1.900	2.140			
36	1.155	0.820	36	1.515	1.359	48	1.930	2.300			
40	1.235	0.881	40	1.550	1.429	52	1.980	2.450			
44	1.280	0.940	44	1.715	1.619	56	2.020	2.600			
48	1.290	0.995	48	1.740	1.734	60	2.090	2.780			
52	1.360	1.100	52	1.784	1.843						
56	1.410	1.170	56	1.865	2.030						
60	1.465	1.260	60	1.925	2.156						

## TYPE W CABLE — 600 VOLT

AWG Size	No. Cond.	Dia. In.	Weight lb/ft
8	2	0.788	0.328
	3	0.894	0.470
	4	0.966	0.583
6	2	0.872	0.425
	3	0.983	0.614
	4	1.068	0.769
4	2	1.040	0.780
	3	1.068	0.797
	4	1.166	1.019
3	2	1.033	0.687
	3	1.135	0.950
	4	1.241	1.197
2	2	1.177	0.888
	3	1.244	1.152
	4	1.326	1.429
1	2	1.365	1.090
	3	1.413	1.491
	4	1.548	1.877
1/0	2	1.454	1.386
	3	1.539	1.805
	4	1.686	2.309
2/0	2	1.555	1.640
	3	1.647	2.154
	4	1.807	2.738

## TYPE G-GC CABLE — 600 VOLT

AWG Size	No. Cond.	Dia. In.	Weight lb/ft
8	3	0.915	0.661
6	3	1.000	0.792
4	3	1.120	1.088
3	3	1.180	1.250
2	3	1.250	1.436
1	3	1.440	1.856
1/0	3	1.565	2.270
2/0	3	1.630	2.660

Refer to the National Electric Code for ampere ratings and other details.

### HOSE GENERAL PURPOSE

Listings for general purpose hose do NOT include fluid weight. Specific fluid weights should be added when figuring Total Cable/Hose Weight.

I.D. In.	Braid	O.D. In.	PSI (WORKING)	Weight lb/ft
.25	2	0.59	250	0.13
.38	2	0.72	250	0.18
.50	2	0.84	250	0.23
.75	2	1.16	250	0.37
1.00	2	1.50	150	0.64
1.25	2	1.75	150	1.01
1.50	2	2.00	150	1.06

### HOSE SINGLE HYDRAULIC

Listings for single hydraulic hose do NOT include fluid weight. Specific fluid weights should be added when figuring Total Cable/Hose Weight.

I.D. In.	Braid	O.D. In.	PSI (WORKING)	Weight lb/ft
.25	2	0.58	5000	0.23
.38	2	0.73	4000	0.35
.50	2	0.86	3500	0.42
.75	2	1.14	2250	0.60
1.00	2	1.48	2000	0.89
1.25	2	1.87	1625	1.40

Whenever possible, refer to specific manufacturer's information regarding cable or hose. If this information is not available, these charts are composites and may be used as guides to typical cable and hose size and weights.

# Cable Management

Since 1911 Gleason Reel Corp. has been in the business of CABLE MANAGEMENT. Our products are designed to convey and protect valuable cables and hoses that power and control moving machines of all types. They improve productivity and safety on the job by moving cables and hoses away from hazardous locations on machinery or the shop floor into a controlled environment. Whether you choose Reels for efficient storage and payout from virtually any angle, Festoon Systems for overhead applications or PowerTrak® for protection on machinery in motion, your cables and/or hoses will last longer and provide better service with a cable management system from **Gleason Reel Corp. ...**

***...The Cable & Hose Management Company!***



**In addition to three types of PowerTrak, one of which is detailed in this catalog, Gleason manufactures a complete line of motor or spring driven and hand operated cable and hose reels in a wide variety of sizes as well as I-beam, c-rail and wire rope supported festoon systems for handling cables or hoses overhead. Contact Gleason Reel Corp. or your local Gleason Representative.**



## **Gleason Reel Corp.**

P.O. Box 26 • 600 South Clark St.  
Mayville, Wisconsin 53050-0026  
Phone 920-387-4120 • FAX 920-387-4189  
[www.hubbell-gleason.com](http://www.hubbell-gleason.com)